

Stuttgarter AktienBrief

WIR LEBEN BÖRSE – SEIT 1984 !!

**Herzlich willkommen
zur Börsen-Veranstaltung
in Stuttgart**



40 Jahre Jubiläumstour

Stuttgarter AktienBrief

WIR LEBEN BÖRSE – SEIT 1984 !!

**Herzlich willkommen
zur Börsen-Veranstaltung
in Stuttgart**





COLLEGIUM WIRTEMBERG

Rotenberg & Uhlbach





Patrick Brun

5 Wachstumsaktien im Brennpunkt



**Patrick
Brun**



Christoph Wendling

Die Überlegenheit der Aktie

Was bei der Dividende wirklich wichtig ist



**Patrick
Brun**



**Christoph
Wendling**



Dieter Beck

Jeder Tag ist Kauftag!



**Patrick
Brun**



**Christoph
Wendling**



**Dieter
Beck**



Joachim Brandmaier



Patrick Brun

5 Wachstumsaktien im Brennpunkt

Die Top 5

der meistgefragten
Aktien unserer Leser



Platz	Anfragen	Aktientitel
1	3.245	?
2	2.387	?
3	1.637	?
4	1.346	?
5	896	?

Die Top 5

der meistgefragten
Aktien unserer Leser



Platz	Anfragen	Aktientitel
1	3.245	?
2	2.387	?
3	1.637	?
4	1.346	?
5	896	?

Die Top 5

der meistgefragten
Aktien unserer Leser



Platz	Anfragen	Aktientitel
1	3.245	?
2	2.387	?
3	1.637	?
4	1.346	?
5	896	Starbucks

USD

STARBUCKS

115

100

90

70

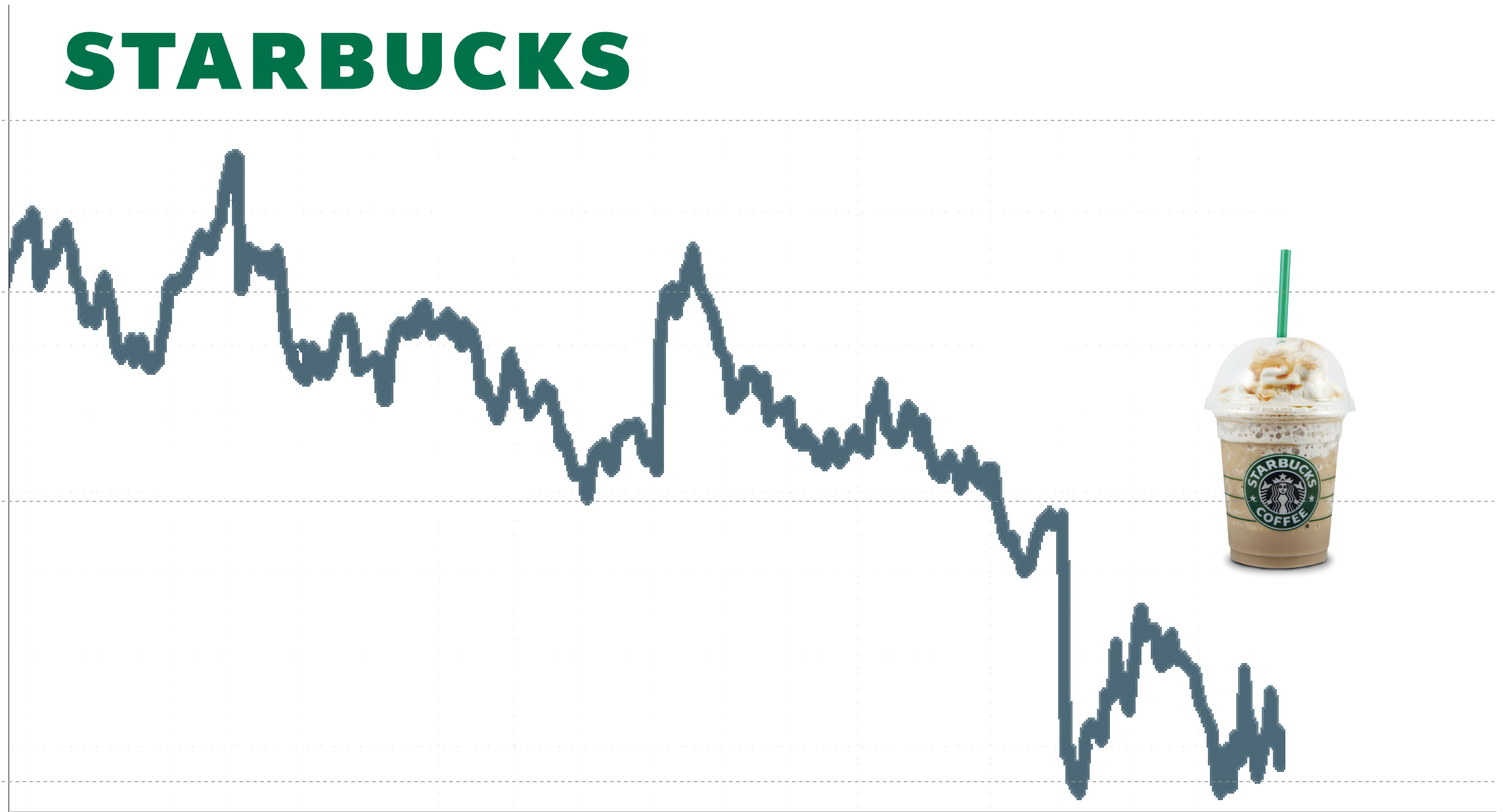

STARBUCKS

USD

115

100

90

70

2023

2024

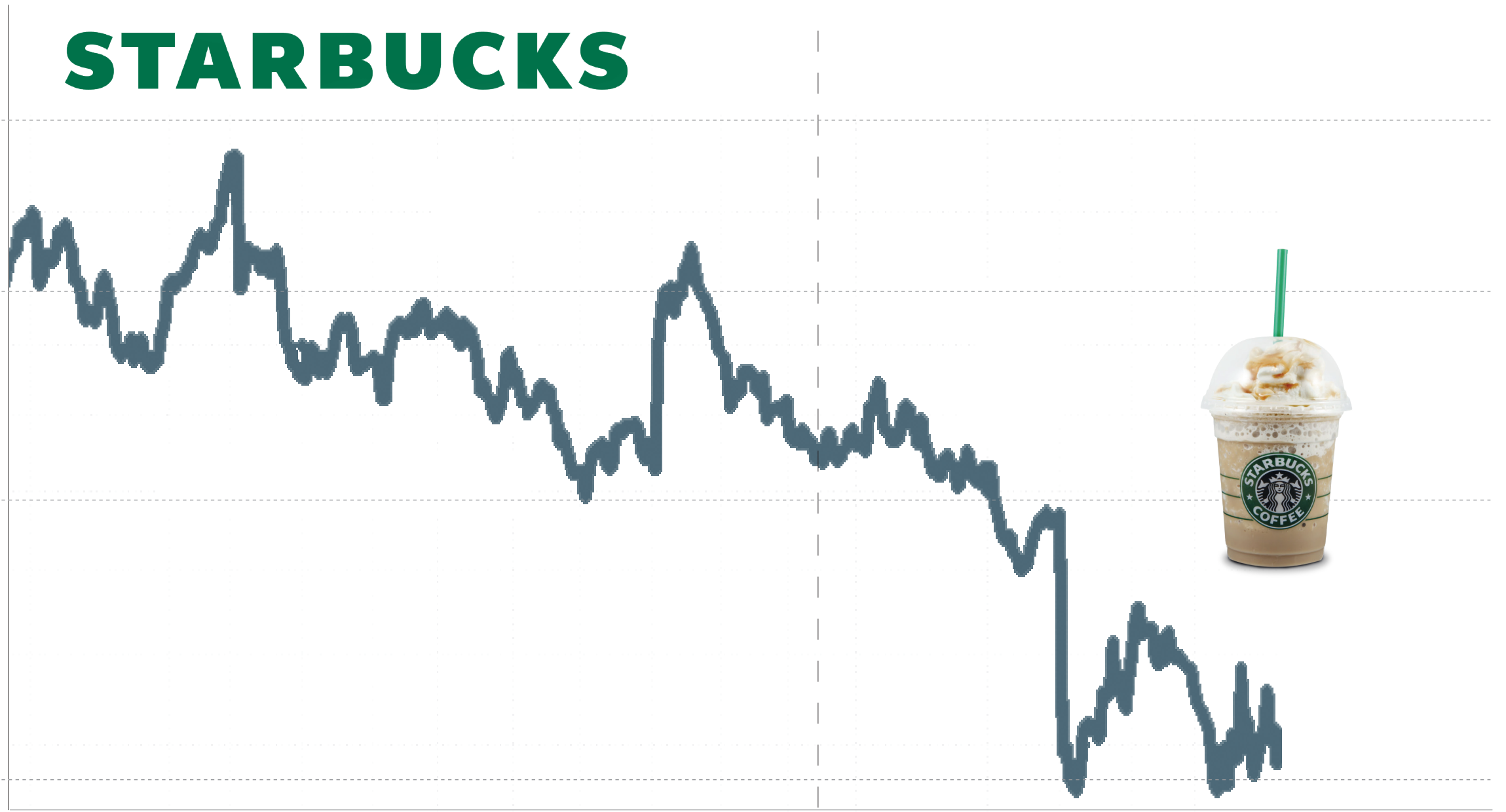

USD

STARBUCKS®

115

100

90

70

2023

2024

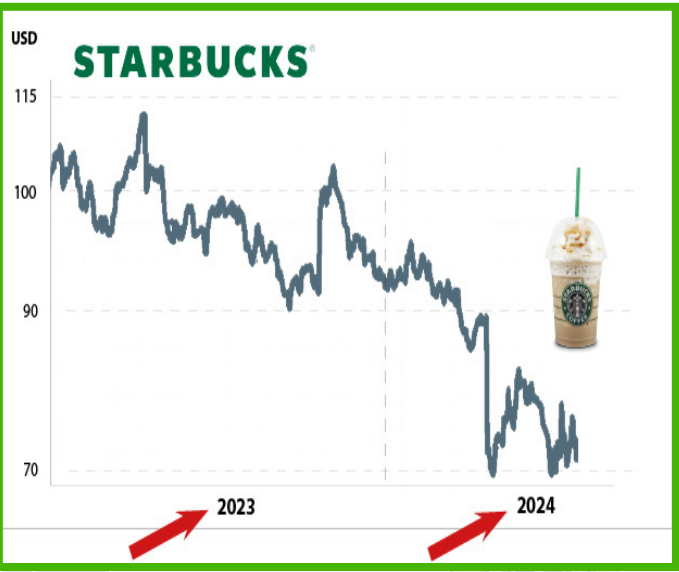

USD

STARBUCKS®



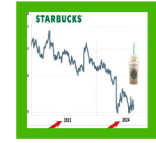

STARBUCKS

USD

115

30

5

1

92

94

96

98

00

02

04

06

08

10

12

14

16

18

20

22

24

26

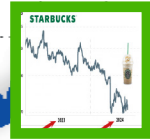

Bloomberg

STARBUCKS



Anzahl der Starbucks-Coffeeshops weltweit

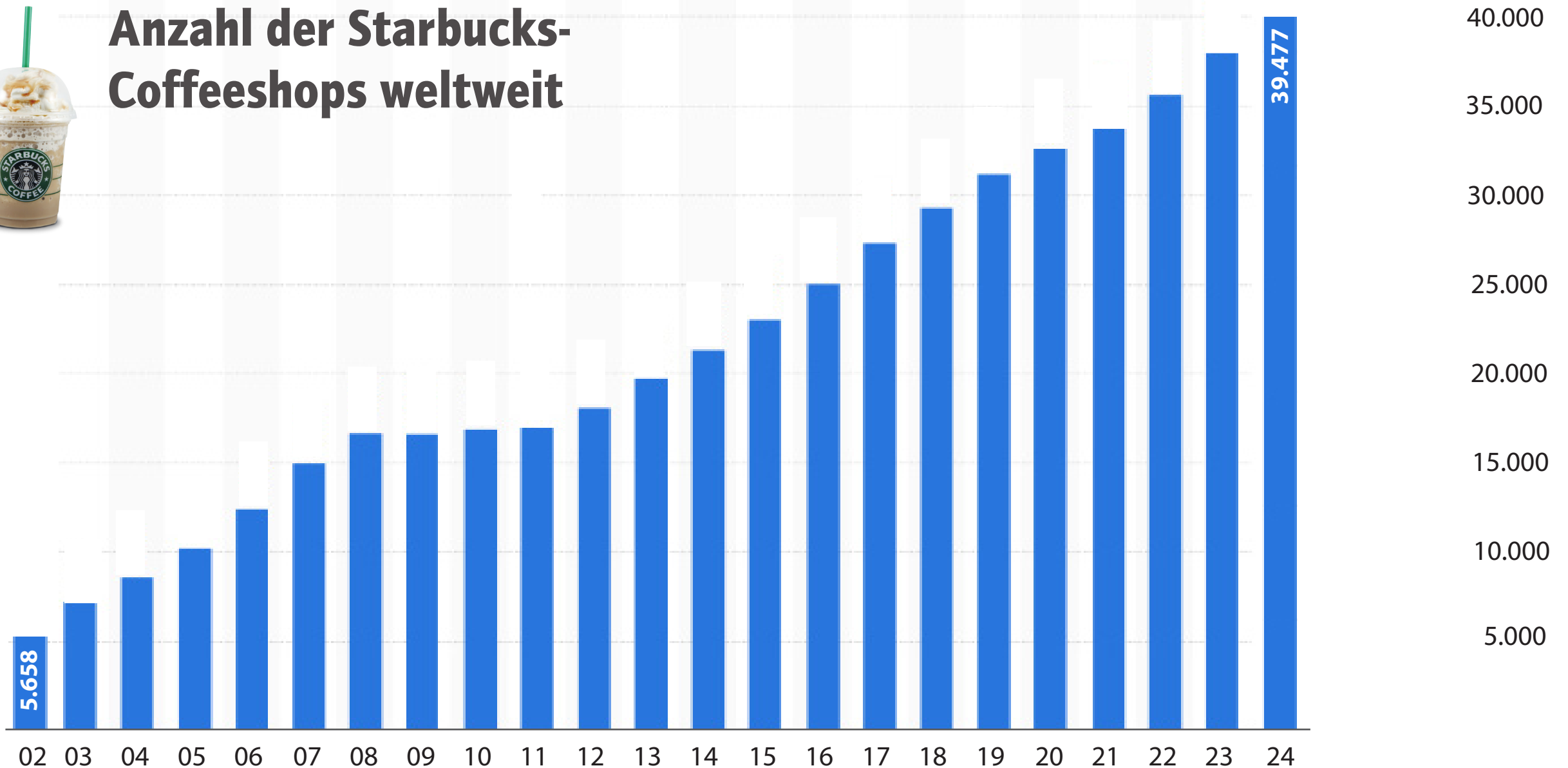

STARBUCKS



Anzahl der Starbucks-Coffeeshops weltweit

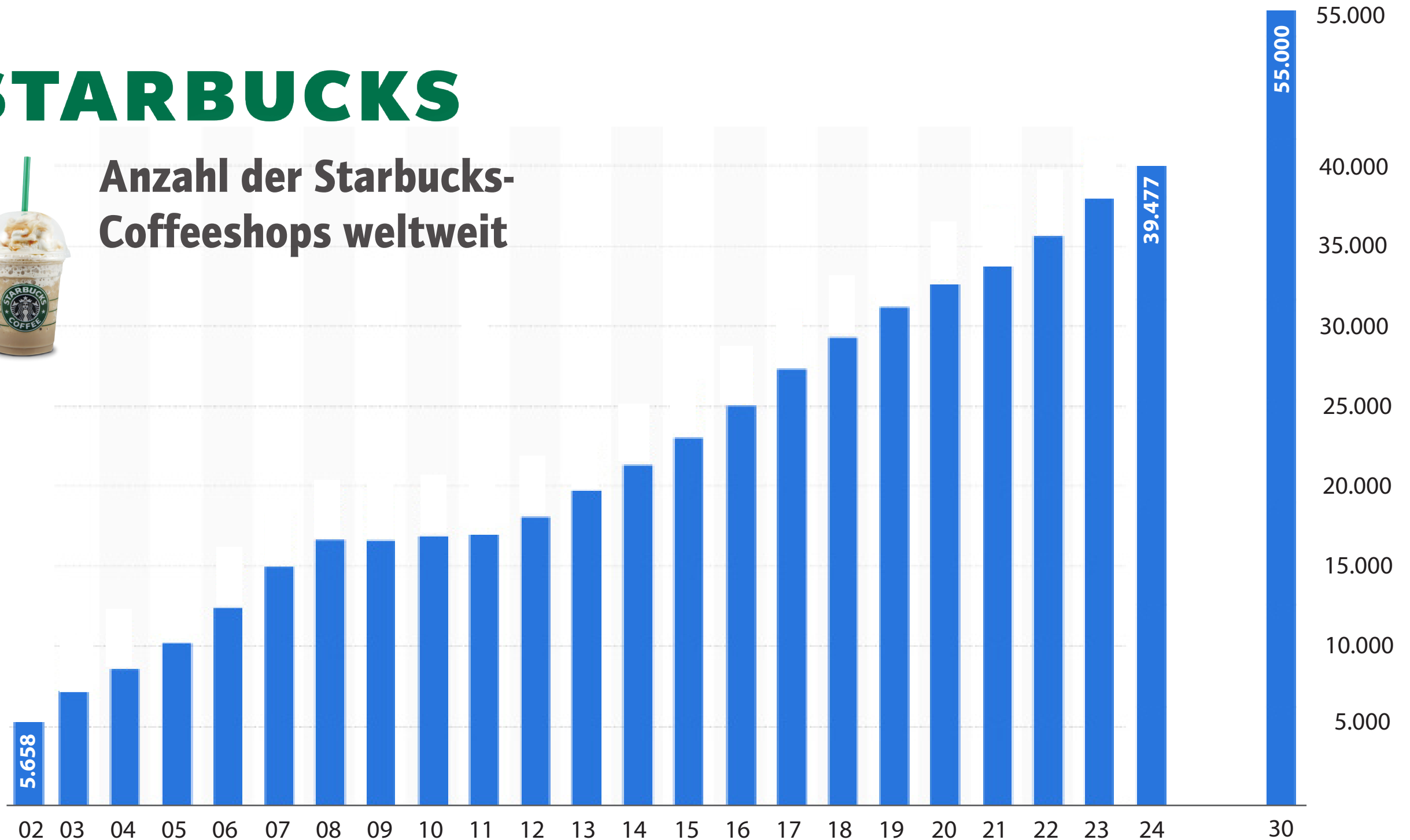

STARBUCKS



Erstes Starbucks in
Deutschland im Jahr 2002:

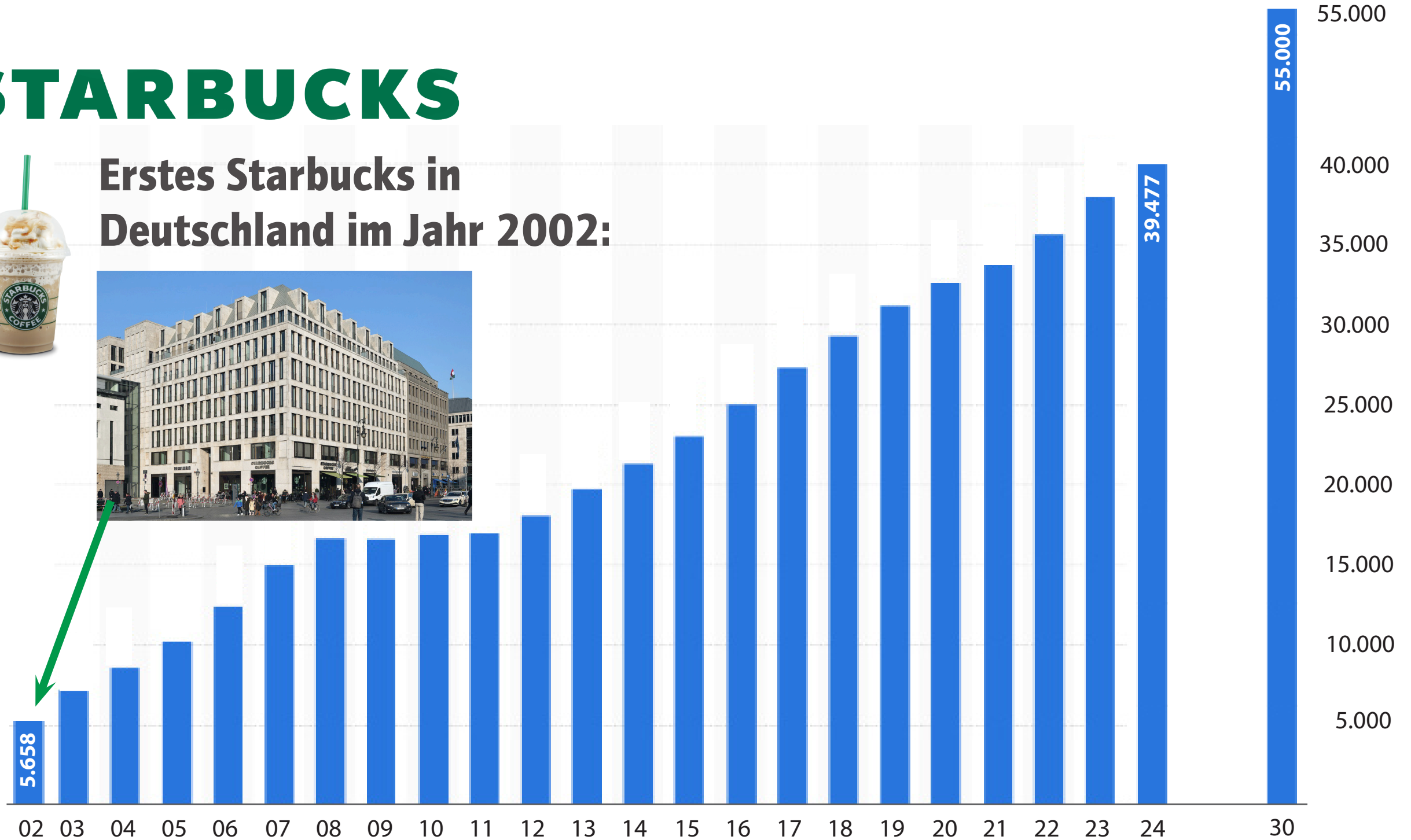

1. Starbucks in Deutschland: am Pariser Platz in Berlin



Research vor Ort – wir waren 2002 zu Besuch!

STARBUCKS

USD

115

30

5

1

92

94

96

98

00

02

04

06

08

10

12

14

16

18

20

22

24

26



Bloomberg

Die Top 5

der meistgefragten
Aktien unserer Leser



Platz	Anfragen	Aktientitel
1	3.245	?
2	2.387	?
3	1.637	?
4	1.346	?
5	896	Starbucks

Die Top 5

der meistgefragten
Aktien unserer Leser



Platz	Anfragen	Aktientitel
1	3.245	?
2	2.387	?
3	1.637	?
4	1.346	NextEra
5	896	Starbucks

USD



90

40

16

6

96

98

00

02

04

06

08

10

12

14

16

18

20

22

24

26

Bloomberg



USD

NEXtera
ENERGY



90

40

16

6

96

98

00

02

04

06

08

10

12

14

16

18

20

22

24

26



Bloomberg

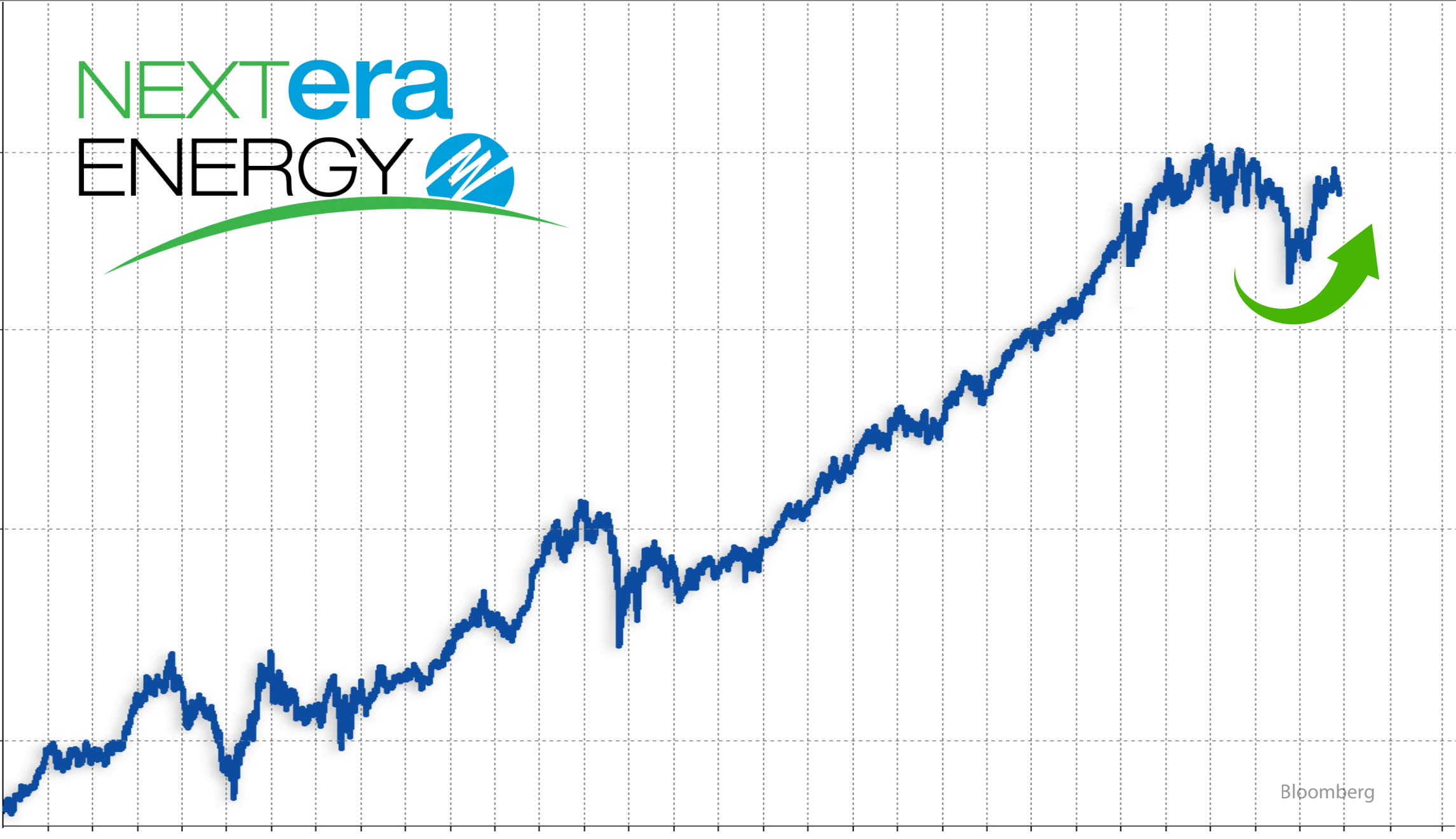

USD

NEXtera
ENERGY

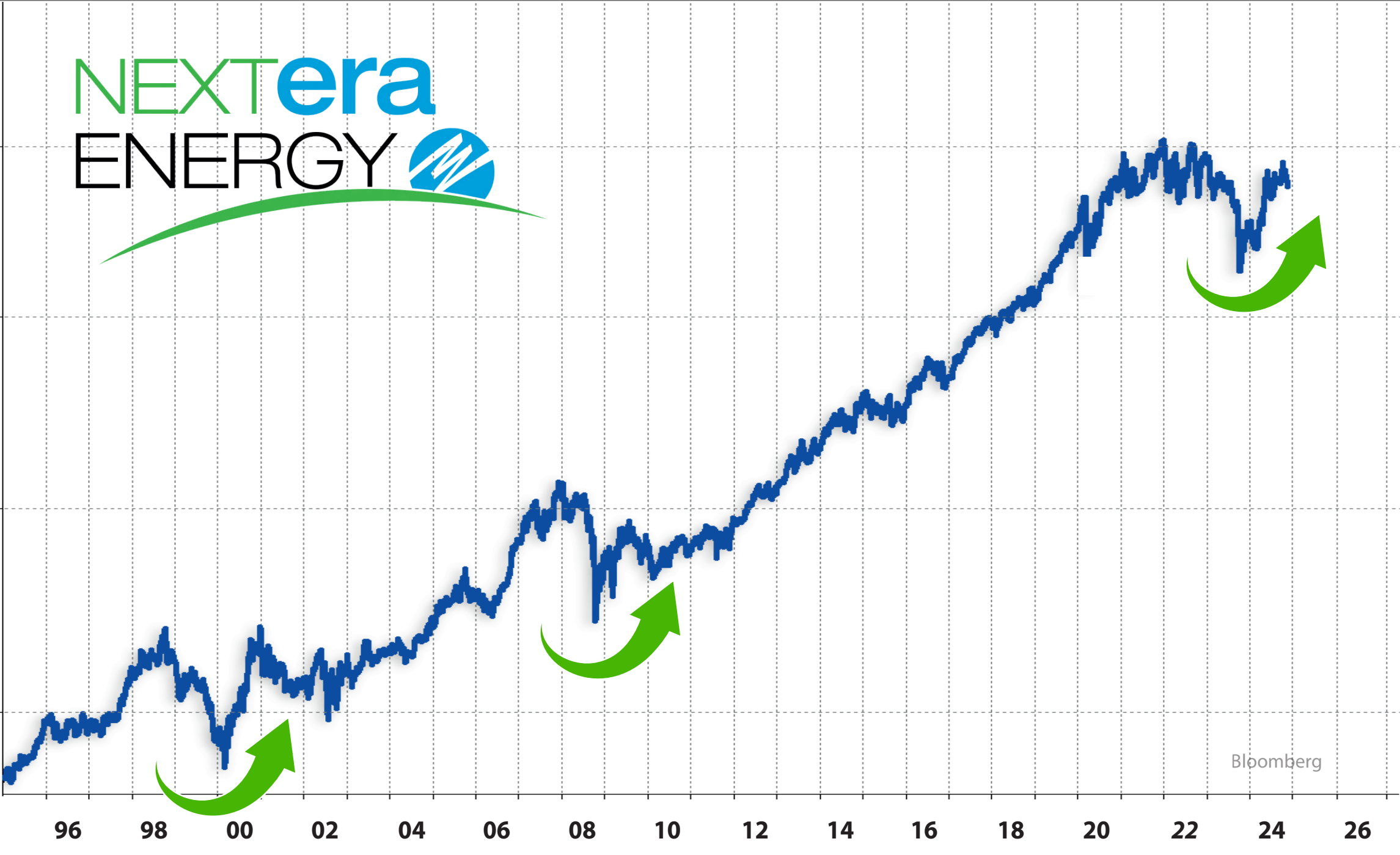

Bloomberg

USD

NEXtera ENERGY

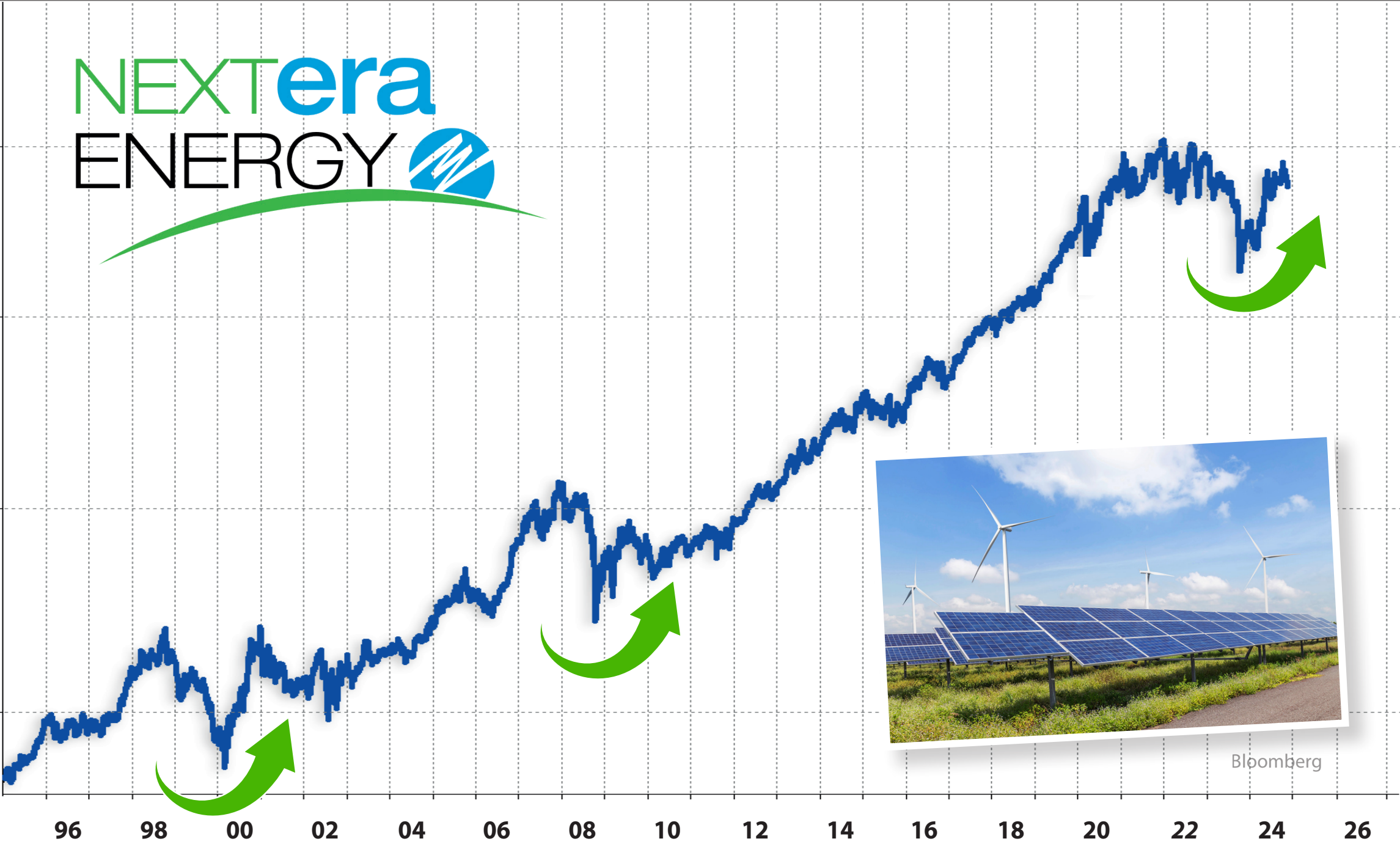

Bloomberg

Die Top 5

der meistgefragten
Aktien unserer Leser



Platz	Anfragen	Aktientitel
1	3.245	?
2	2.387	?
3	1.637	?
4	1.346	NextEra
5	896	Starbucks

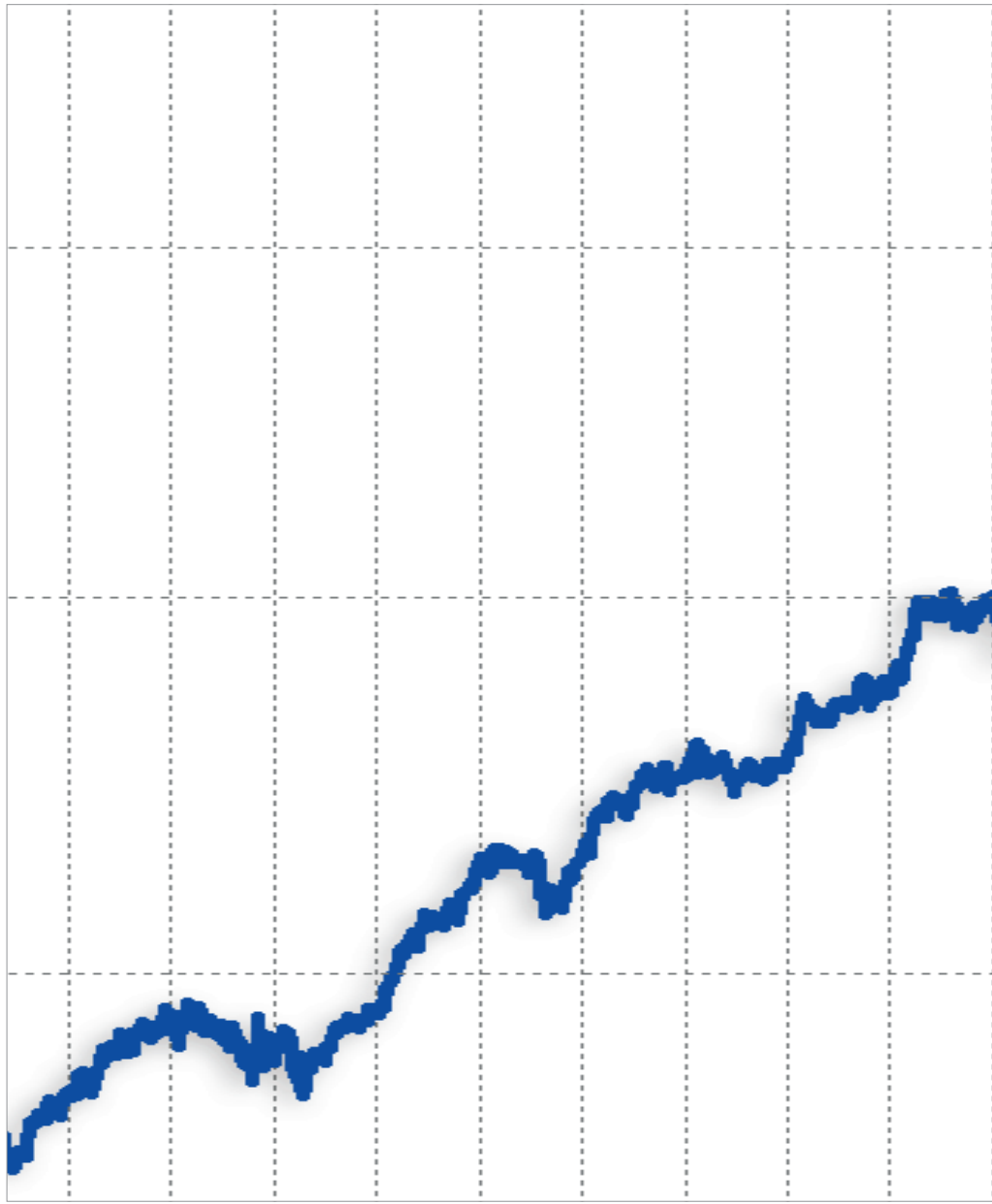

07 08 09 10 11 12 13 14 15

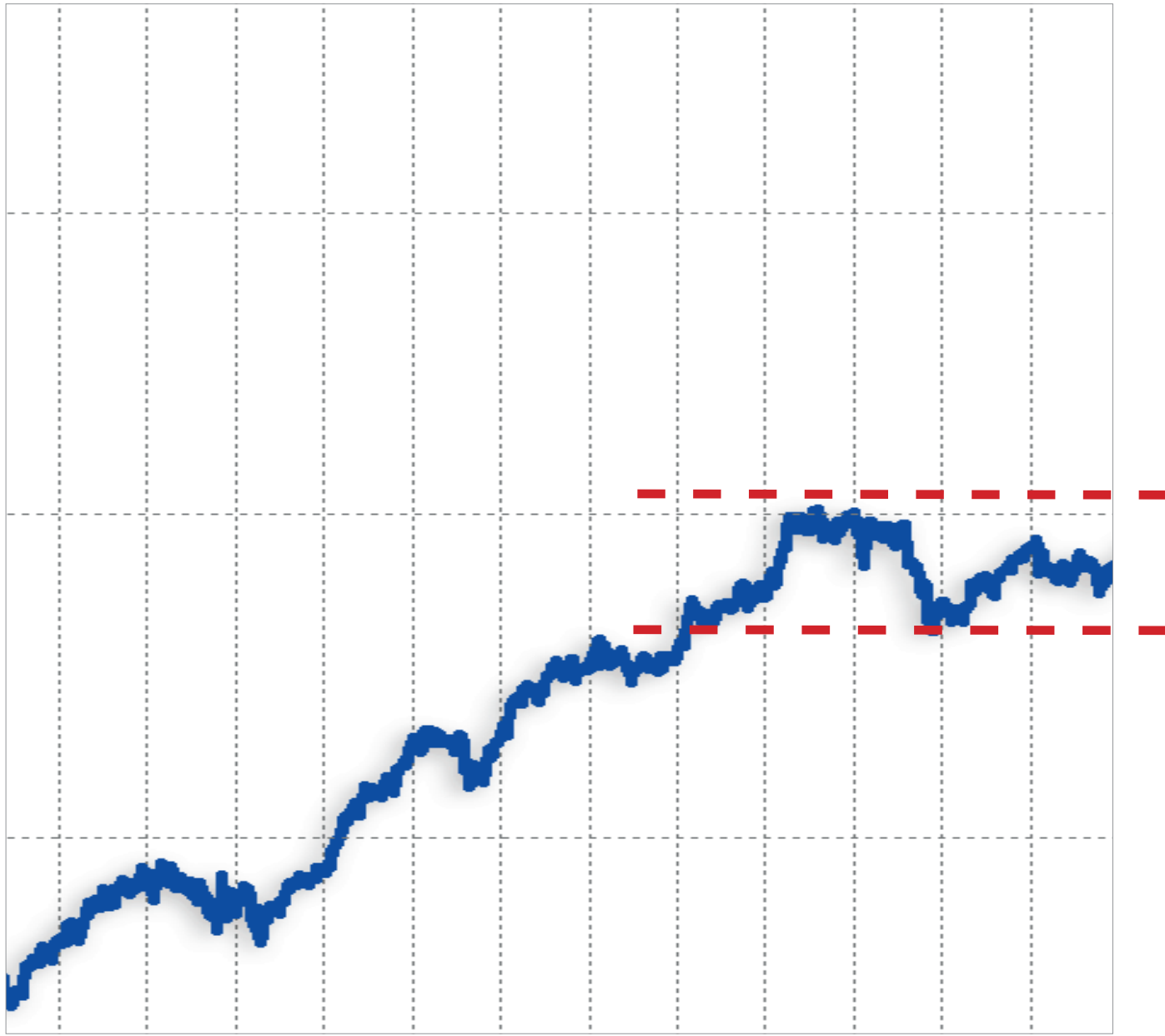

07 08 09 10 11 12 13 14 15 16 17 18



DKK

900

200

40



Bloomberg

07 08 09 10 11 12 13 14 15 16 17 18 19 20 21 22 23 24 25 26



novo nordisk

DKK

900

200

40



Bloomberg

Die Top 5

der meistgefragten
Aktien unserer Leser



Platz	Anfragen	Aktientitel
1	3.245	?
2	2.387	?
3	1.637	Novo Nordisk
4	1.346	NextEra
5	896	Starbucks

Die Top 5

der meistgefragten
Aktien unserer Leser



Platz	Anfragen	Aktientitel
1	3.245	?
2	2.387	Nike
3	1.637	Novo Nordisk
4	1.346	NextEra
5	896	Starbucks

USD

NIKE

170

30

5

1

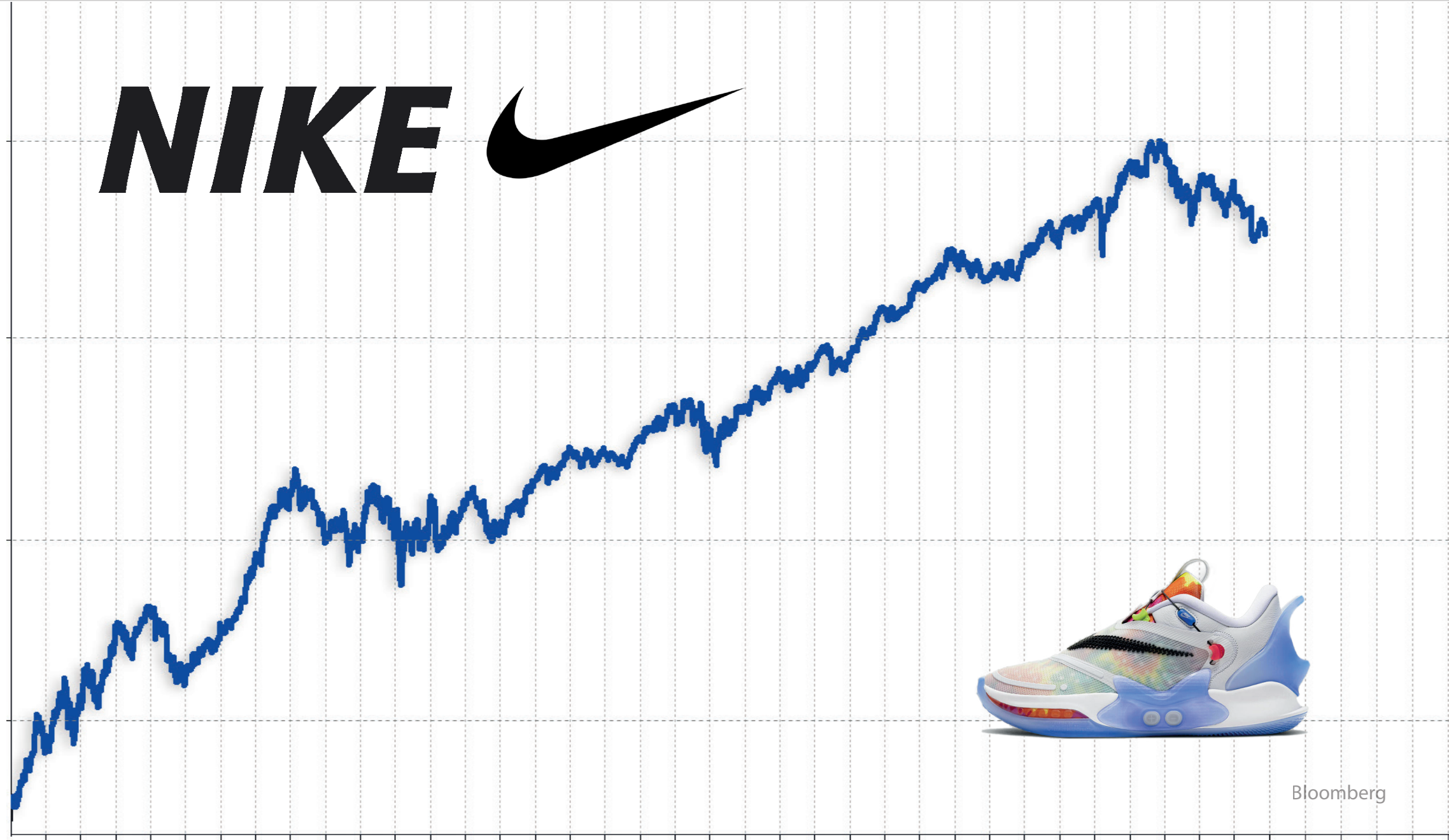

Bloomberg

USD

NIKE

170

30

5

1

90 92 94 96 98 00 02 04 06 08 10 12 14 16 18 20 22 24 26 28



Bloomberg

USD



Gewinn in Milliarden US-Dollar

Gewinn in
Mrd. USD

6,0

4,0

2,0

1,0

0,5

0,3

170

30

5

1

90 92 94 96 98 00 02 04 06 08 10 12 14 16 18 20 22 24 26 28

Bloomberg

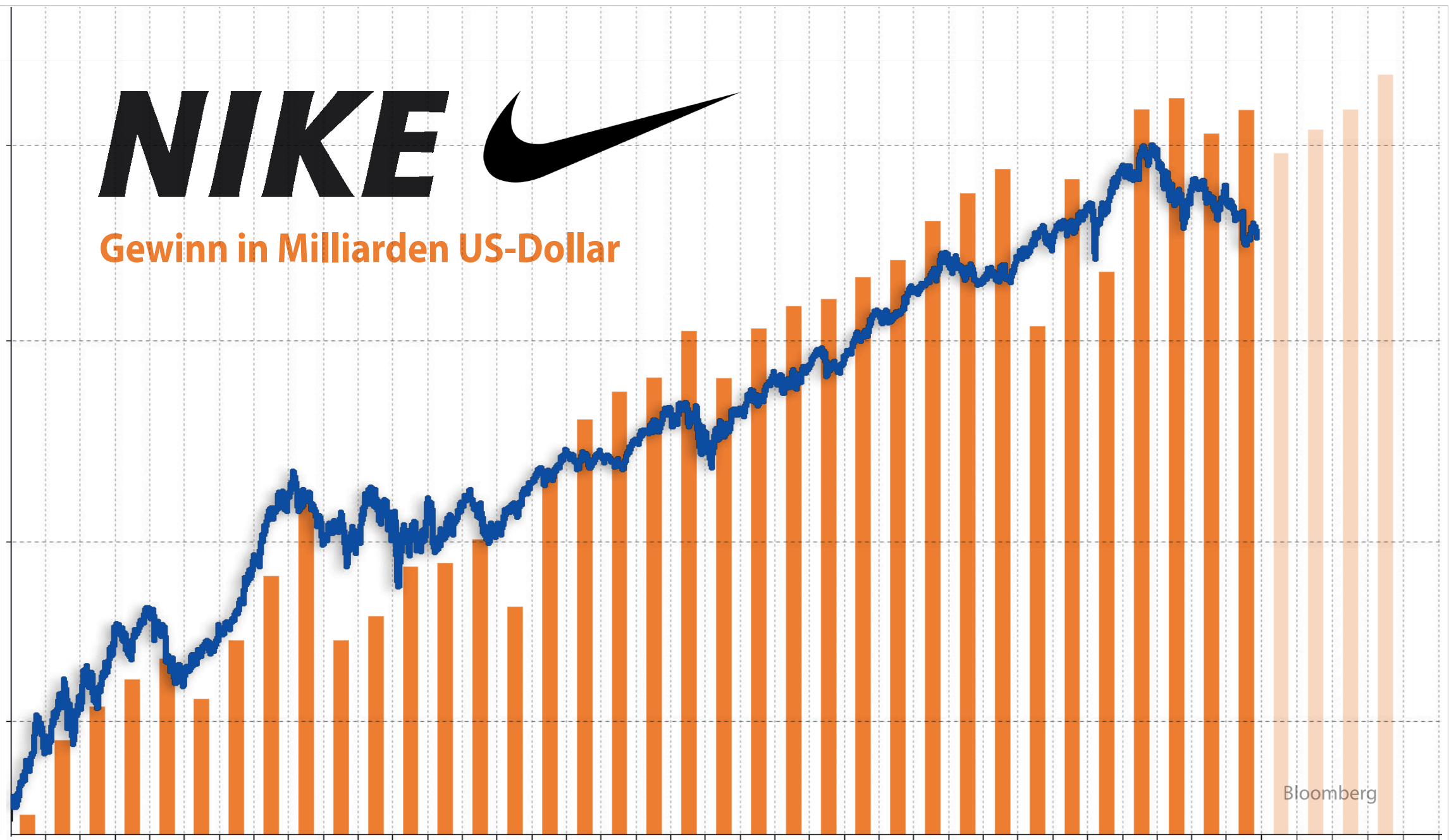



PARIS 2024

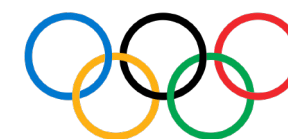





USD

NIKE

170

30

5

1

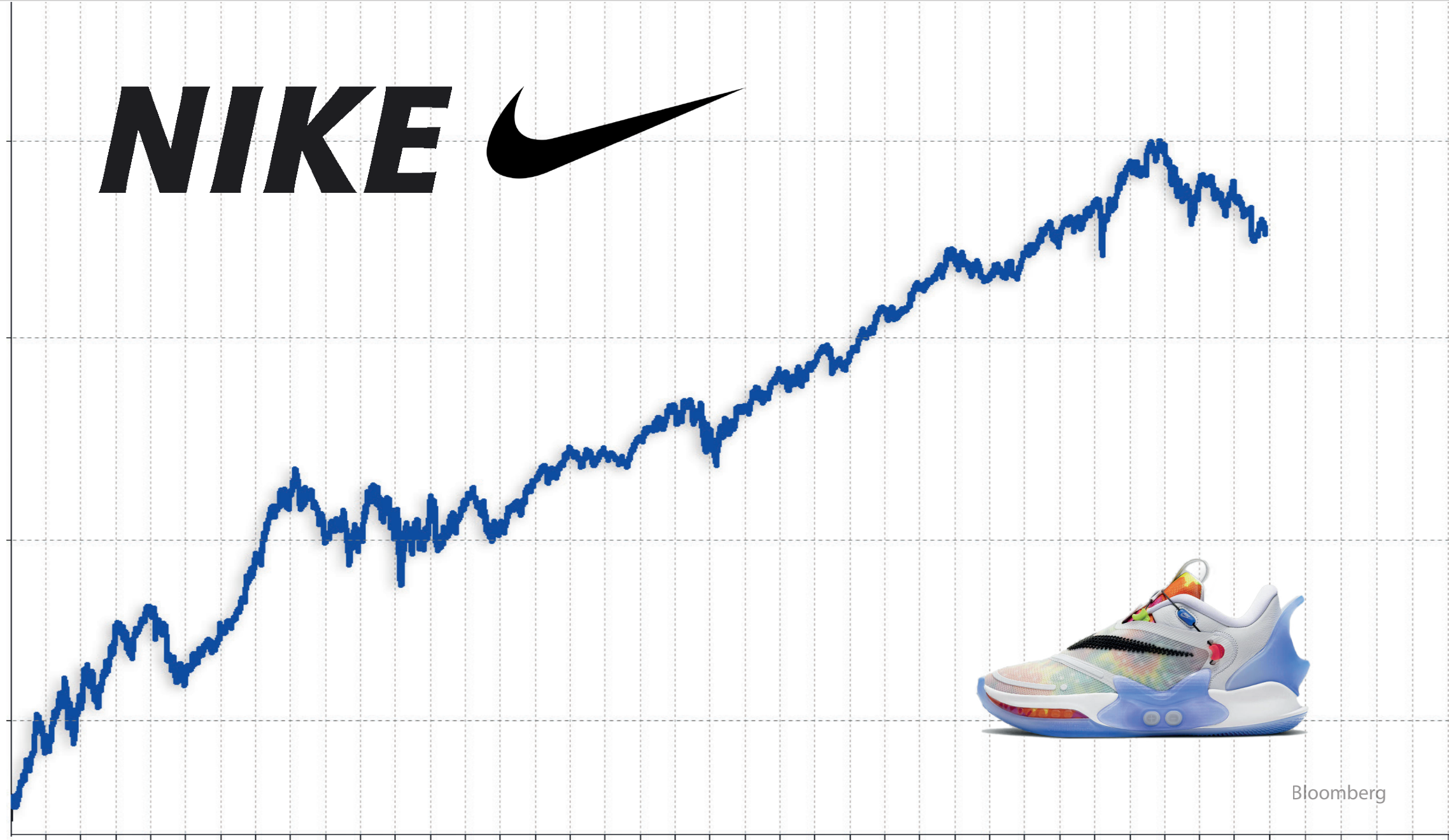

Bloomberg

Die Top 5

der meistgefragten
Aktien unserer Leser



Platz	Anfragen	Aktientitel
1	3.245	?
2	2.387	Nike
3	1.637	Novo Nordisk
4	1.346	NextEra
5	896	Starbucks

Die Top 5

der meistgefragten
Aktien unserer Leser



Platz	Anfragen	Aktientitel
1	3.245	Nibe
2	2.387	Nike
3	1.637	Novo Nordisk
4	1.346	NextEra
5	896	Starbucks

SEK



130

30

5

09 10 11 12 13 14 15 16 17 18 19 20 21 22 23 24 25 26 27 28

Bloomberg

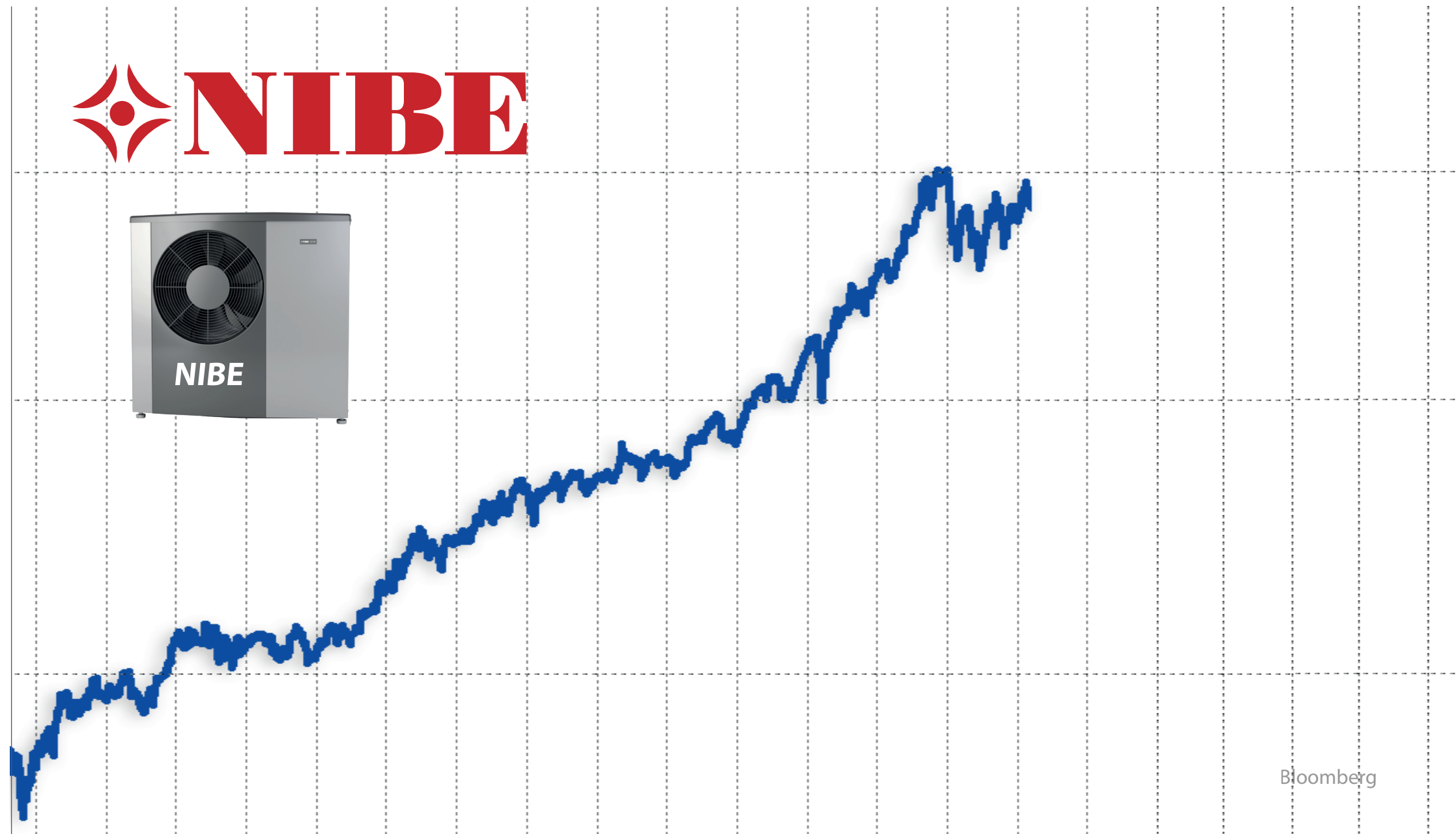

SEK



130

30

5

09 10 11 12 13 14 15 16 17 18 19 20 21 22 23 24 25 26 27 28

Bloomberg

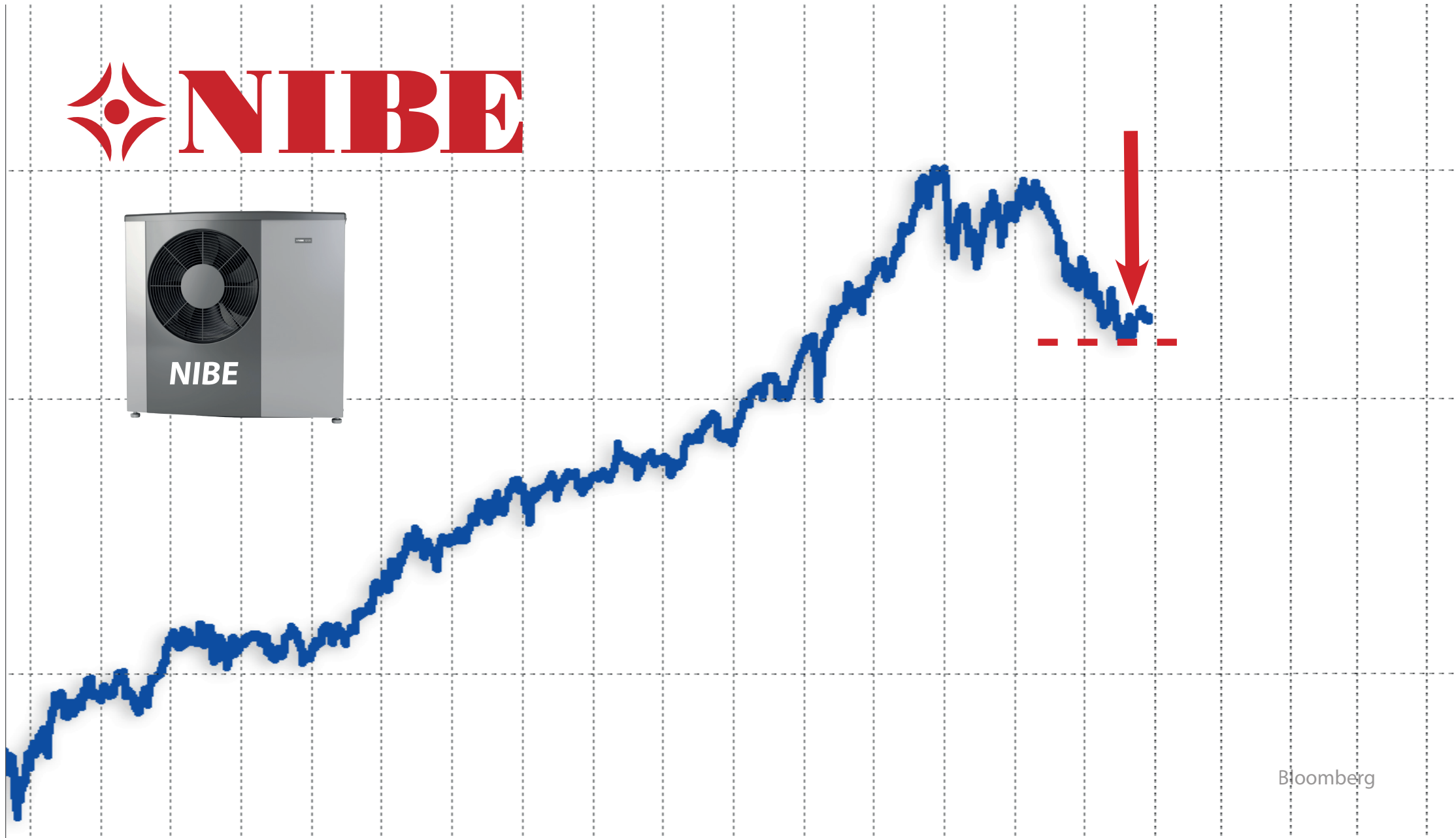

NETFLIX

USD

650

100

10

08

09

10

11

12

13

14

15

16

17

18

19

20

21

22

23

24

25

26

Bloomberg



NETFLIX

USD

650

100

10

Steigende Inflation –
Konsumenten sparen



08 09 10 11 12 13 14 15 16 17 18 19 20 21 22 23 24 25 26

Bloomberg



NETFLIX

USD

650

100

10

08 09 10 11 12 13 14 15 16 17 18 19 20 21 22 23 24 25 26

Steigende Inflation –
Konsumenten sparen

Streamingdienste machen dicht



Bloomberg



NETFLIX

USD

650

100

10

08

09

10

11

12

13

14

15

16

17

18

19

20

21

22

23

24

25

26

Steigende Inflation –
Konsumenten sparen

Streamingdienste machen dicht

Abonnenten laufen davon

Langeweile zieht ein

Bloomberg



NETFLIX

USD

650

100

10

08 09 10 11 12 13 14 15 16 17 18 19 20 21 22 23 24 25 26

Steigende Inflation –
Konsumenten sparen

Streamingdienste machen dicht

Abonnenten laufen davon

Langeweile zieht ein

Quartalsgewinn schrumpft

Starker Umsatzrückgang

Bloomberg

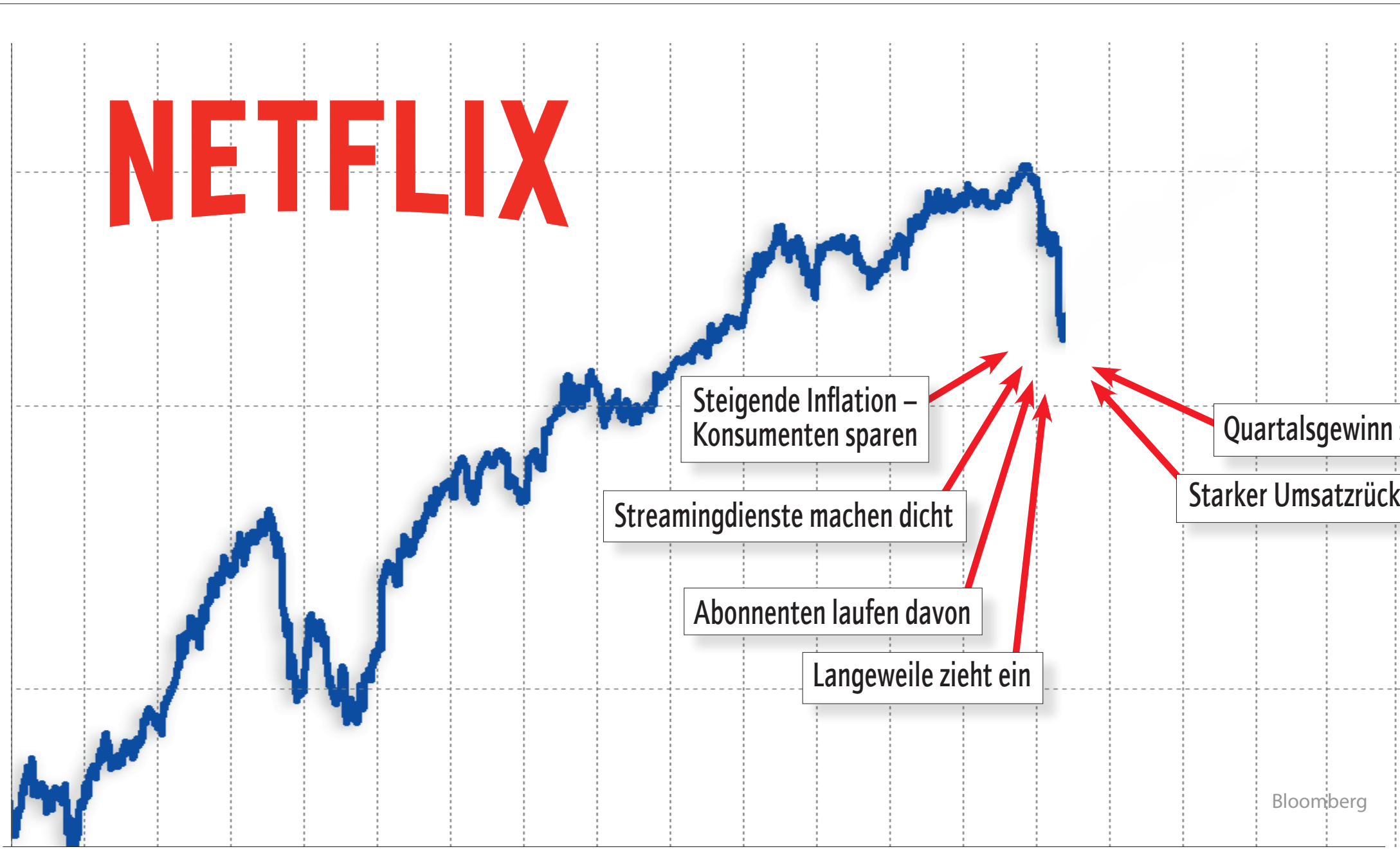

NETFLIX

USD

650

100

10

08 09 10 11 12 13 14 15 16 17 18 19 20 21 22 23 24 25 26

Steigende Inflation –
Konsumenten sparen

Streamingdienste machen dicht

Abonnenten laufen davon

Langeweile zieht ein

Quartalsgewinn schrumpft

Starker Umsatzrückgang

Mitarbeiterentlassungen

Bloomberg

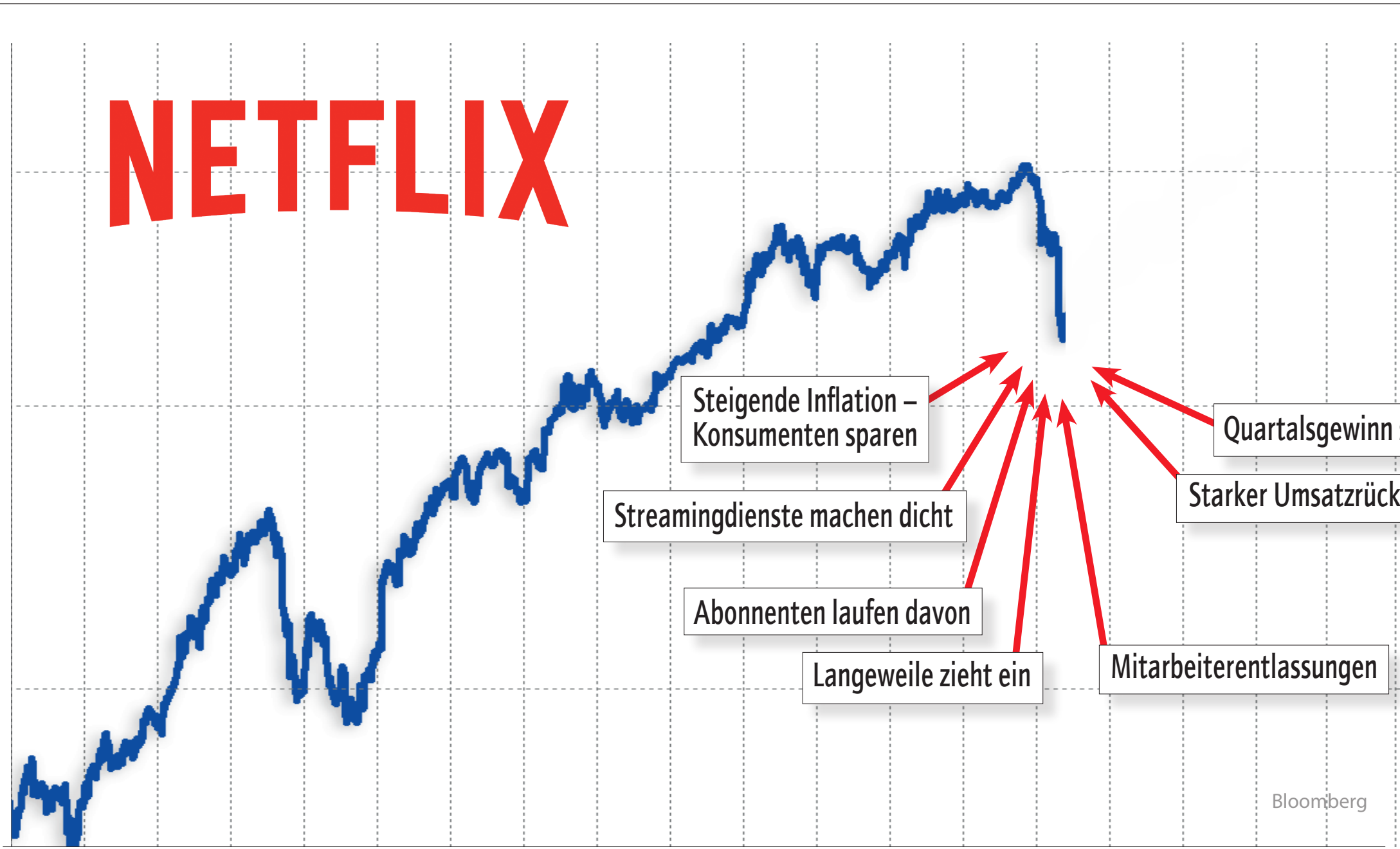

NETFLIX

USD

650

100

10

08

09

10

11

12

13

14

15

16

17

18

19

20

21

22

23

24

25

26

Streamingdienste machen dicht

Abonnenten laufen davon

Langeweile zieht ein

Steigende Inflation –
Konsumenten sparen

Mitarbeiterentlassungen

Starker Umsatzrückgang

Extrem hoher
Konkurrenzdruck

Quartalsgewinn schrumpft

Bloomberg

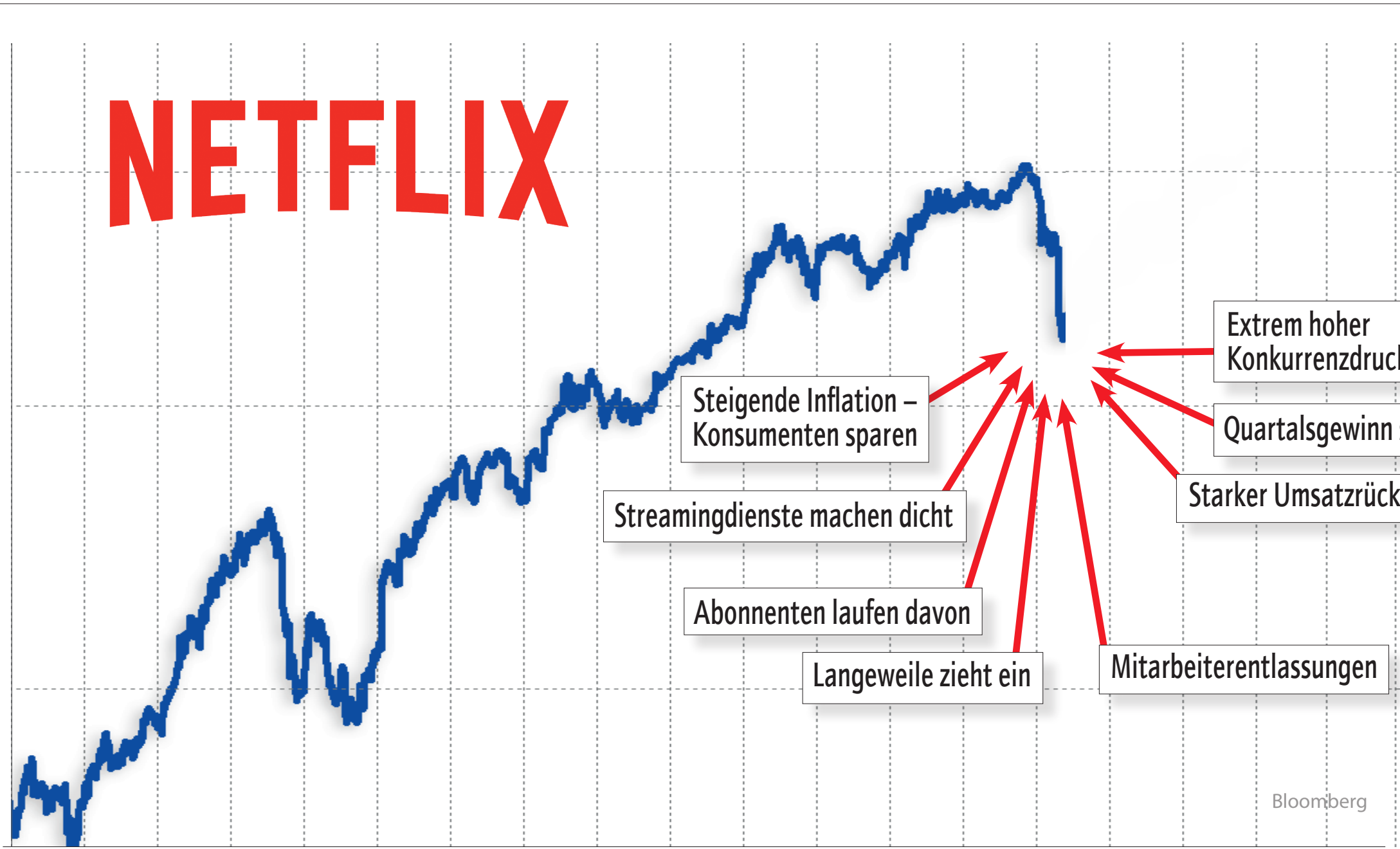

NETFLIX

USD

650

100

10

08 09 10 11 12 13 14 15 16 17 18 19 20 21 22 23 24 25 26

- Steigende Inflation – Konsumenten sparen
- Streamingdienste machen dicht
- Abonnenten laufen davon
- Langeweile zieht ein
- Mitarbeiterentlassungen
- Extrem hoher Konkurrenzdruck
- Quartalsgewinn schrumpft
- Starker Umsatzrückgang

Die Streamingblase ist geplatzt!

Bloomberg

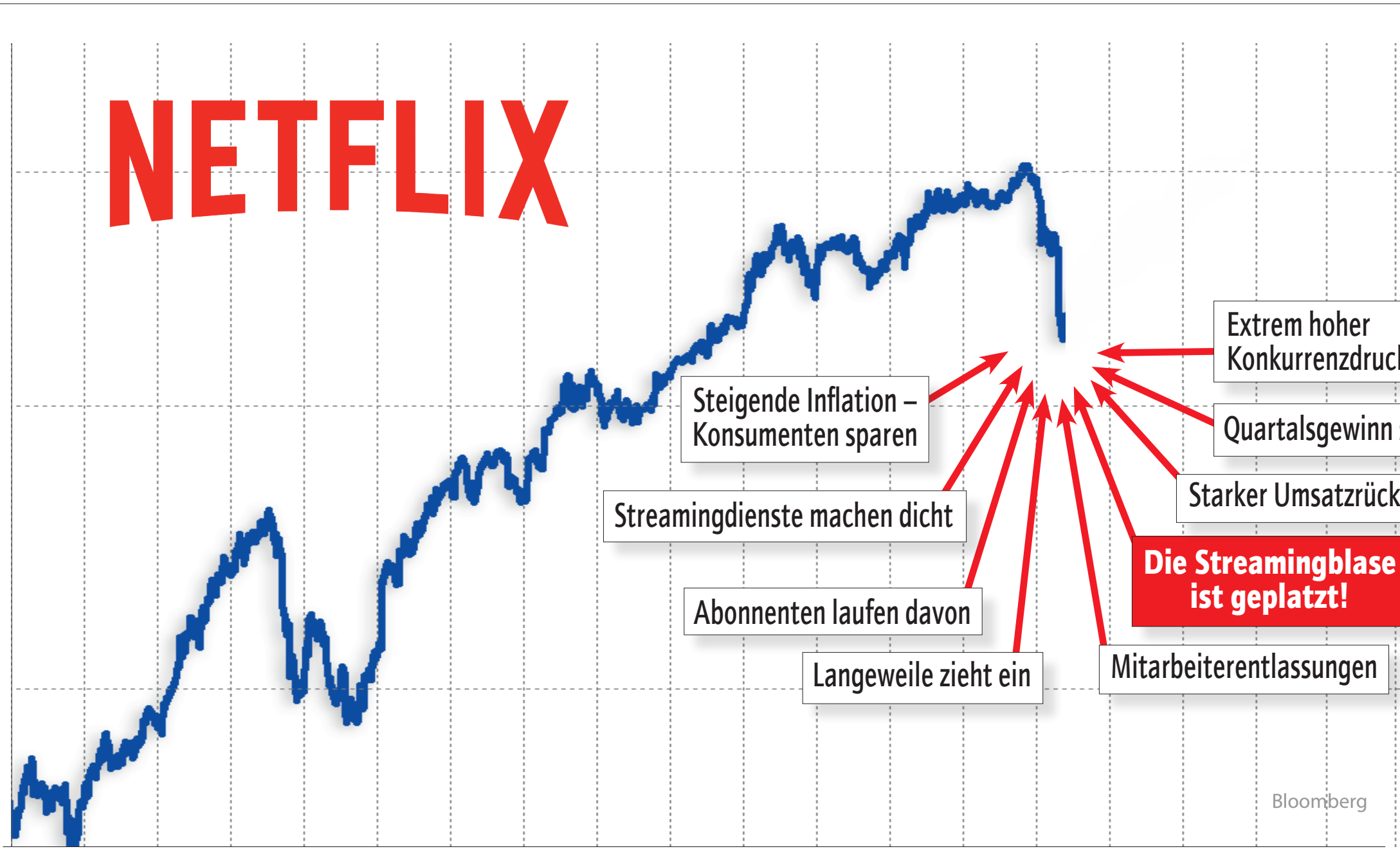

NETFLIX

USD

650

100

10

08 09 10 11 12 13 14 15 16 17 18 19 20 21 22 23 24 25 26

Streamingdienste machen dicht

Abonnenten laufen davon

Langeweile zieht ein

Steigende Inflation – Konsumenten sparen

Extrem hoher Konkurrenzdruck

Quartalsgewinn schrumpft

Starker Umsatzrückgang

Die Streamingblase ist geplatzt!

Mitarbeiterentlassungen

Bloomberg

SEK



130

30

5

09 10 11 12 13 14 15 16 17 18 19 20 21 22 23 24 25 26 27 28

Bloomberg

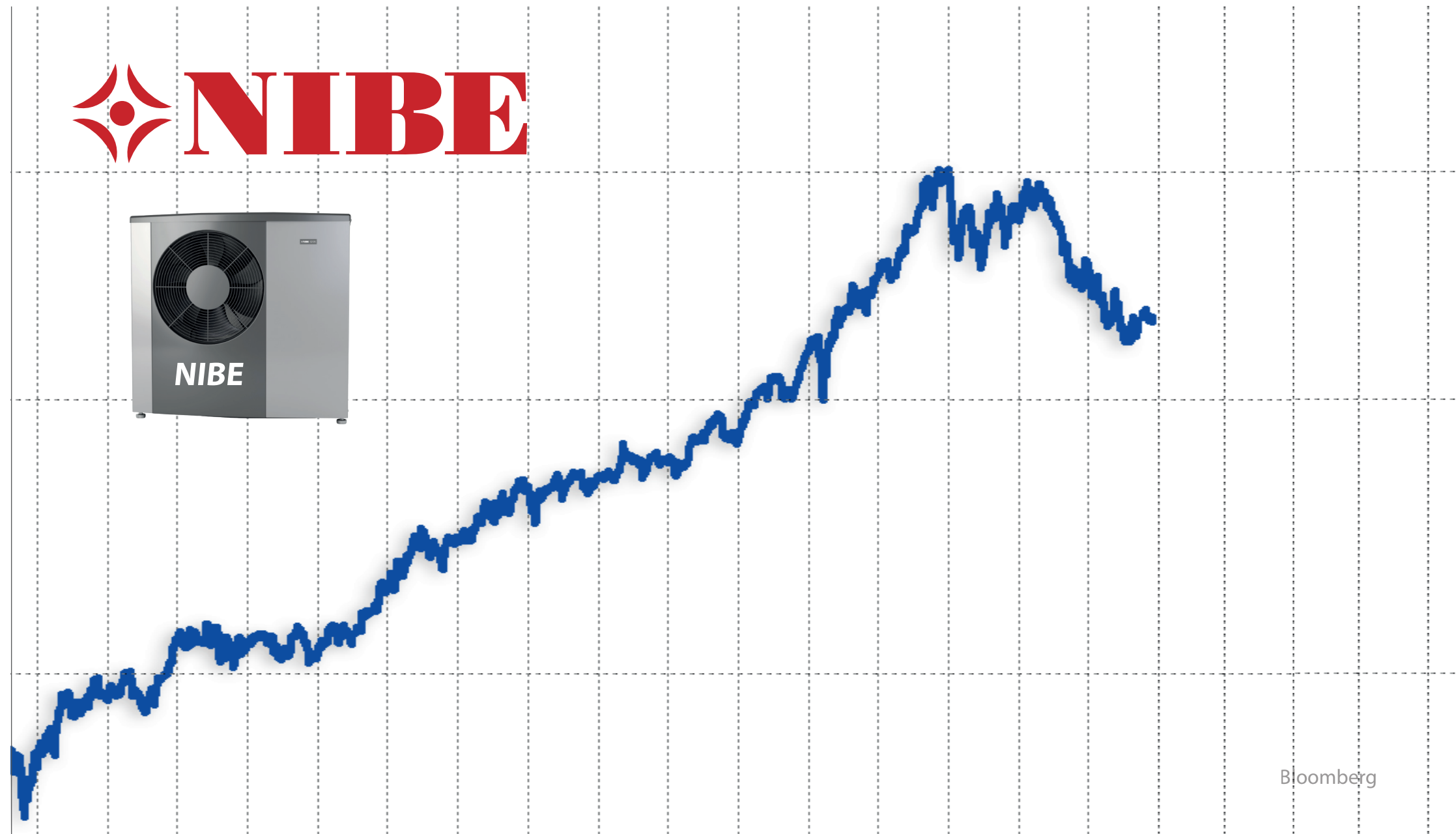



Erwartetes Marktvolumen Wärmepumpen (weltweit)

in Milliarden US-Dollar

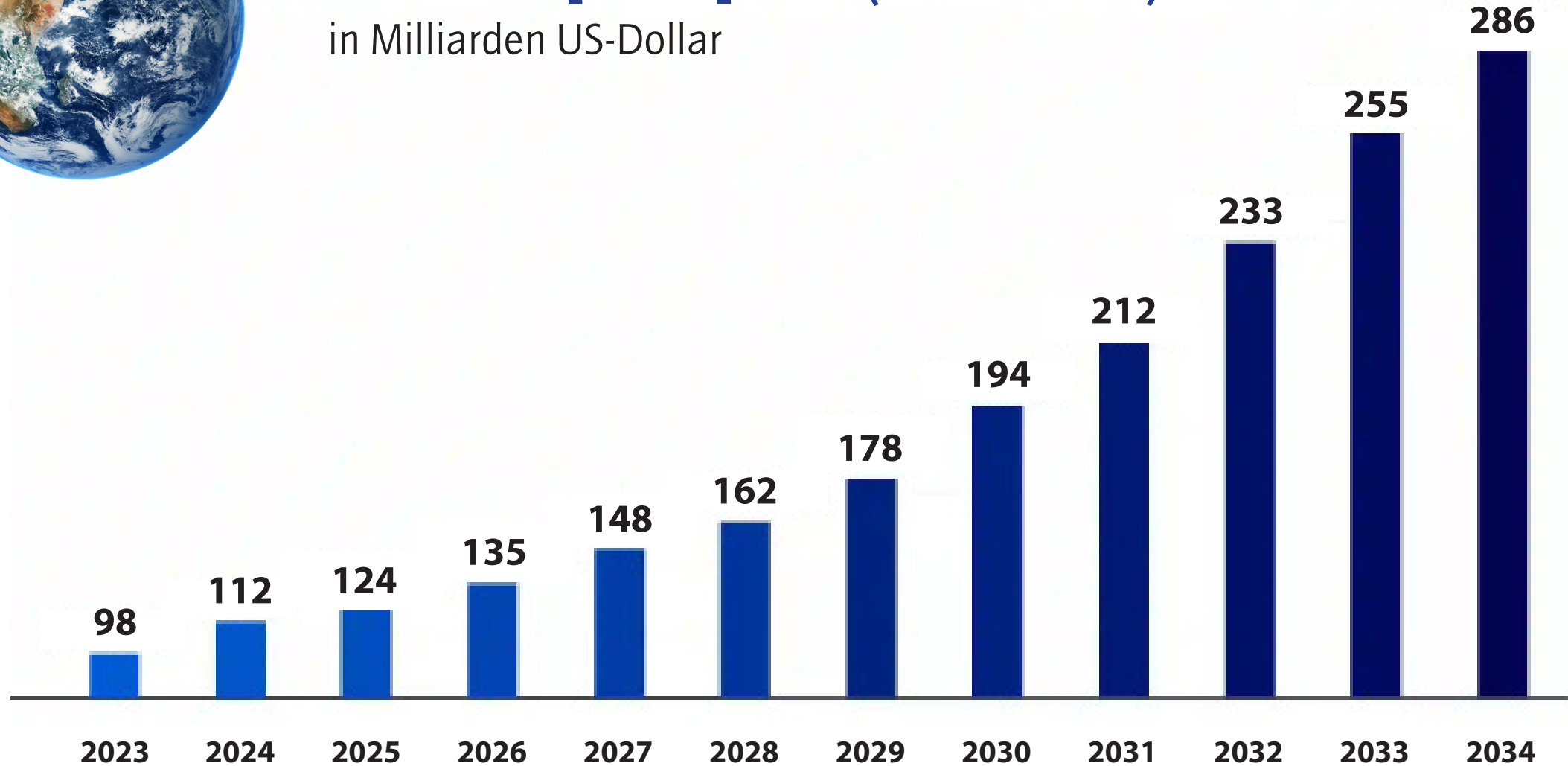

SEK



130

30

5

09 10 11 12 13 14 15 16 17 18 19 20 21 22 23 24 25 26 27 28

Bloomberg

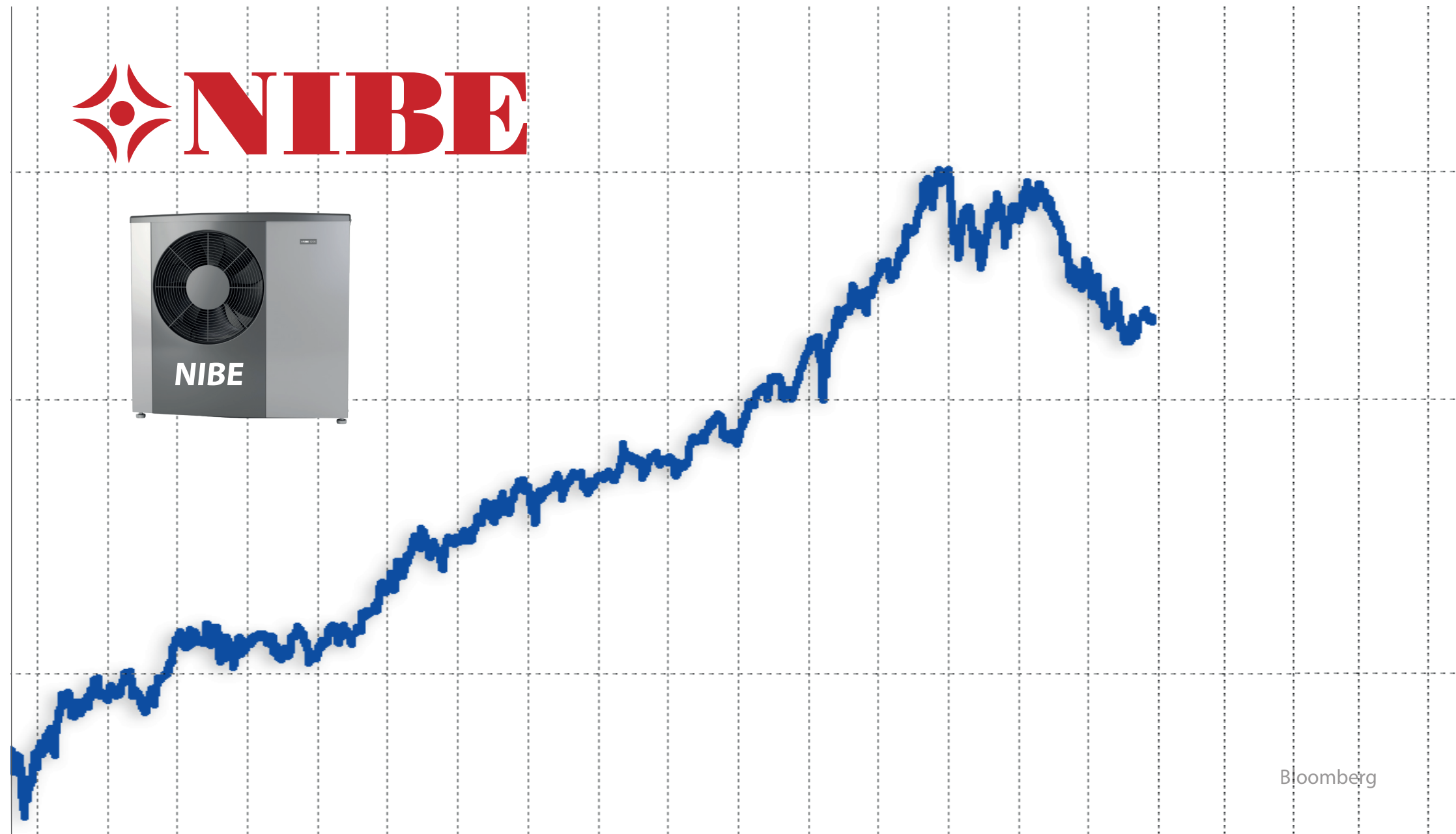

SEK



130

30

5

09 10 11 12 13 14 15 16 17 18 19 20 21 22 23 24 25 26 27 28

Bloomberg

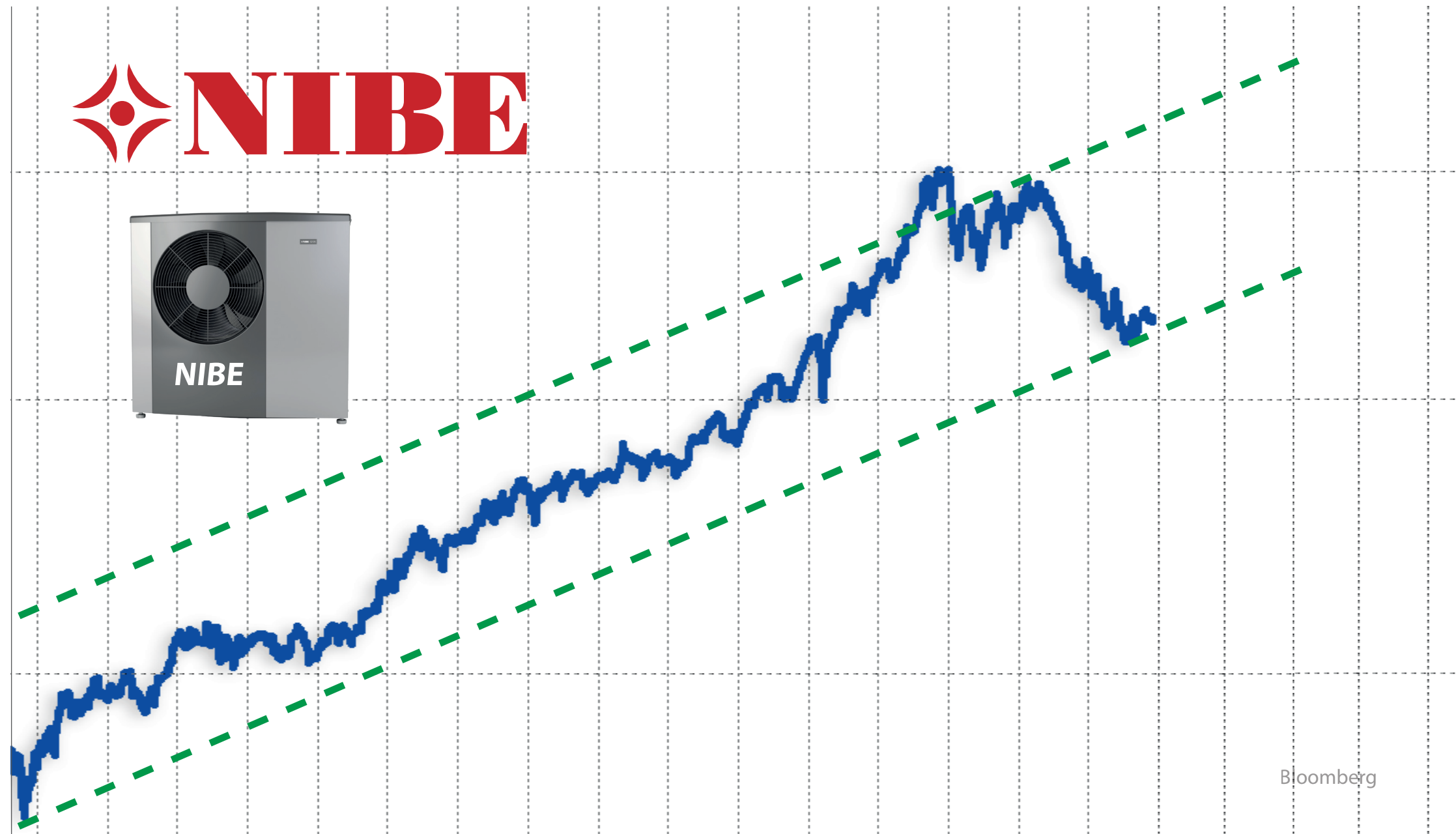

SEK



130

30

5

09

10

11

12

13

14

15

16

17

18

19

20

21

22

23

24

25

26

27

28

Bloomberg

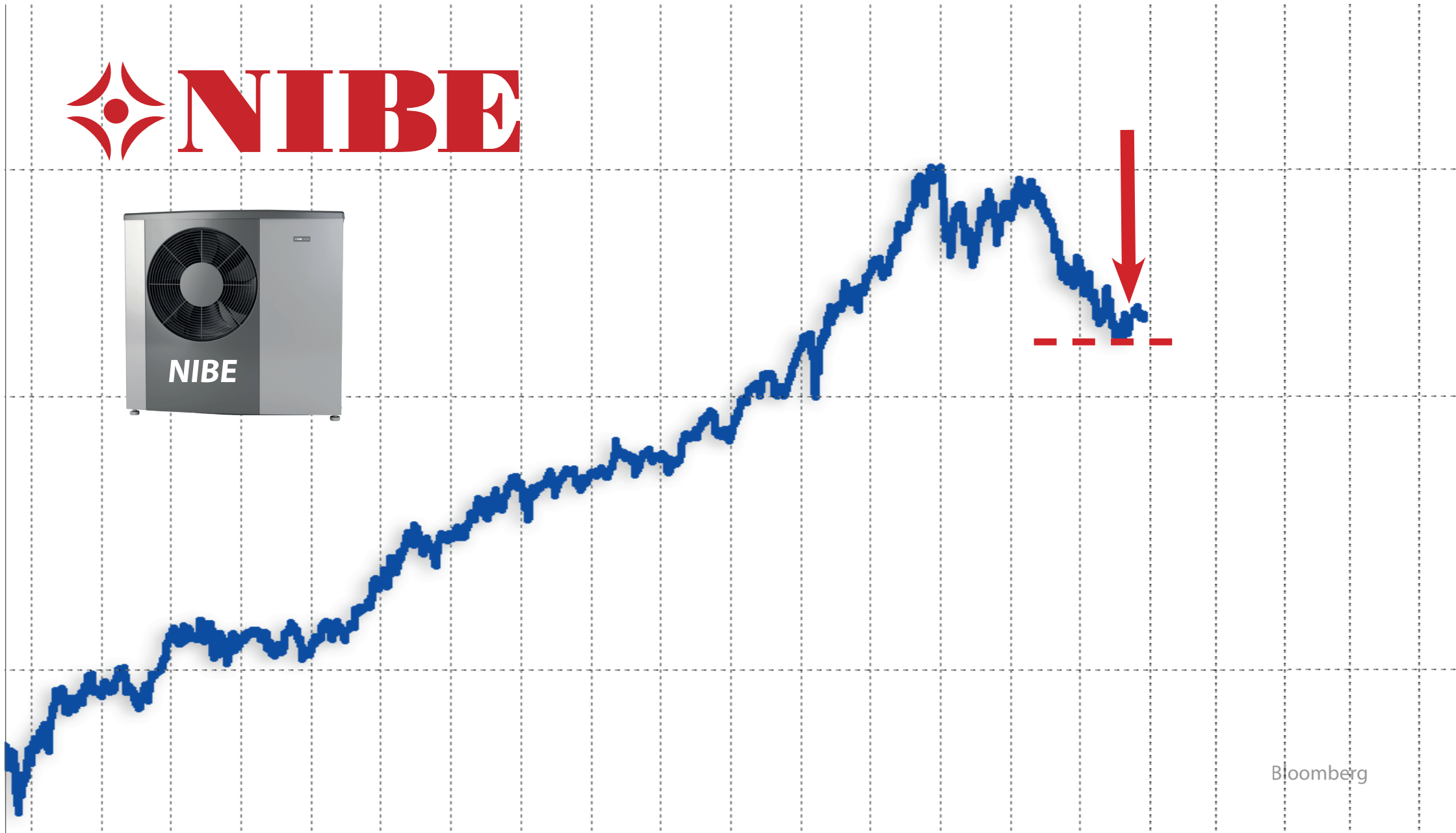

SEK



130

30

5

09 10 11 12 13 14 15 16 17 18 19 20 21 22 23 24 25 26 27 28

Bloomberg

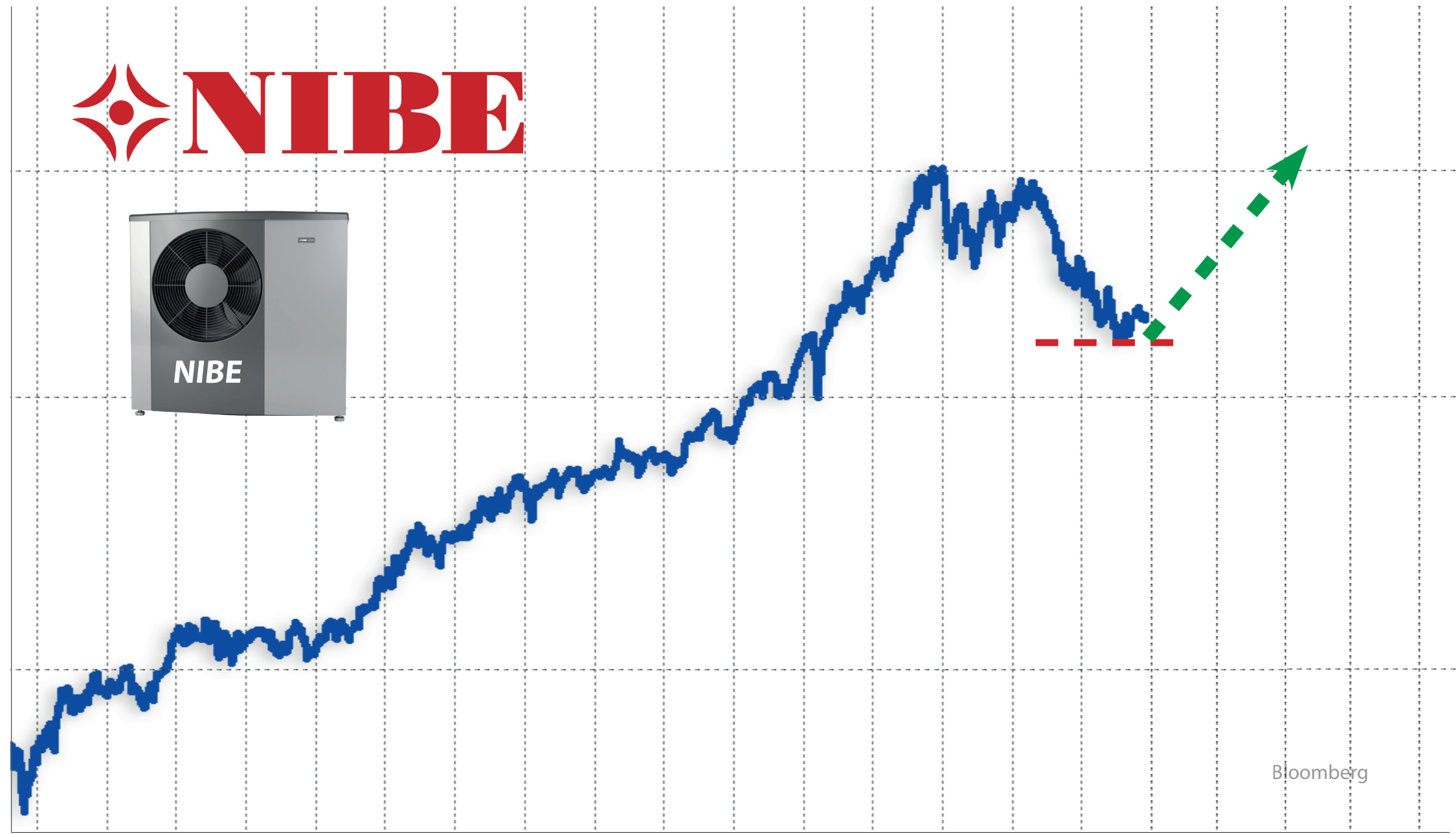



Christoph Wendling

Die Überlegenheit der Aktie

***„Wie viele Millionäre kennen Sie,
die durch Investitionen in Sparkonten
reich geworden sind?“***

Robert G. Allen, US-Finanzexperte

Auswahlkriterien bei der Geldanlage

Kosten

Laufzeit

Nachhaltigkeit

Rendite

Serviceangebot

Komplexität

Ansprechpartner

Sicherheit

Verfügbarkeit

kleiner Mindestanlagebetrag

Auswahlkriterien bei der Geldanlage

Kosten

Laufzeit

Nachhaltigkeit

Rendite

Serviceangebot

Komplexität

Ansprechpartner

Sicherheit

Verfügbarkeit

kleiner Mindestanlagebetrag

Auswahlkriterien bei der Geldanlage

Kosten

Laufzeit

Nachhaltigkeit

Rendite

Serviceangebot

Komplexität

Ansprechpartner

Sicherheit

Verfügbarkeit

kleiner Mindestanlagebetrag

Auswahlkriterien bei der Geldanlage

Kosten

Laufzeit

Nachhaltigkeit

Rendite

Serviceangebot

Komplexität

Ansprechpartner

Sicherheit

Verfügbarkeit

kleiner Mindestanlagebetrag

Auswahlkriterien bei der Geldanlage

Kosten

Laufzeit

Nachhaltigkeit

Rendite

Serviceangebot

Komplexität

Ansprechpartner

Sicherheit

Verfügbarkeit

kleiner Mindestanlagebetrag

Deutsche gehen auf Nummer sicher

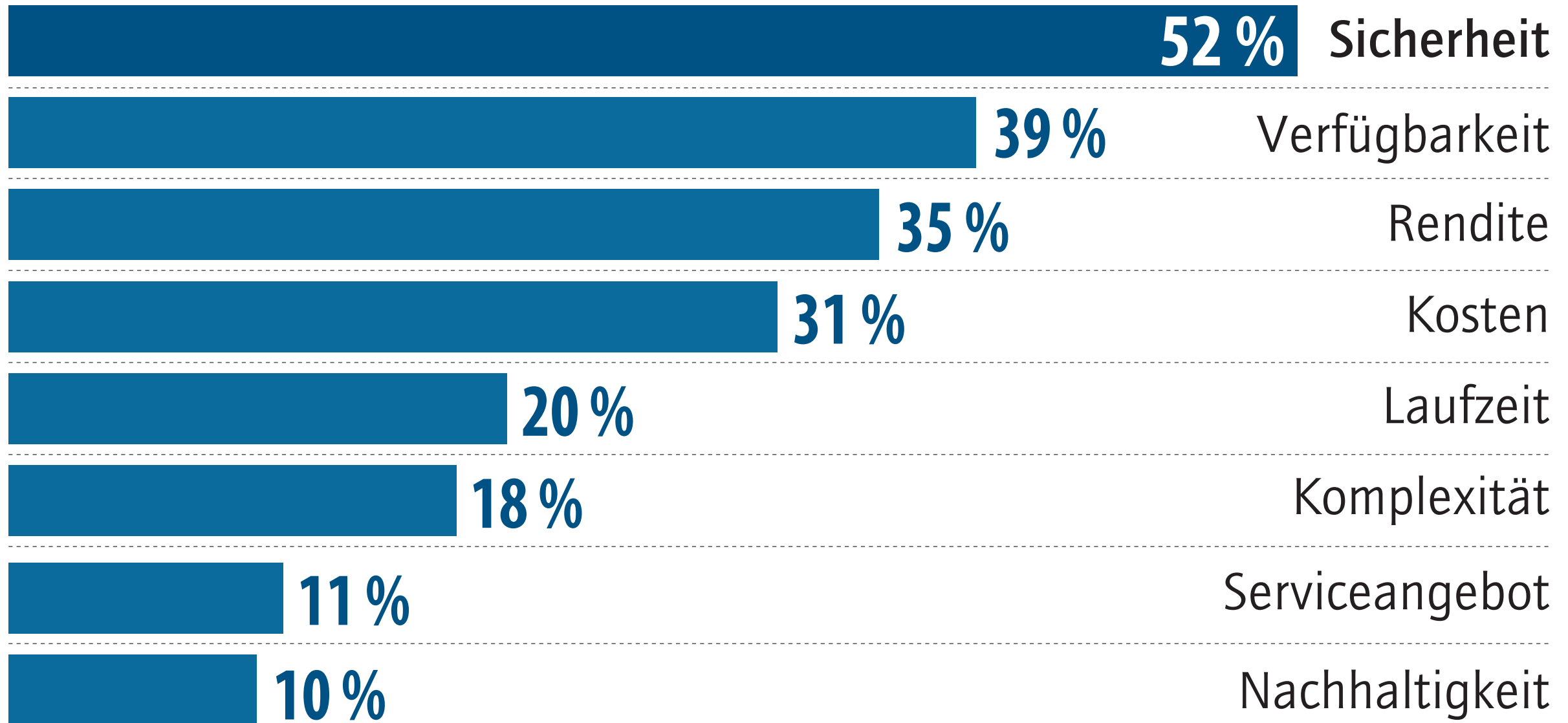

Wie viele Deutsche haben Aktien?



Wie viele Deutsche haben Aktien?



18 %
haben Aktien



Wie viele Deutsche haben Aktien?



82 %
haben keine Aktien



18 %
haben Aktien

Geldwerte

Bargeld

Anleihen

Sparkonto

Termineinlagen

Lebensversicherung



Geldwerte

Bargeld

Anleihen

Sparkonto

Termineinlagen

Lebensversicherung



Sachwerte

Aktie

Gold

Kunst

Oldtimer

Immobilien



DAX in der Finanzkrise 2008

Punkte

8.000

6.000

5.000

4.000

3.000

2003

2004

2005

2006

2007

2008

2009

2010

2011

2012

2013

- 55%

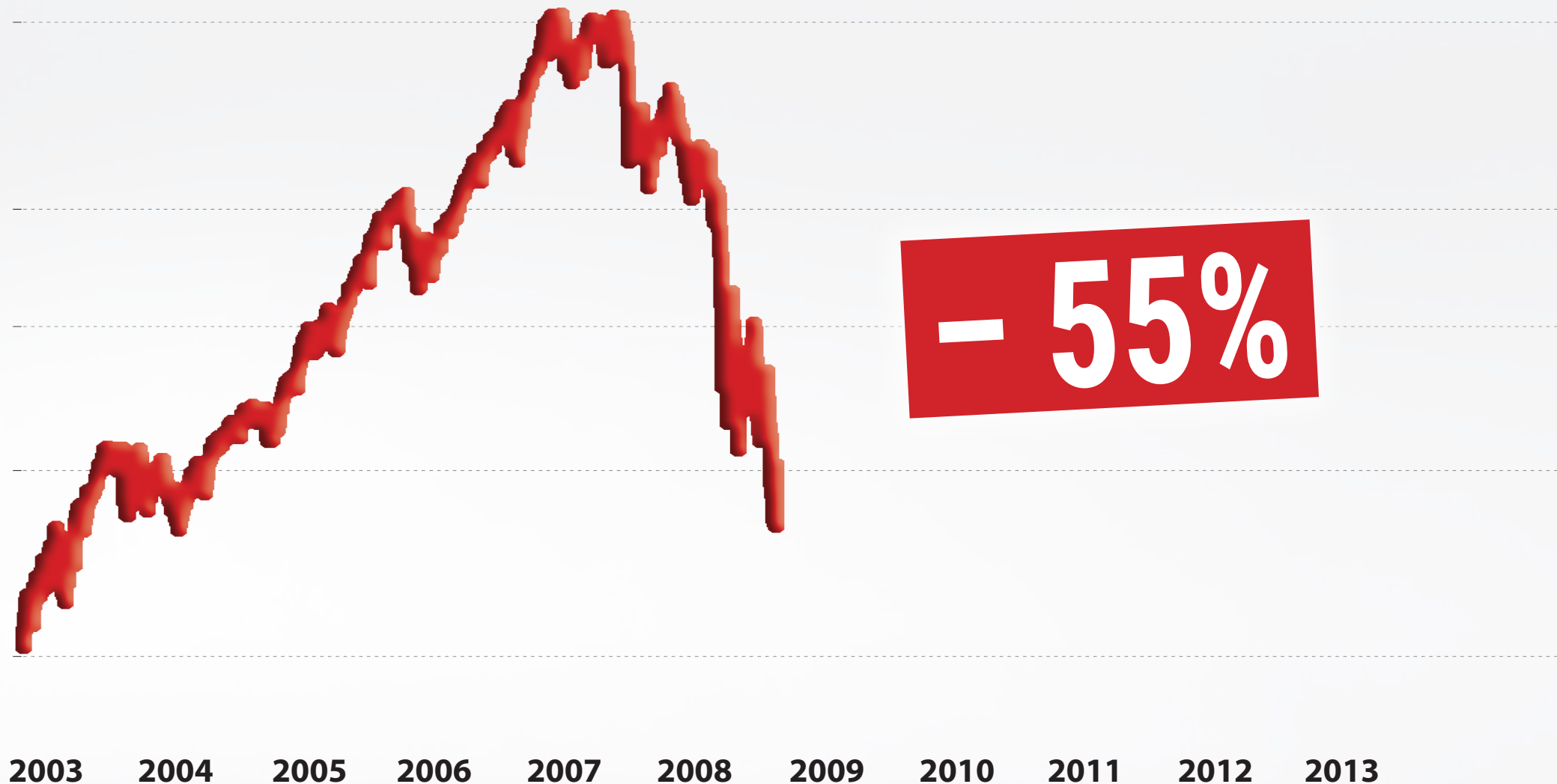

DAX nach der Finanzkrise

Punkte

8.000

6.000

5.000

4.000

3.000

2003

2004

2005

2006

2007

2008

2009

2010

2011

2012

2013

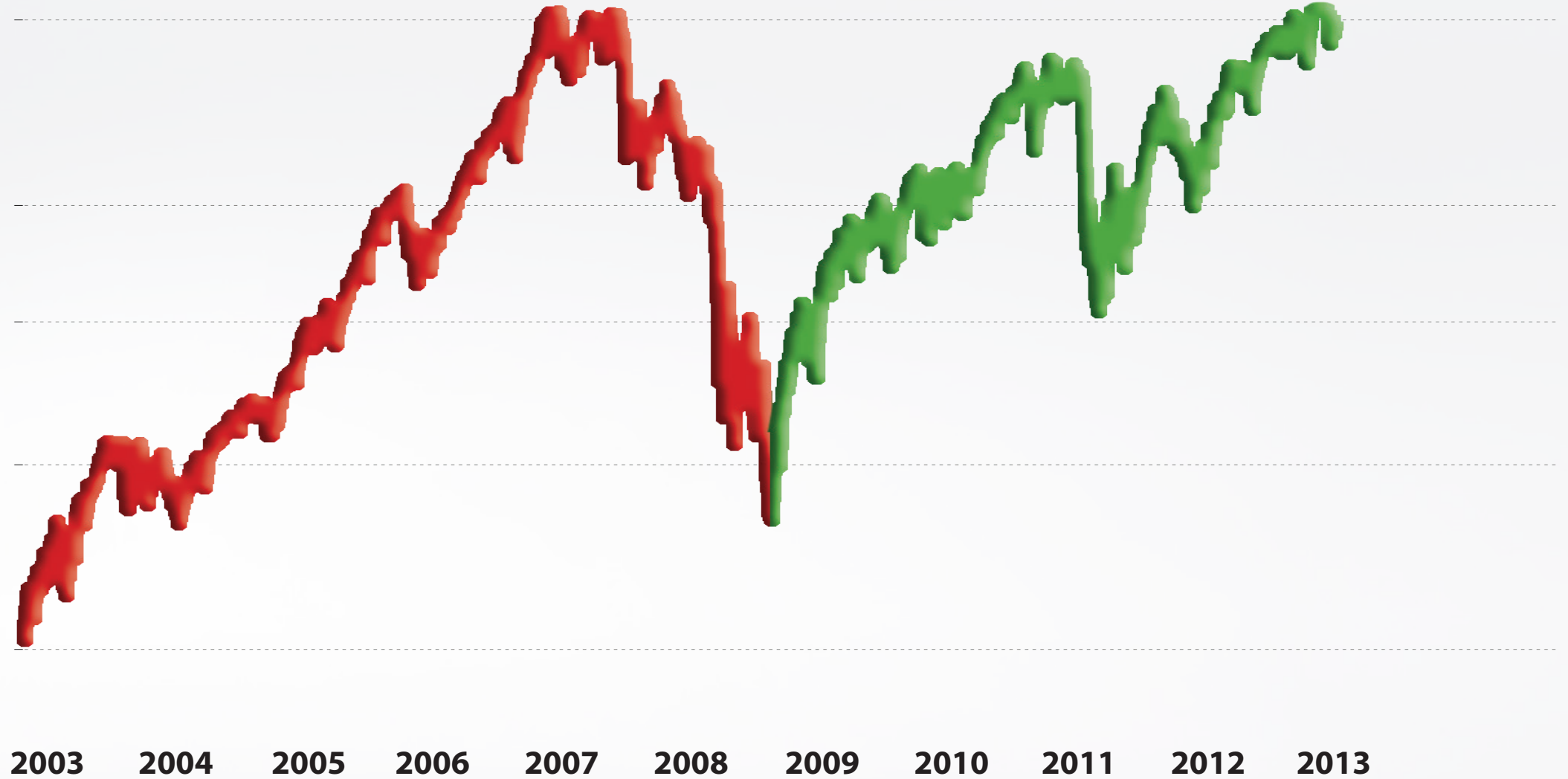

Wahrscheinlichkeit auf Kursgewinne

Anlagezeitraum

Wahrscheinlichkeit

1 Jahr:

72 %



Wahrscheinlichkeit auf Kursgewinne

Anlagezeitraum

Wahrscheinlichkeit

1 Jahr:

72 %

5 Jahre:

88 %



Wahrscheinlichkeit auf Kursgewinne



Anlagezeitraum

Wahrscheinlichkeit

1 Jahr:

72 %

5 Jahre:

88 %

10 Jahre:

95 %

Wahrscheinlichkeit auf Kursgewinne



Anlagezeitraum

Wahrscheinlichkeit

1 Jahr:

72 %

5 Jahre:

88 %

10 Jahre:

95 %

20 Jahre:

100 %

**Die beste Geldanlage
seit 1900?**

Erträge (Ø pro Jahr seit 1900)

2,5 %



Sparbuch

Erträge (Ø pro Jahr seit 1900)

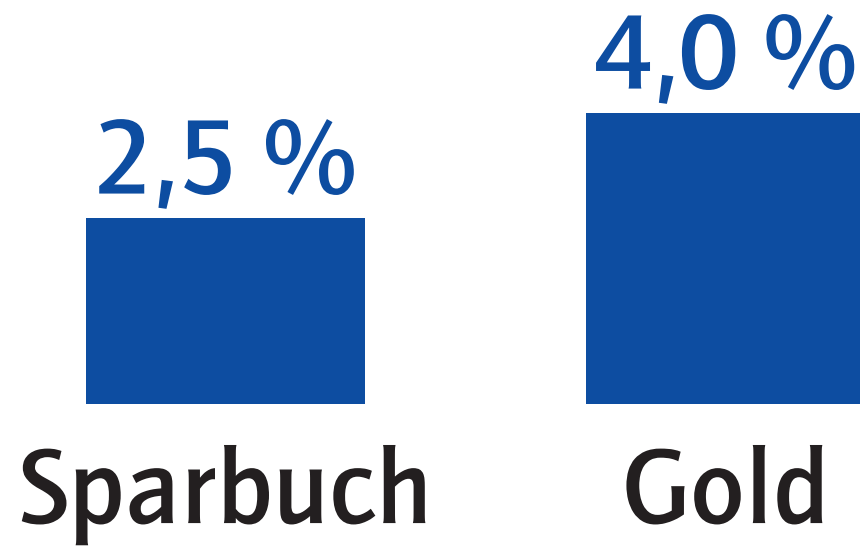

Erträge (Ø pro Jahr seit 1900)

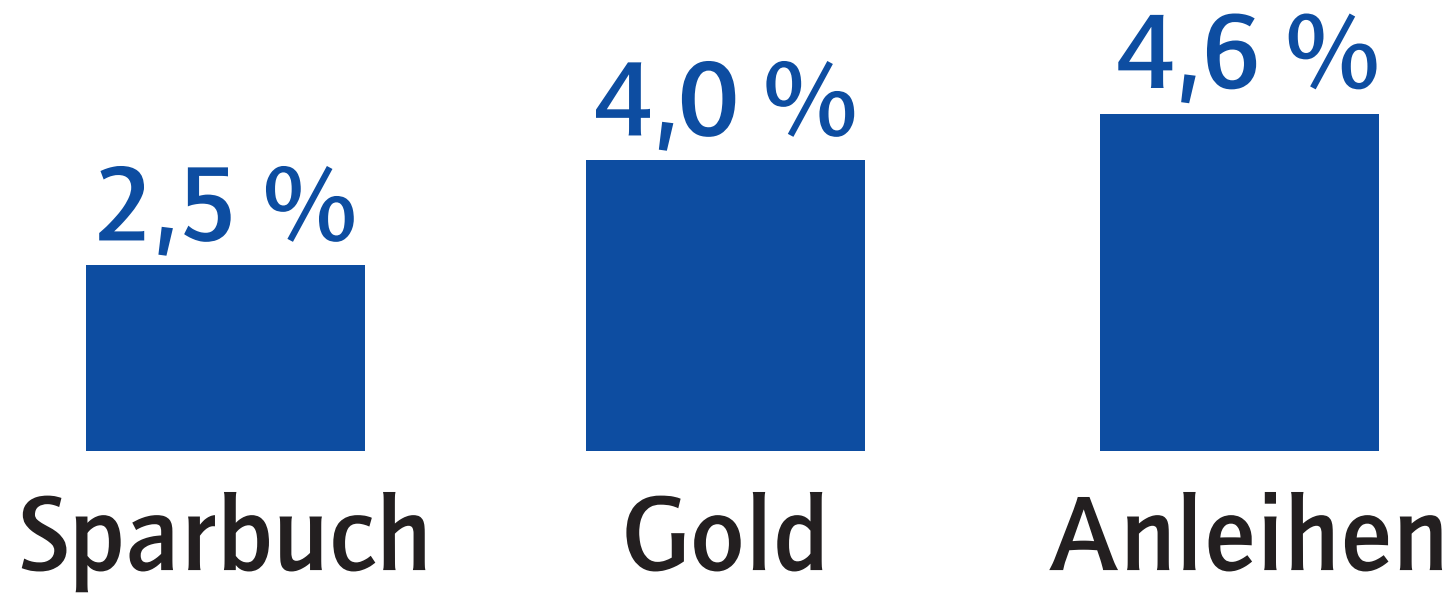

Erträge (Ø pro Jahr seit 1900)

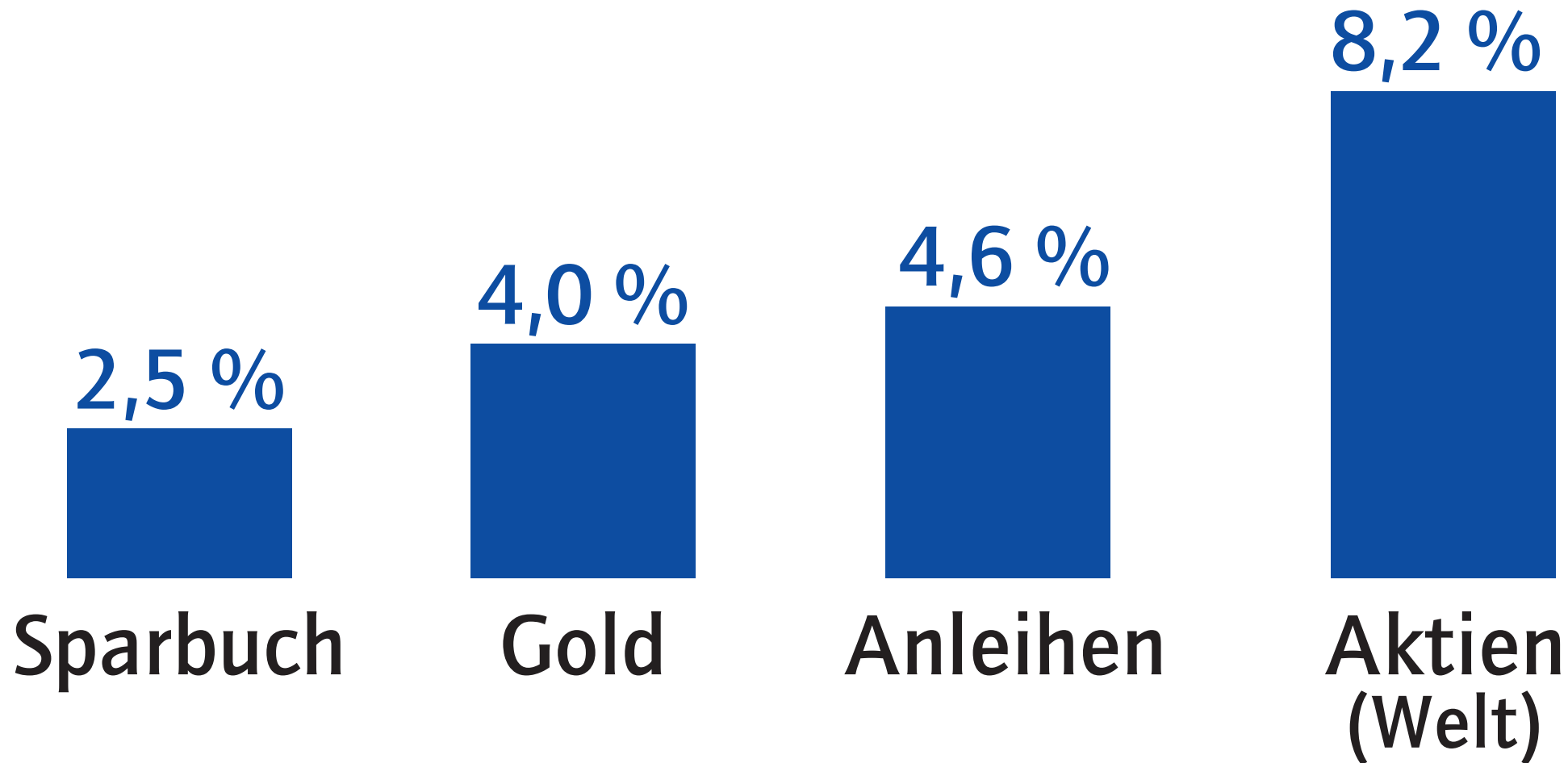

Erträge (Ø pro Jahr seit 1900)

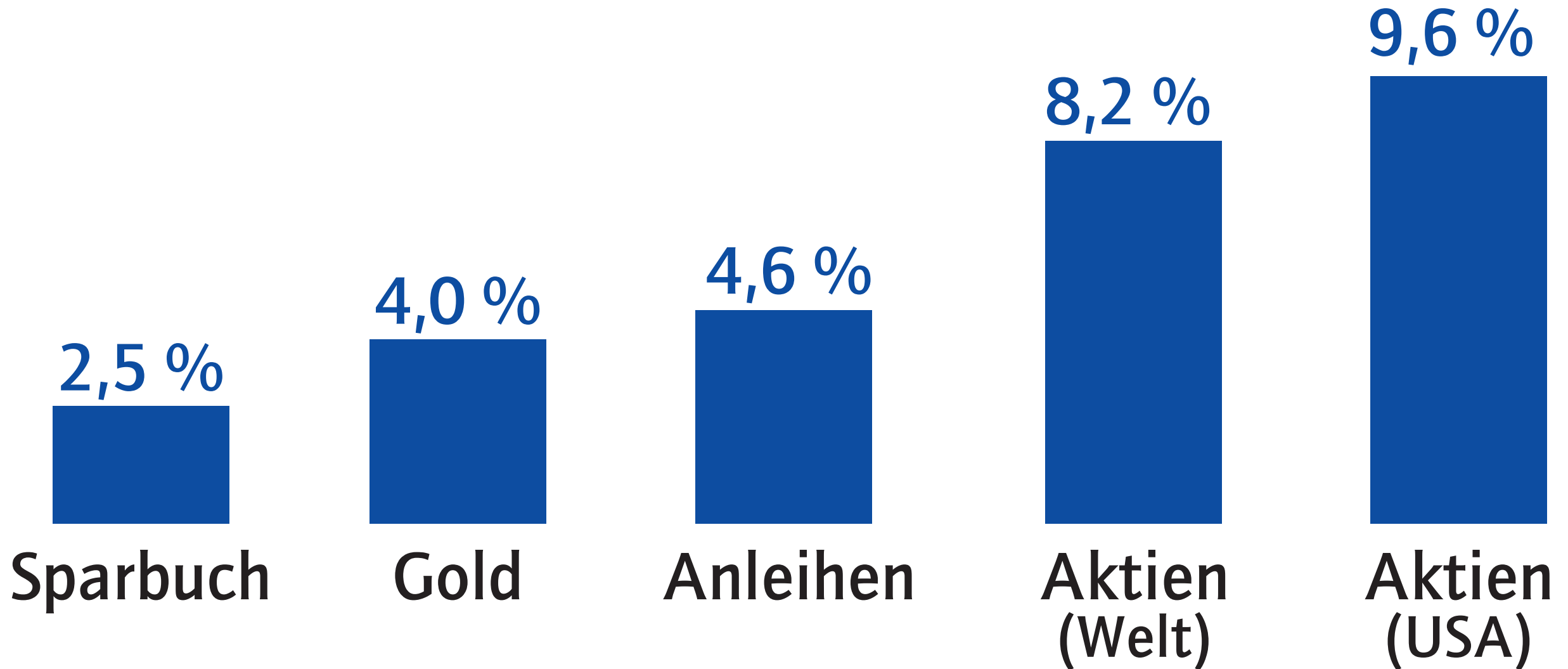



Inflation verringert den Ertrag

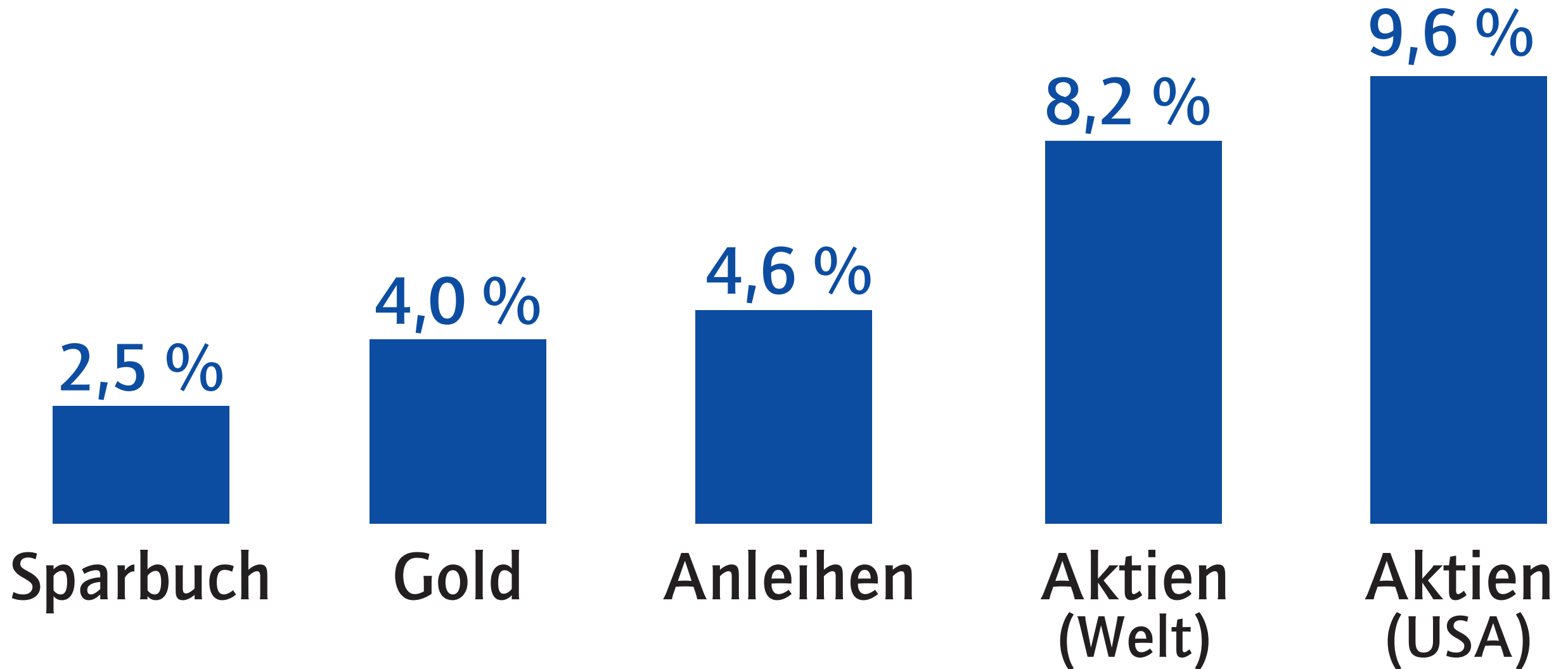



Inflation verringert den Ertrag

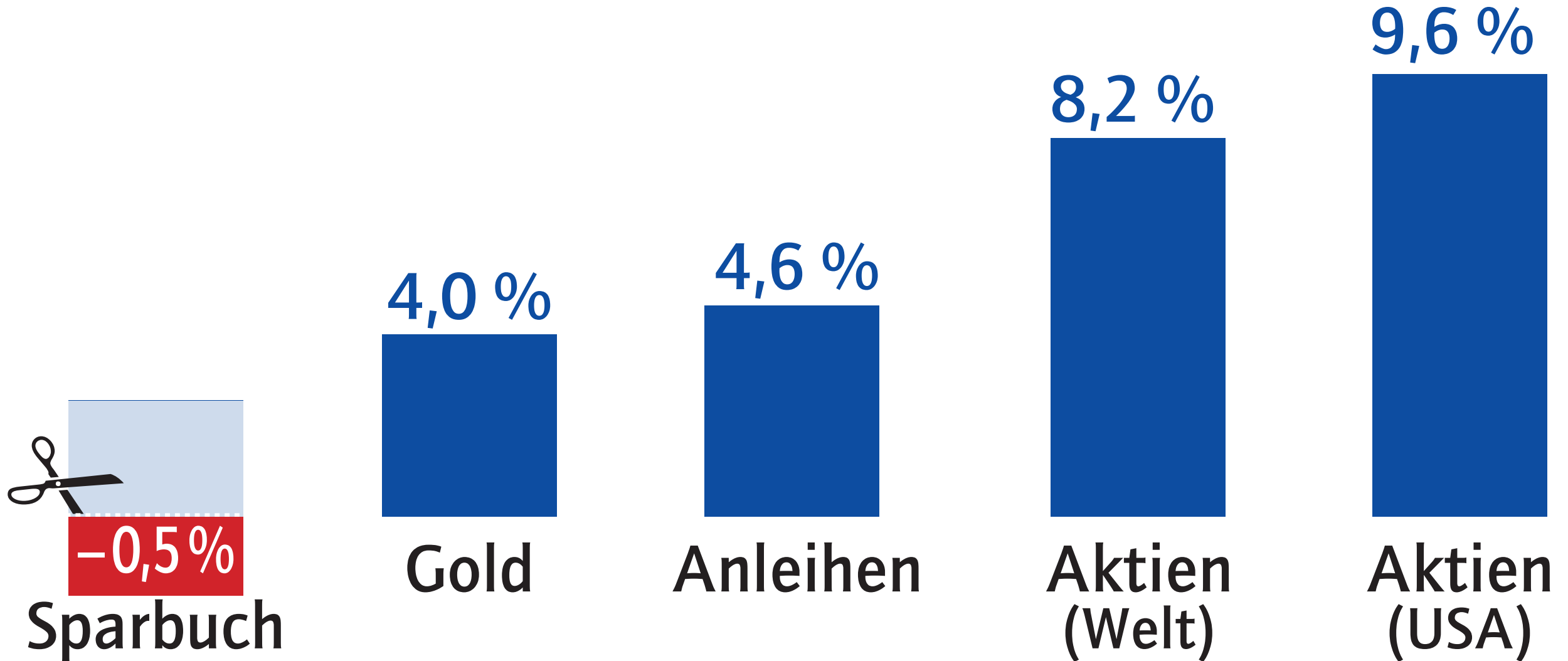



Inflation verringert den Ertrag

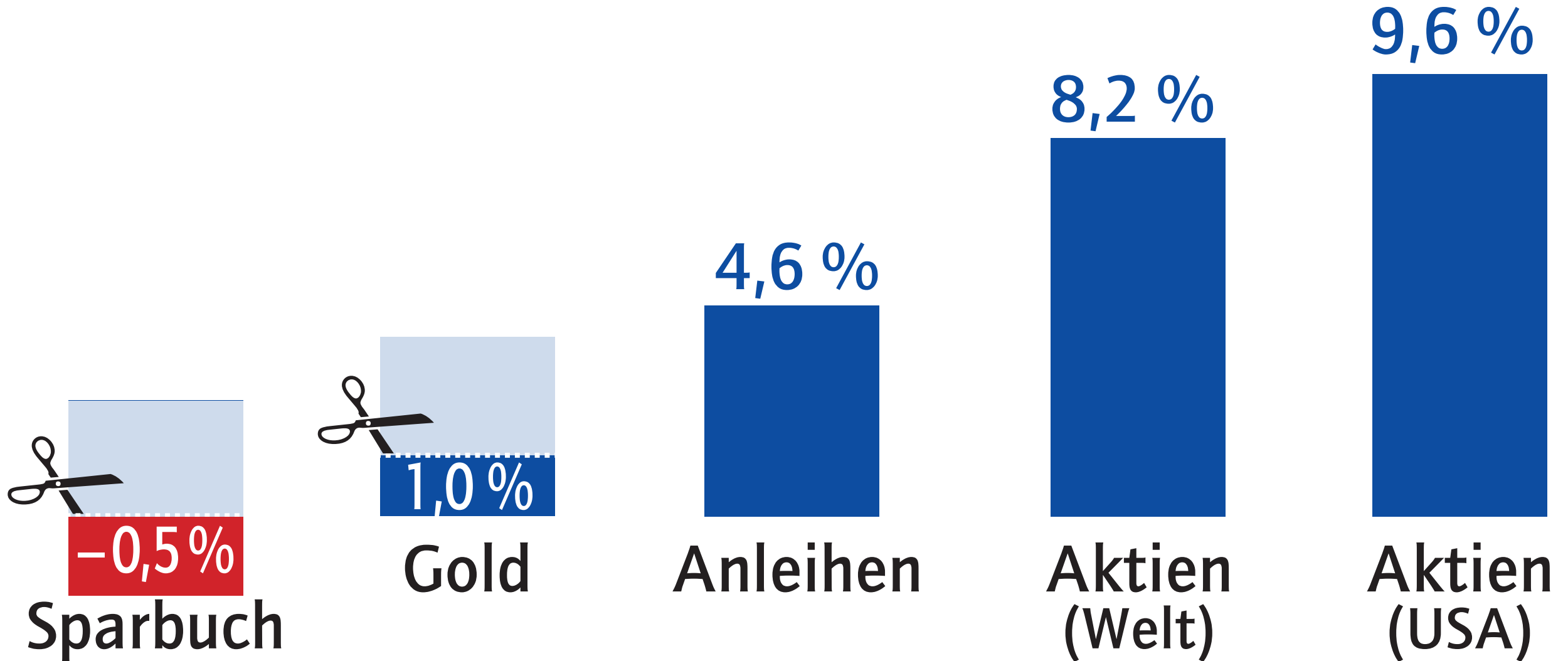



Inflation verringert den Ertrag

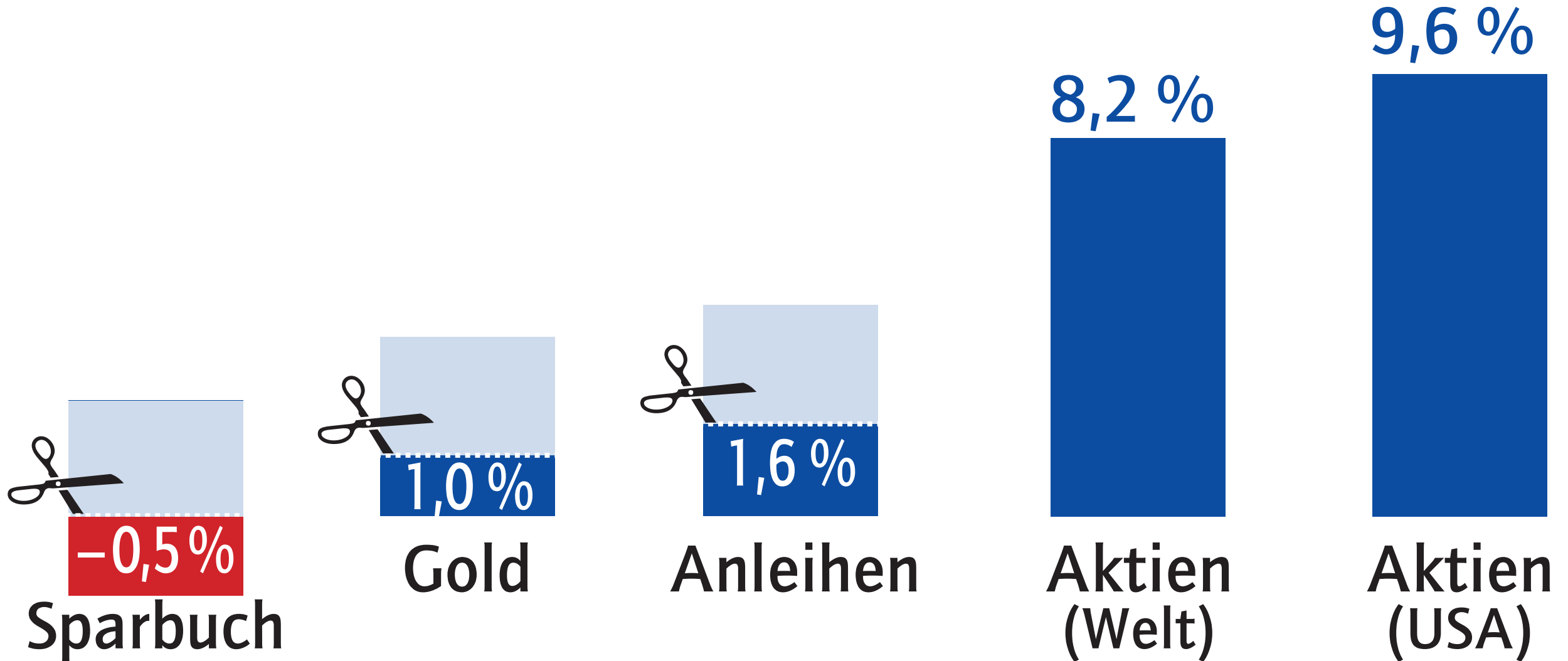



Inflation verringert den Ertrag

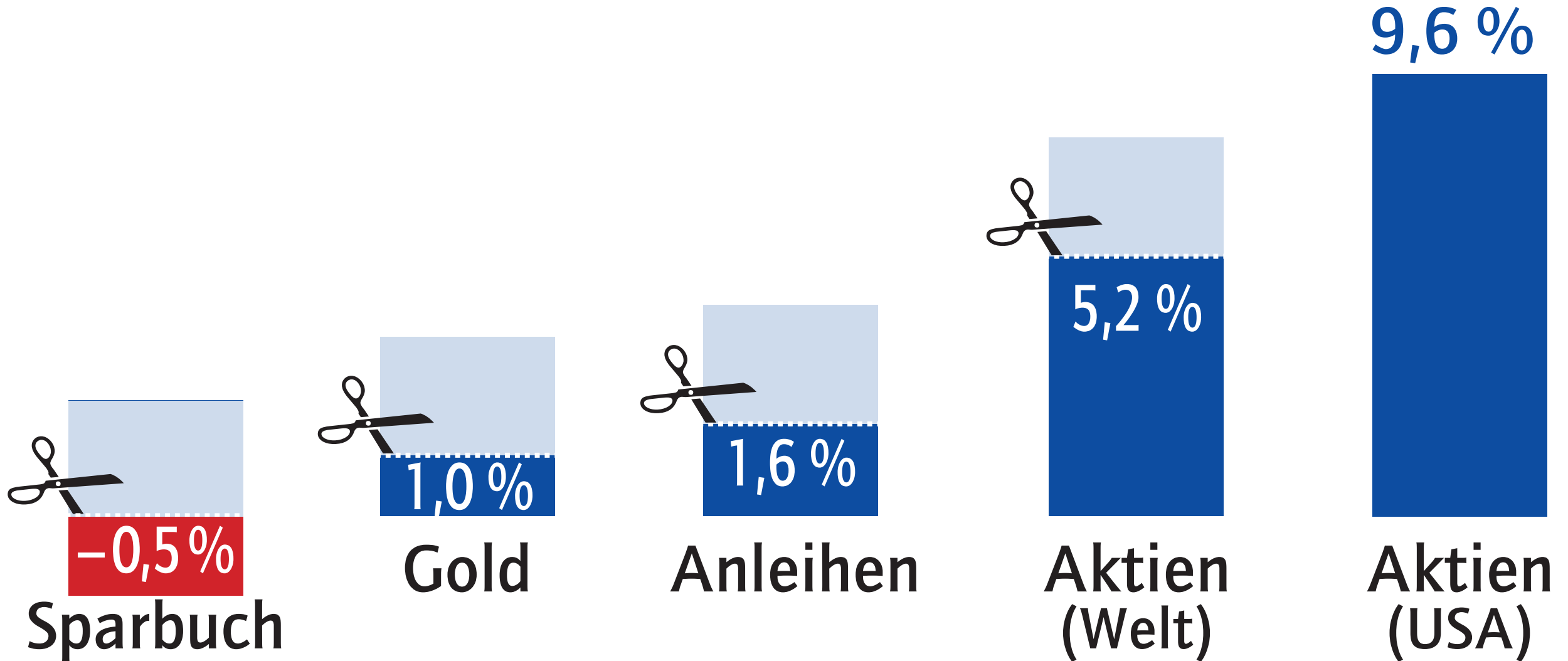



Inflation verringert den Ertrag

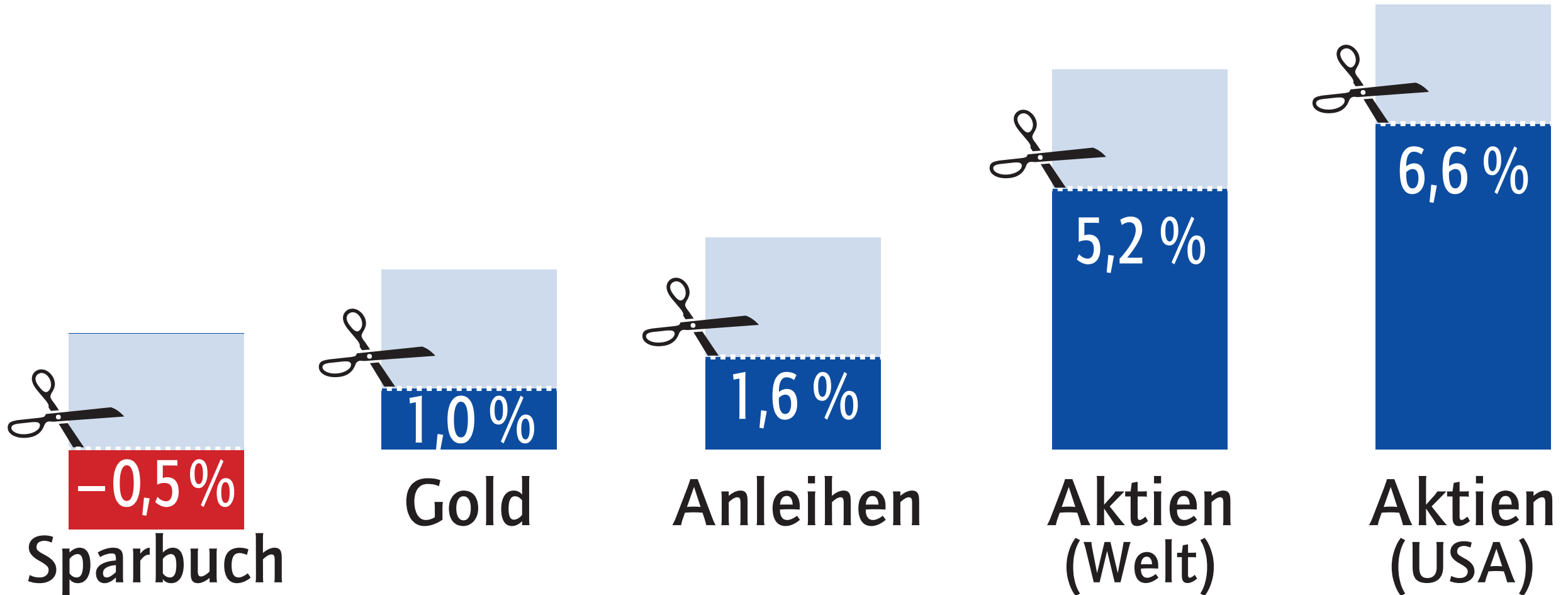

Alphabet



Gewinnmaschine Alphabet



2022

60 Mrd. \$

Gewinnmaschine Alphabet



2022

60 Mrd. \$



2023

74 Mrd. \$

Gewinnmaschine Alphabet



2022

60 Mrd. \$



2023

74 Mrd. \$



2024

95 Mrd. \$

Gewinnmaschine Alphabet



2022

60 Mrd. \$



2023

74 Mrd. \$



2024

95 Mrd. \$



2025

107 Mrd. \$

Alphabet





Becton Dickinson

USD

500

250

100

30

10

94

96

98

00

02

04

06

08

10

12

14

16

18

20

22

24

26

28

Bloomberg

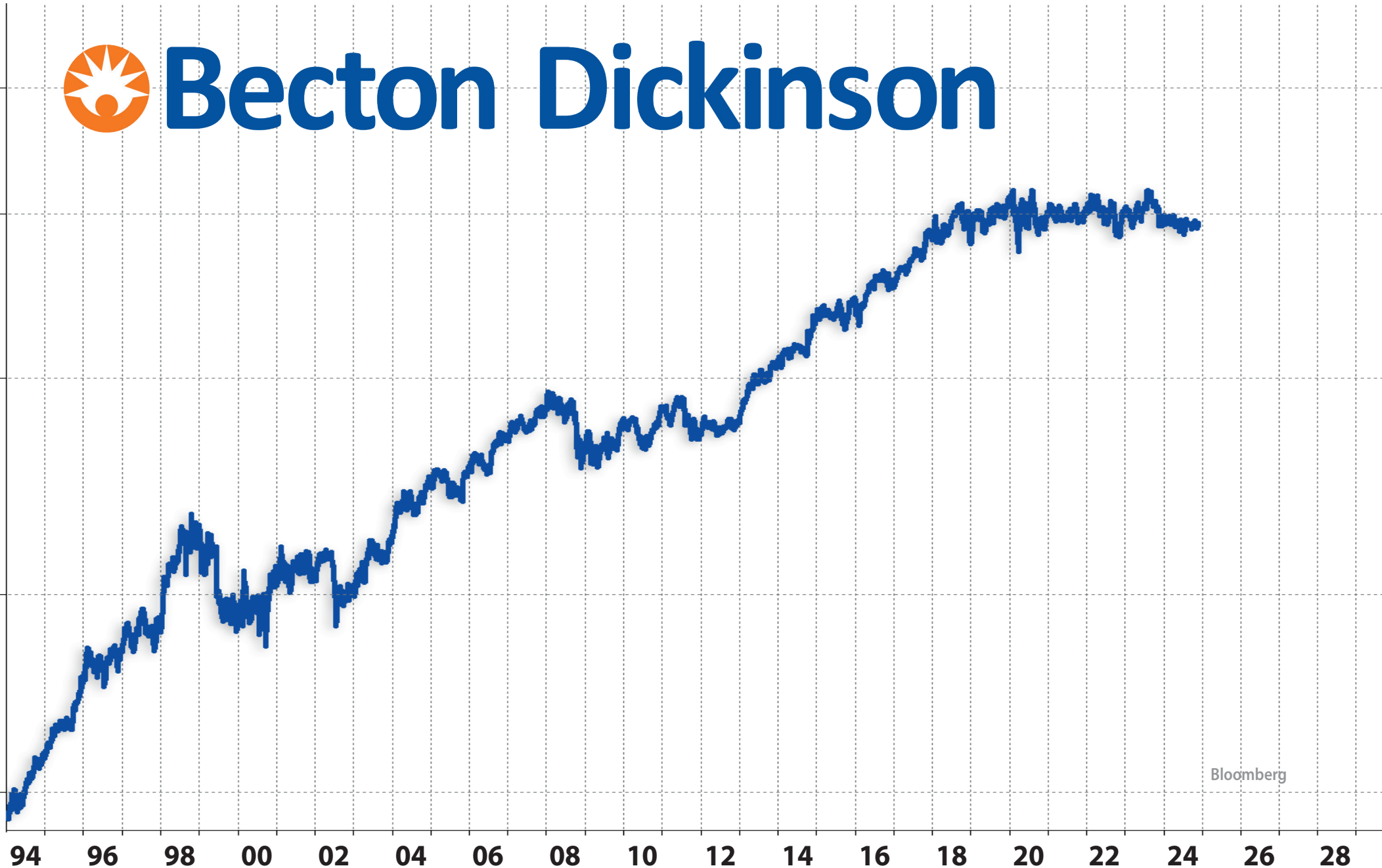



Becton Dickinson

USD

500

250

100

30

10

94

96

98

00

02

04

06

08

10

12

14

16

18

20

22

24

26

28



Bloomberg

Gewinnentwicklung Becton

(in Milliarden US-Dollar)

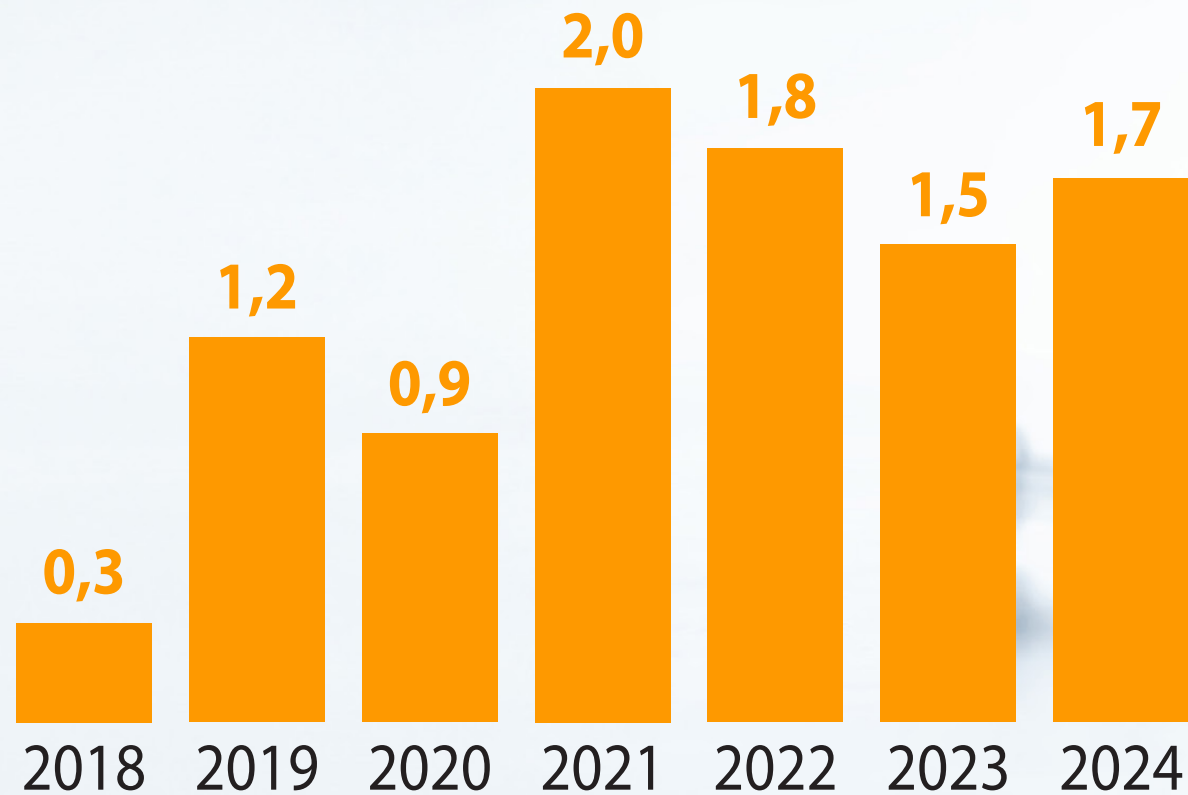

Gewinnentwicklung Becton

(in Milliarden US-Dollar)

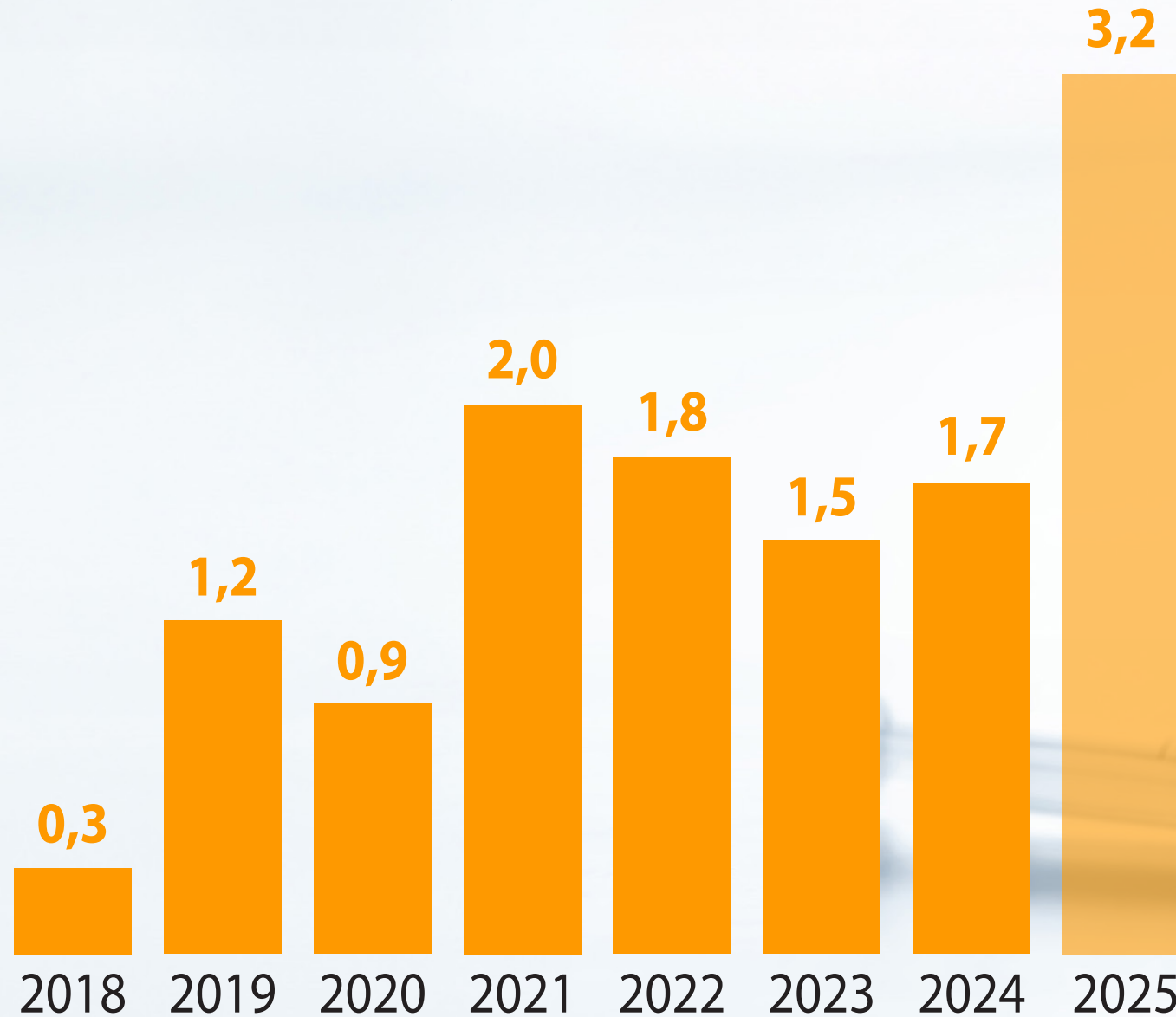

Gewinnentwicklung Becton

(in Milliarden US-Dollar)

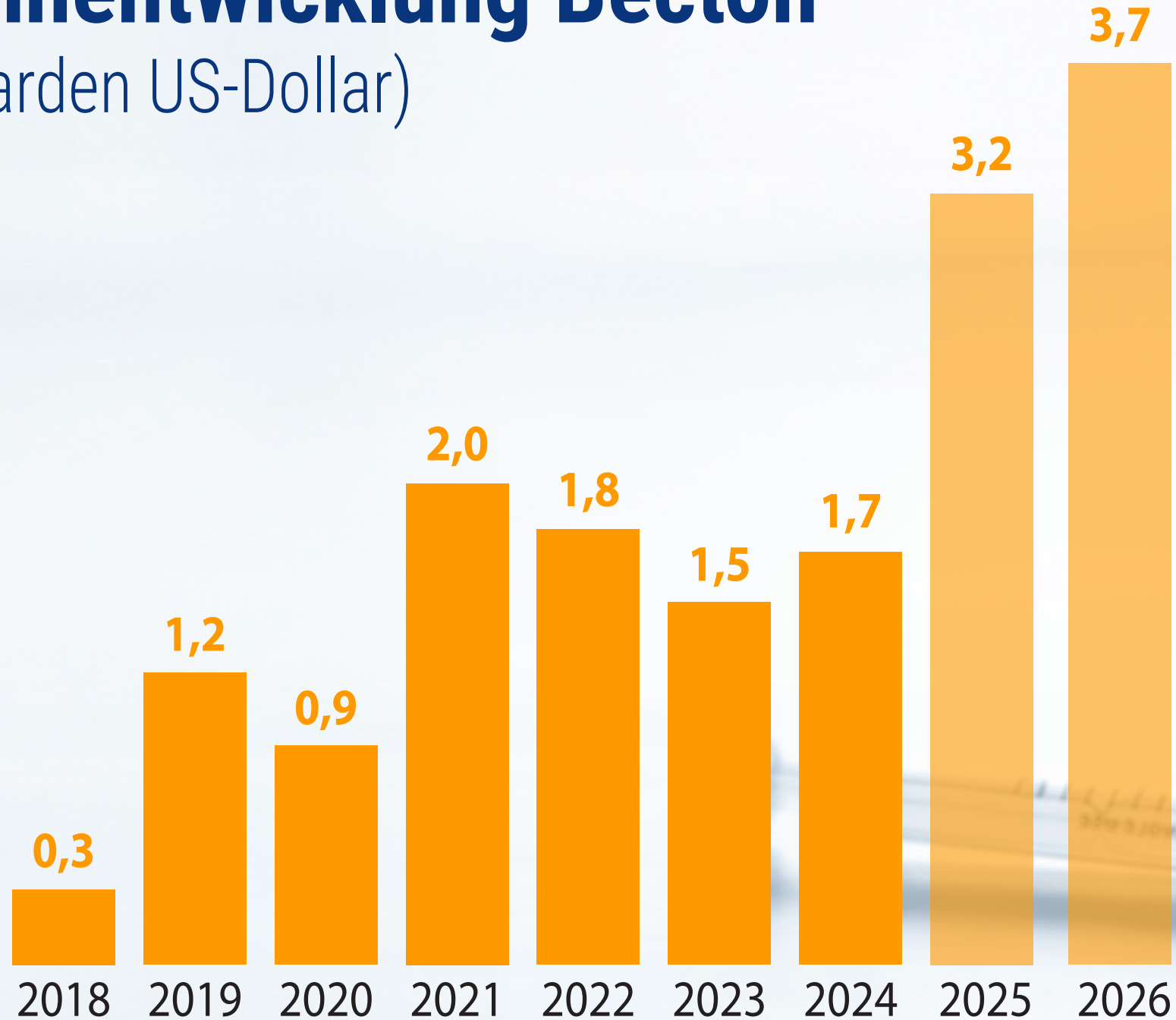

Gewinnentwicklung Becton

(in Milliarden US-Dollar)

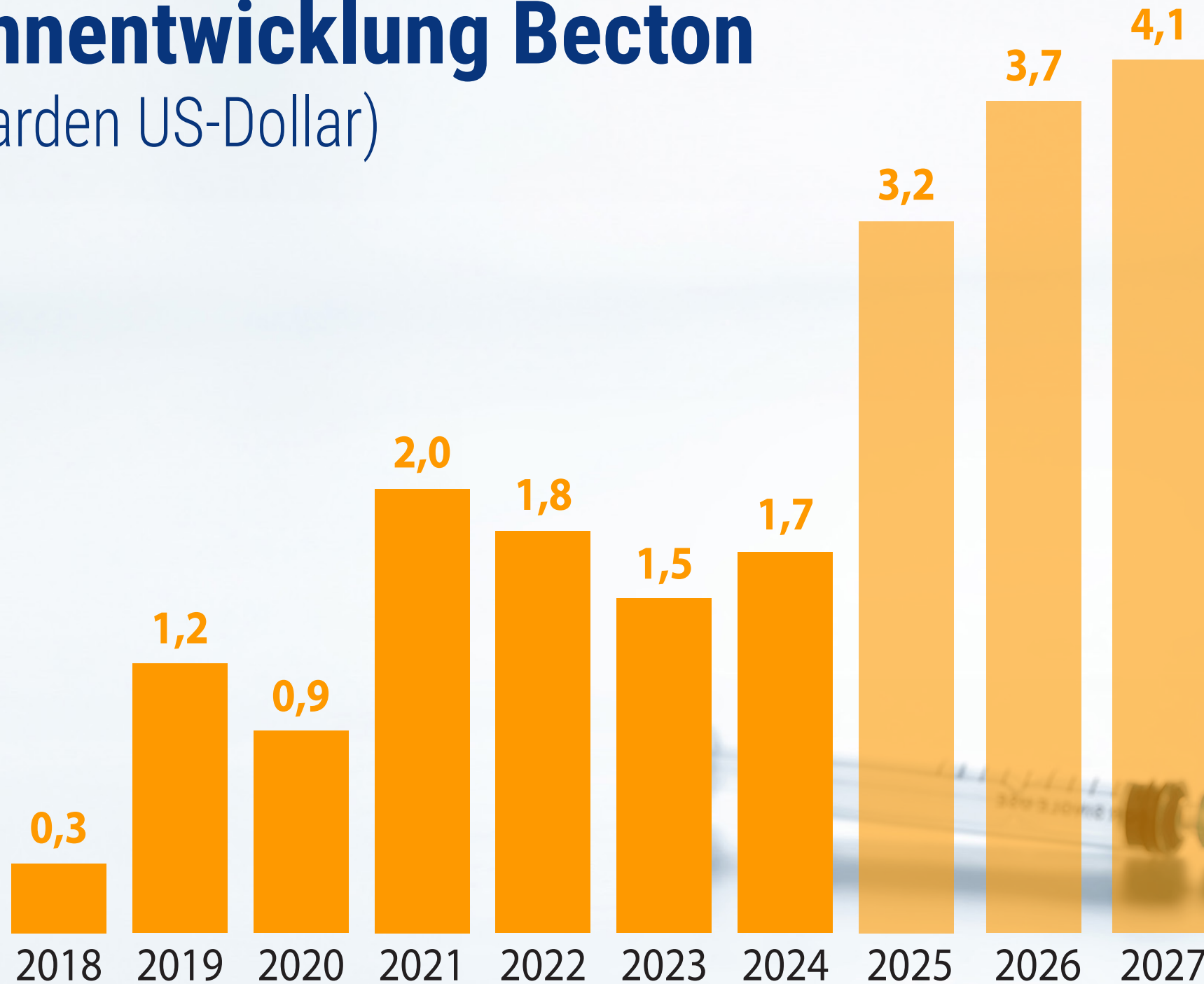



Becton Dickinson

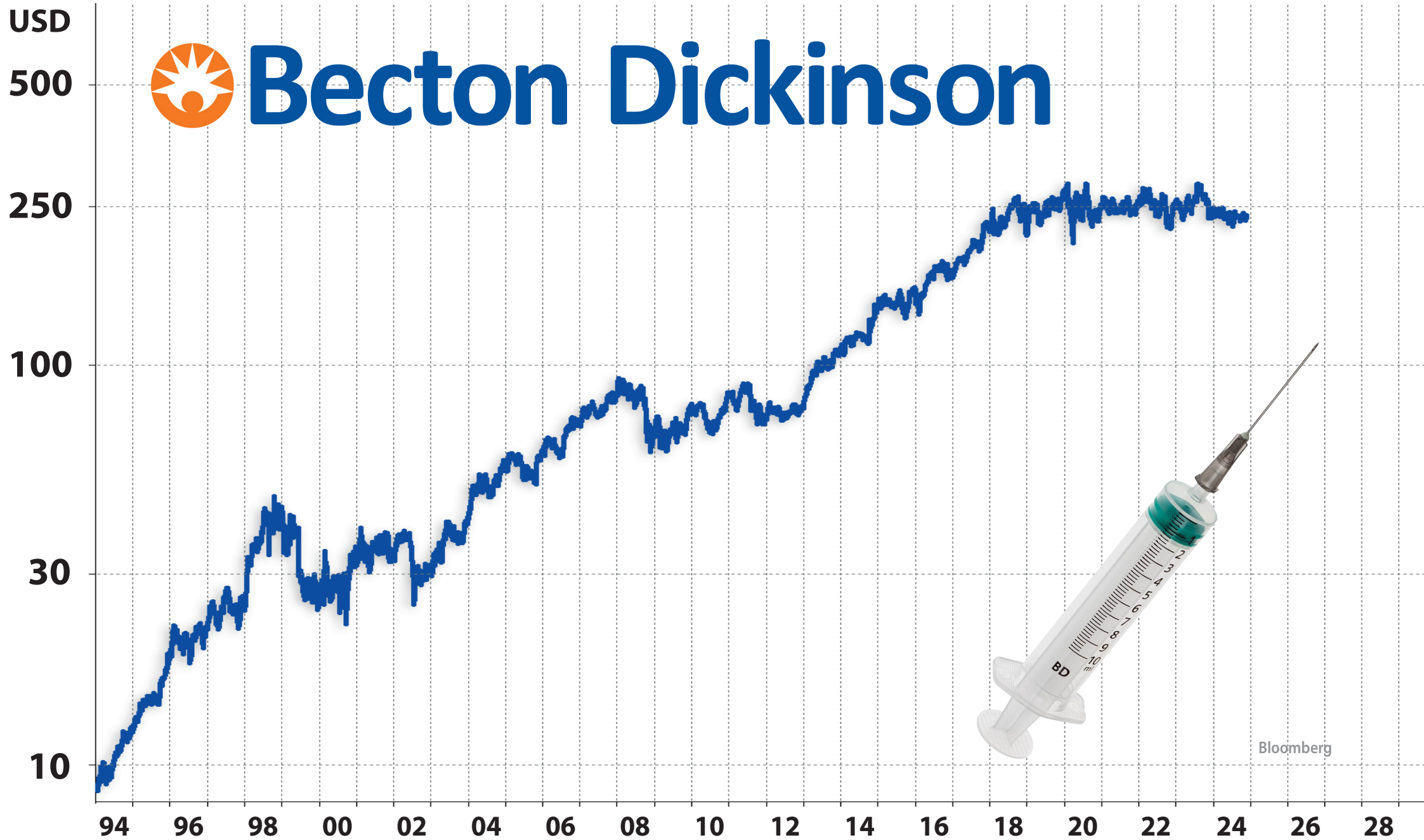

Bloomberg



danaher

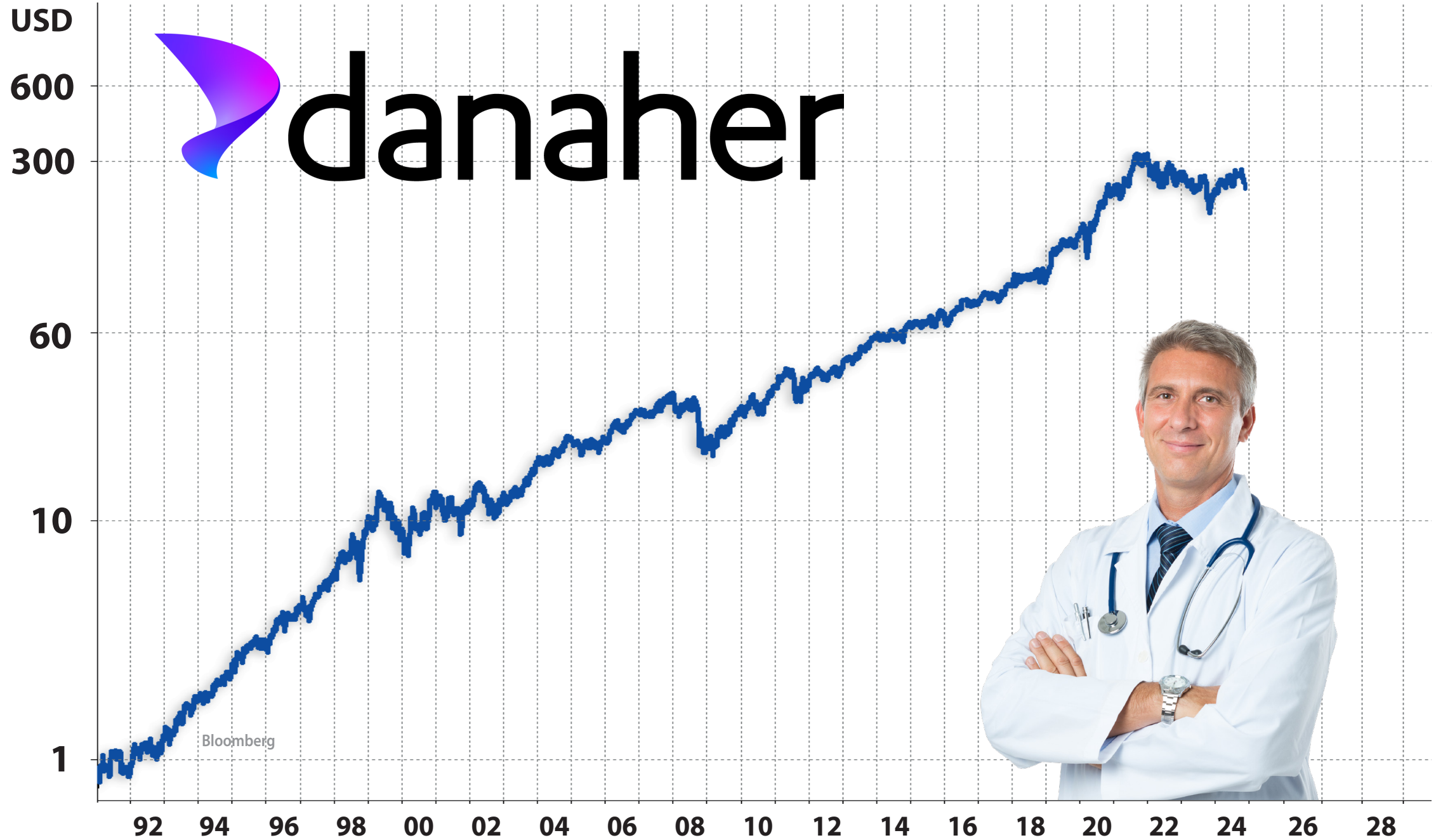

L'ORÉAL

EUR

800

330

200

50

14

92

94

96

98

00

02

04

06

08

10

12

14

16

18

20

22

24

26

28



Bloomberg

L'ORÉAL

EUR

800

330

200

50

14



EUR

L'ORÉAL

• von 14€ auf 330€

330

200

50

14



Bloomberg

EUR

L'ORÉAL

- von 14€ auf 330€
- 11% pro Jahr

330

200

50

14



Bloomberg

EUR

L'ORÉAL

- von 14€ auf 330€
- 11% pro Jahr
- + 2.300%

330

200

50

14



Bloomberg

EUR

L'ORÉAL

- von 14€ auf 330€
- 11% pro Jahr
- + 2.300%
- von 10.000€ auf 240.000€

330

200

50

14

92 94 96 98 00 02 04 06 08 10 12 14 16 18 20 22 24 26 28



Bloomberg

„Fall“-Beispiel

Aktie

L'ORÉAL

Aflac

 Air Liquide

Beiersdorf

COLGATE-PALMOLIVE

McDonald's

Medtronic

Microsoft

Nestlé

novo nordisk













„Fall“-Beispiel

Aktie	Wert vor 30 Jahren
L'ORÉAL	10.000 €
 Aflac	10.000 €
 Air Liquide	10.000 €
Beiersdorf	10.000 €
COLGATE-PALMOLIVE	10.000 €
McDonald's	10.000 €
Medtronic	10.000 €
Microsoft	10.000 €
Nestlé	10.000 €
novo nordisk	10.000 €

„Fall“-Beispiel

Aktie	Wert vor 30 Jahren		
L'ORÉAL	10.000 €	➔	240.000 €
Aflac	10.000 €		
Air Liquide	10.000 €		
Beiersdorf	10.000 €		
COLGATE-PALMOLIVE	10.000 €		
McDonald's	10.000 €		
Medtronic	10.000 €		
Microsoft	10.000 €		
Nestlé	10.000 €		
novo nordisk	10.000 €		

„Fall“-Beispiel

Aktie	Wert vor 30 Jahren	heute	
L'ORÉAL	10.000 €		240.000 €
 Aflac	10.000 €		0 € Totalverlust
 Air Liquide	10.000 €		0 € Totalverlust
Beiersdorf	10.000 €		0 € Totalverlust
COLGATE-PALMOLIVE	10.000 €		0 € Totalverlust
McDonald's	10.000 €		0 € Totalverlust
Medtronic	10.000 €		0 € Totalverlust
Microsoft	10.000 €		0 € Totalverlust
Nestlé	10.000 €		0 € Totalverlust
novo nordisk	10.000 €		0 € Totalverlust
Depotwert	100.000 €		

„Fall“-Beispiel

Aktie	Wert vor 30 Jahren		heute	
L'ORÉAL	10.000 €	➡	240.000 €	
Aflac	10.000 €	➡	0 €	Totalverlust
Air Liquide	10.000 €	➡	0 €	Totalverlust
Beiersdorf	10.000 €	➡	0 €	Totalverlust
COLGATE-PALMOLIVE	10.000 €	➡	0 €	Totalverlust
McDonald's	10.000 €	➡	0 €	Totalverlust
Medtronic	10.000 €	➡	0 €	Totalverlust
Microsoft	10.000 €	➡	0 €	Totalverlust
Nestlé	10.000 €	➡	0 €	Totalverlust
novo nordisk	10.000 €	➡	0 €	Totalverlust
Depotwert	100.000 €	➡	240.000 €	

Christoph Wendling beim Schulvortrag in Stuttgart



Aktien für die Langfristanlage

Alphabet

Internet

USA

WKN **A14 Y6F**

 **Becton**

Medizintechnik

USA

WKN **857 675**

 **danaher**

Gesundheit

USA

WKN **866 197**

L'ORÉAL

Kosmetik

FRA

WKN **853 888**

***„Warten Sie nicht,
um Aktien zu kaufen.“***

***„Warten Sie nicht,
um Aktien zu kaufen.***

***Kaufen Sie Aktien,
und warten Sie dann.“***

Was bei der Dividende wirklich wichtig ist



Dieter Beck

108.493

108.493

Dow Jones

43.0000

108.493

Dow Jones

43.000

(Ohne Dividende)

(Mit Dividende)

108.493

Dow Jones

43.000

(Ohne Dividende)

Wo gibt's die höchste Dividende?

6%

5%

3%

2%

4%



Wo gibt's die höchste Dividende?

6%

5%

3%

2%

4%

26%





Türkische Lira

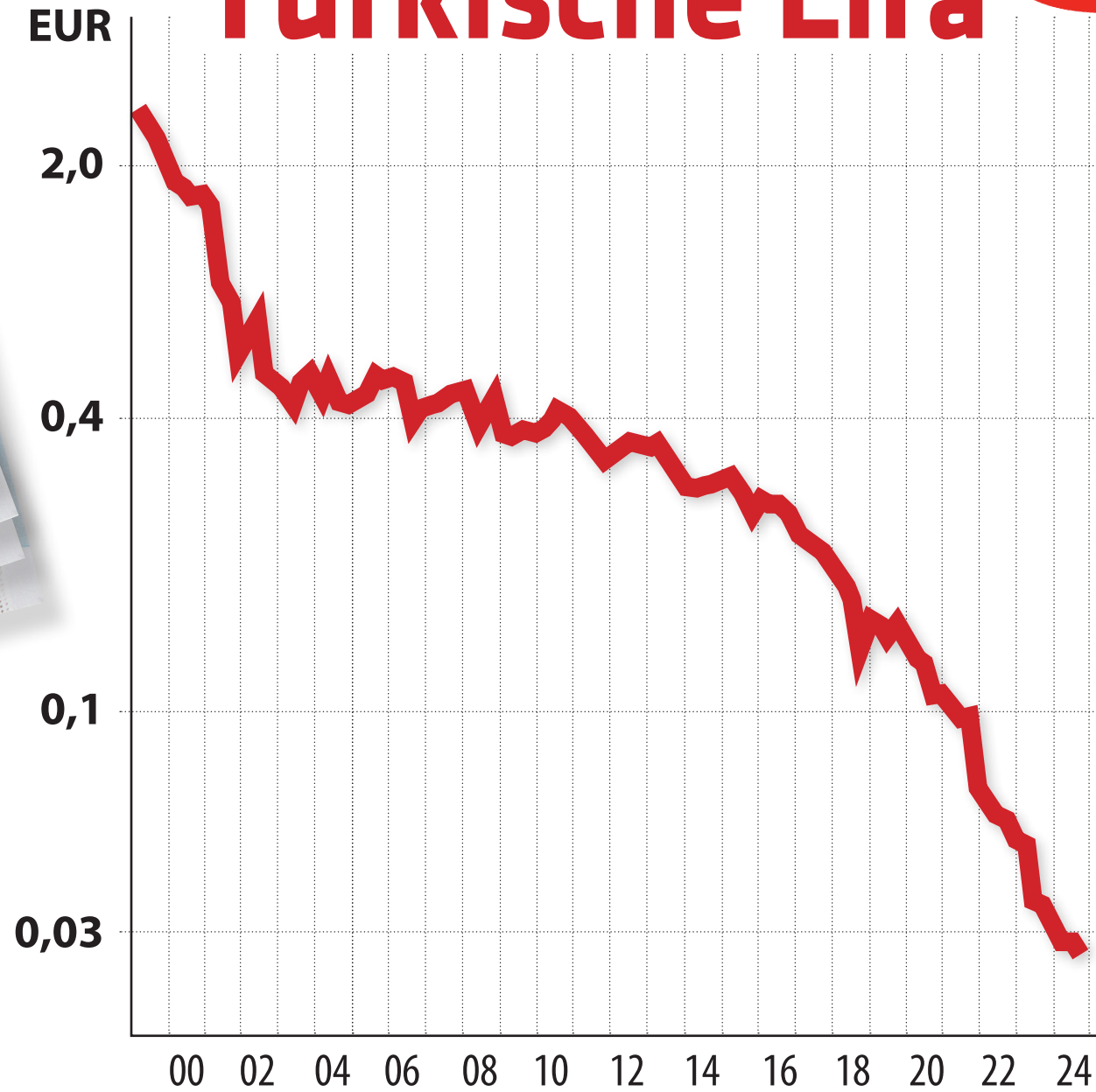

Was bei der Dividende wichtig ist:

Was bei der Dividende wichtig ist:

- **Die Höhe**

AUD

BHP

50

20

5

1

84 86 88 90 92 94 96 98 00 02 04 06 08 10 12 14 16 18 20 22 24 26



Bloomberg

AUD

BHP

50

20

5

1

6 % Dividende

84 86 88 90 92 94 96 98 00 02 04 06 08 10 12 14 16 18 20 22 24 26



Bloomberg

Was bei der Dividende wichtig ist:

- **Die Höhe**

Was bei der Dividende wichtig ist:

- **Die Höhe**
- **Die Kontinuität**

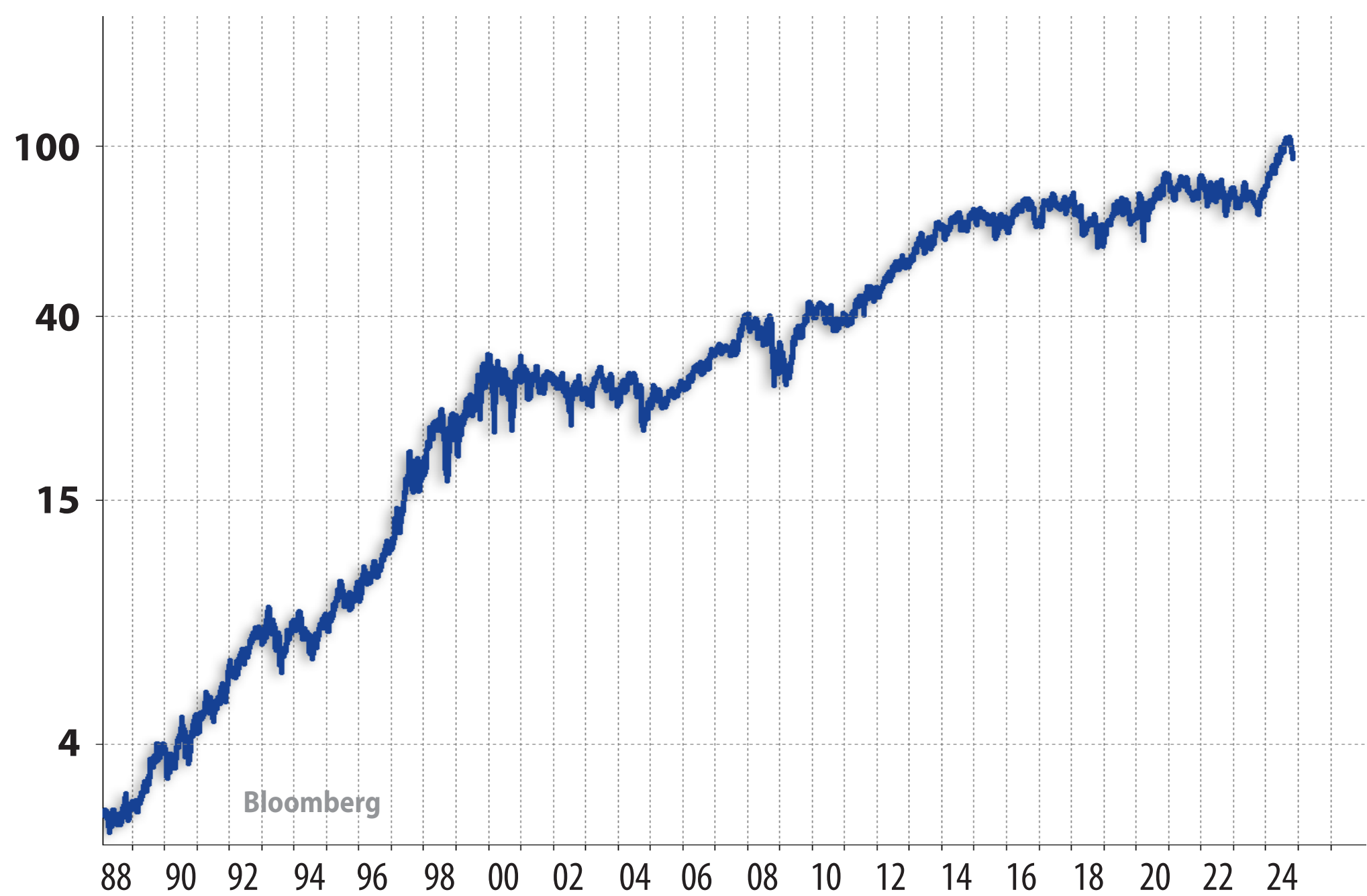

Bloomberg

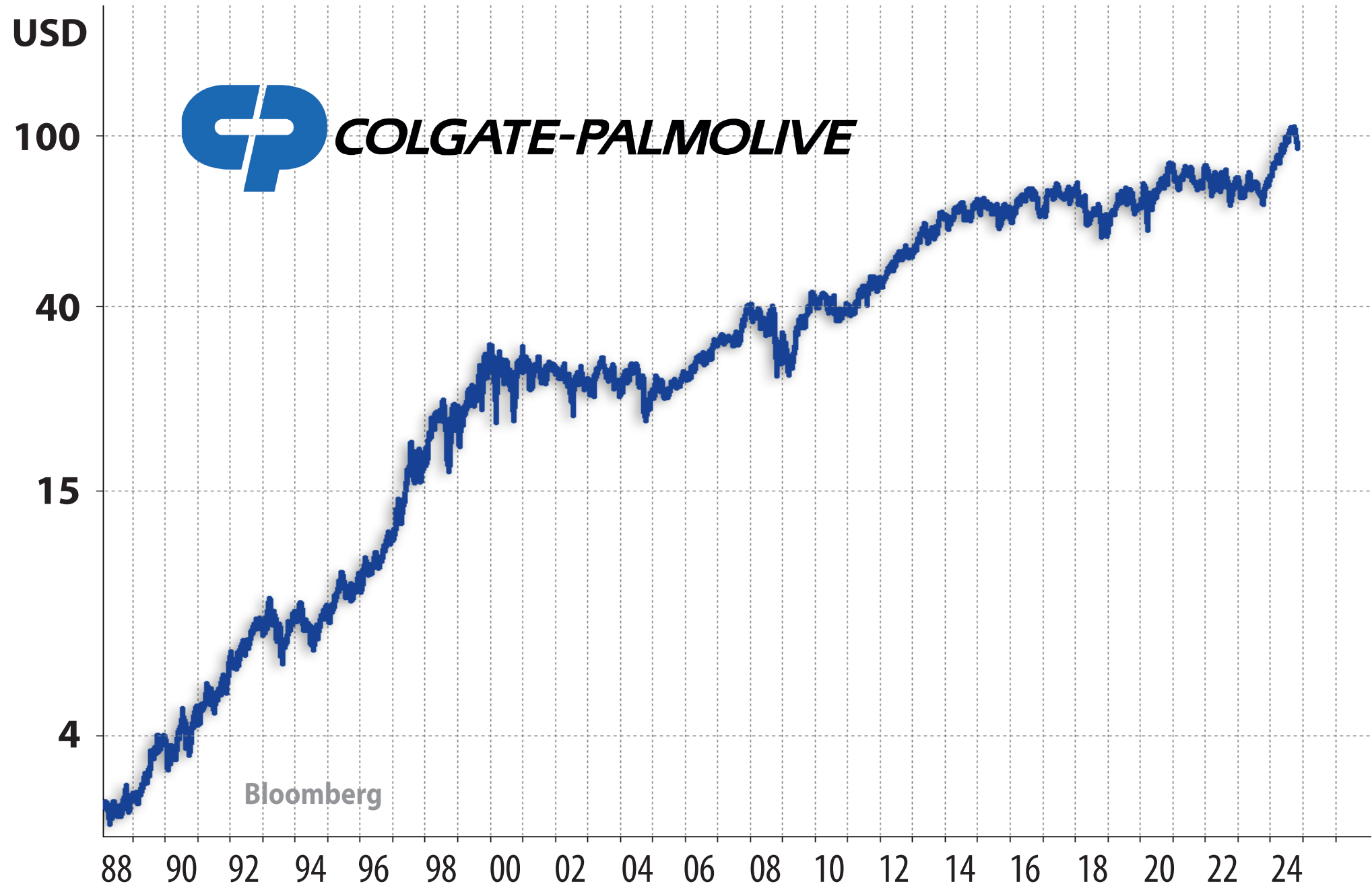

USD



COLGATE-PALMOLIVE

100

40

15

4

88

90

92

94

96

98

00

02

04

06

08

10

12

14

16

18

20

22

24

Bloomberg

zahlt seit 1895!

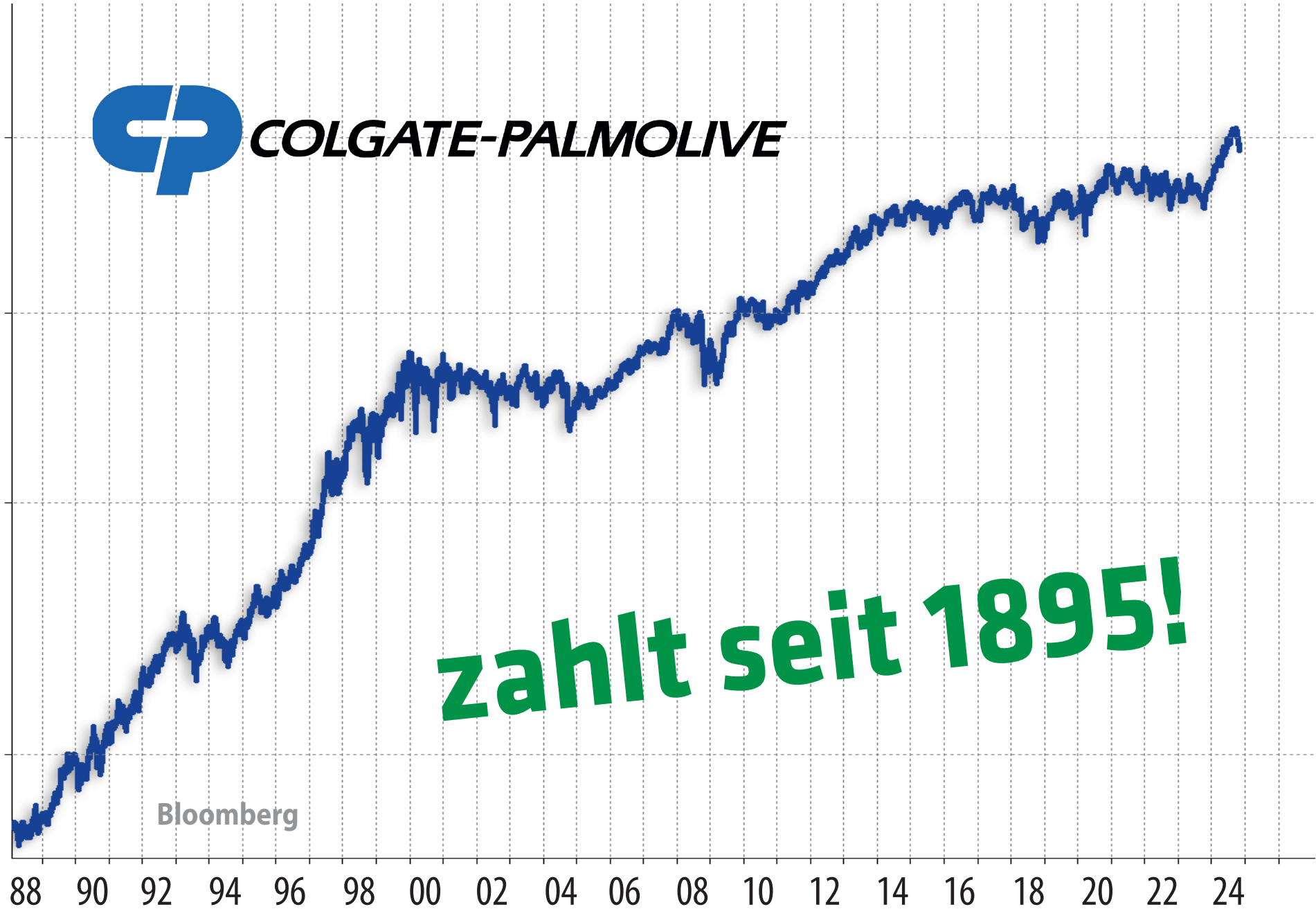

Was bei der Dividende wichtig ist:

- **Die Höhe**
- **Die Kontinuität**

Was bei der Dividende wichtig ist:

- **Die Höhe**
- **Die Kontinuität**
- **Die Steigerung**

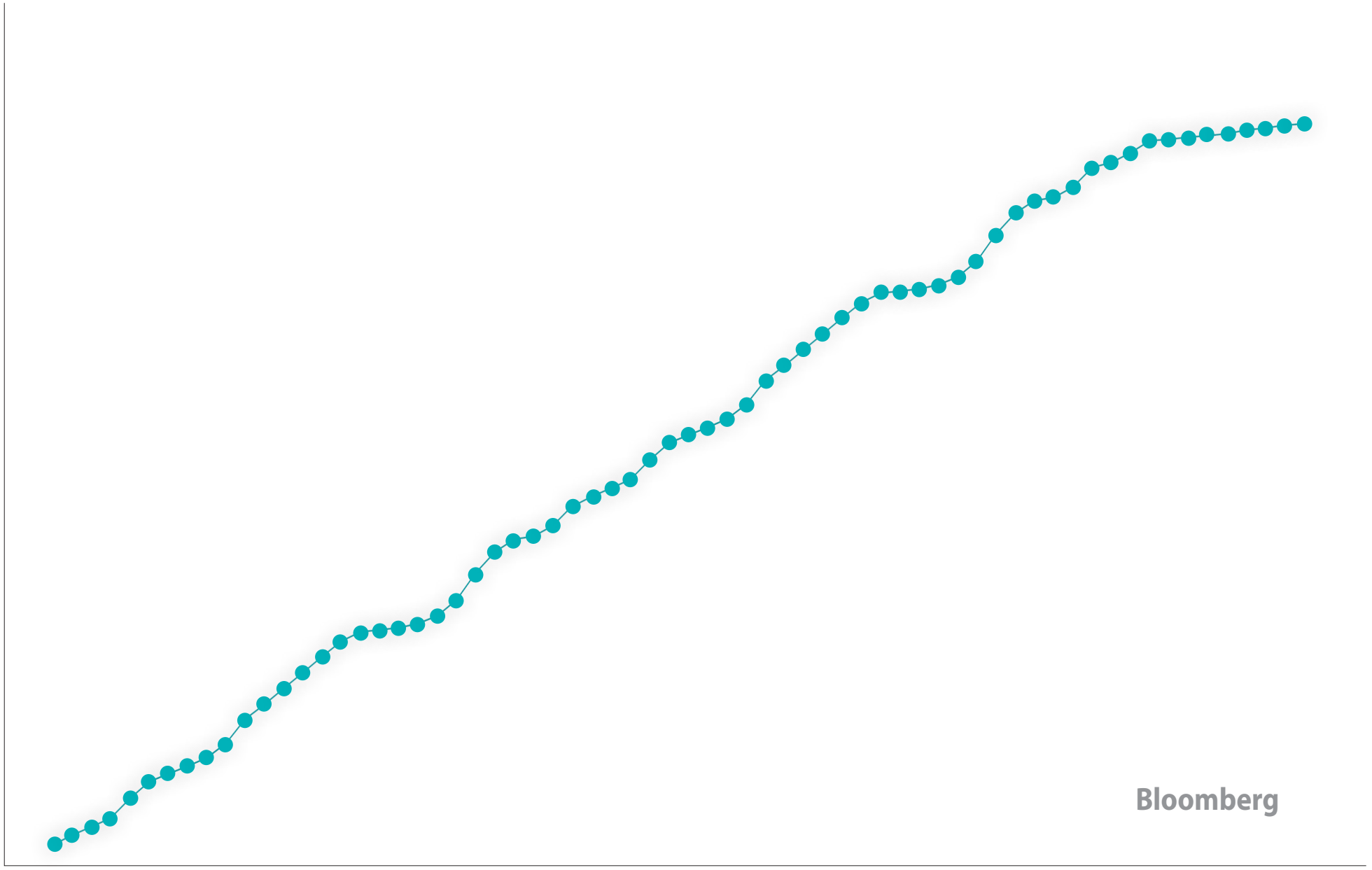

1957 - 2024

Bloomberg



EMERSON

seit 68 Jahren steigt
die Dividende!



Bloomberg

1957 - 2024

USD

EMERSON

110

50

20

8

90 92 94 96 98 00 02 04 06 08 10 12 14 16 18 20 22 24



Bloomberg

Was bei der Dividende wichtig ist:

- **Die Höhe**
- **Die Kontinuität**
- **Die Steigerung**

Was bei der Dividende wichtig ist:

- **Die Höhe**
- **Die Kontinuität**
- **Die Steigerung**
- **Die DSR**

Was bei der Dividende wichtig ist:

- **Die Höhe**
- **Die Kontinuität**
- **Die Steigerung**
- **Die DSR (Dividenden Steigerungs Rate)**

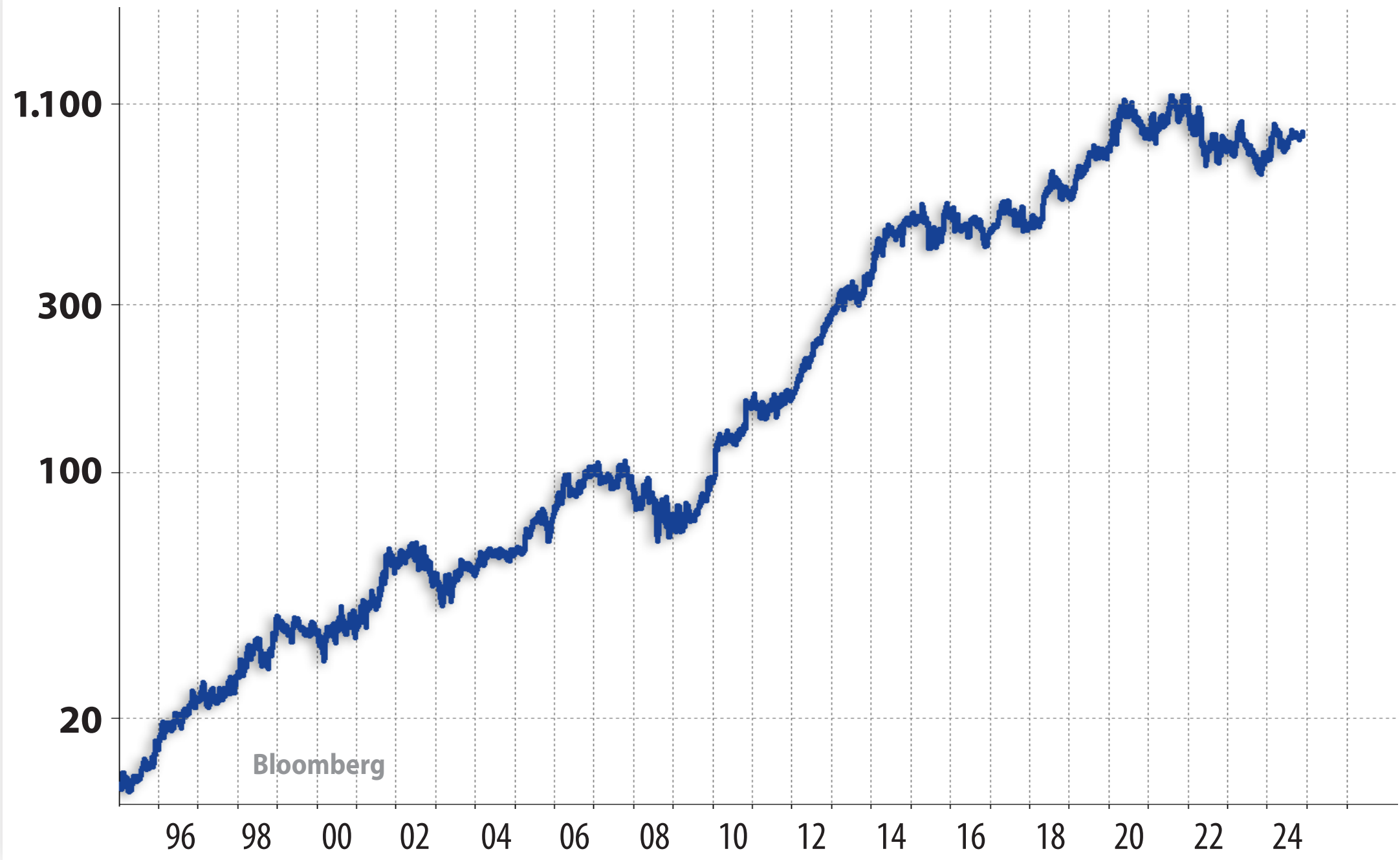

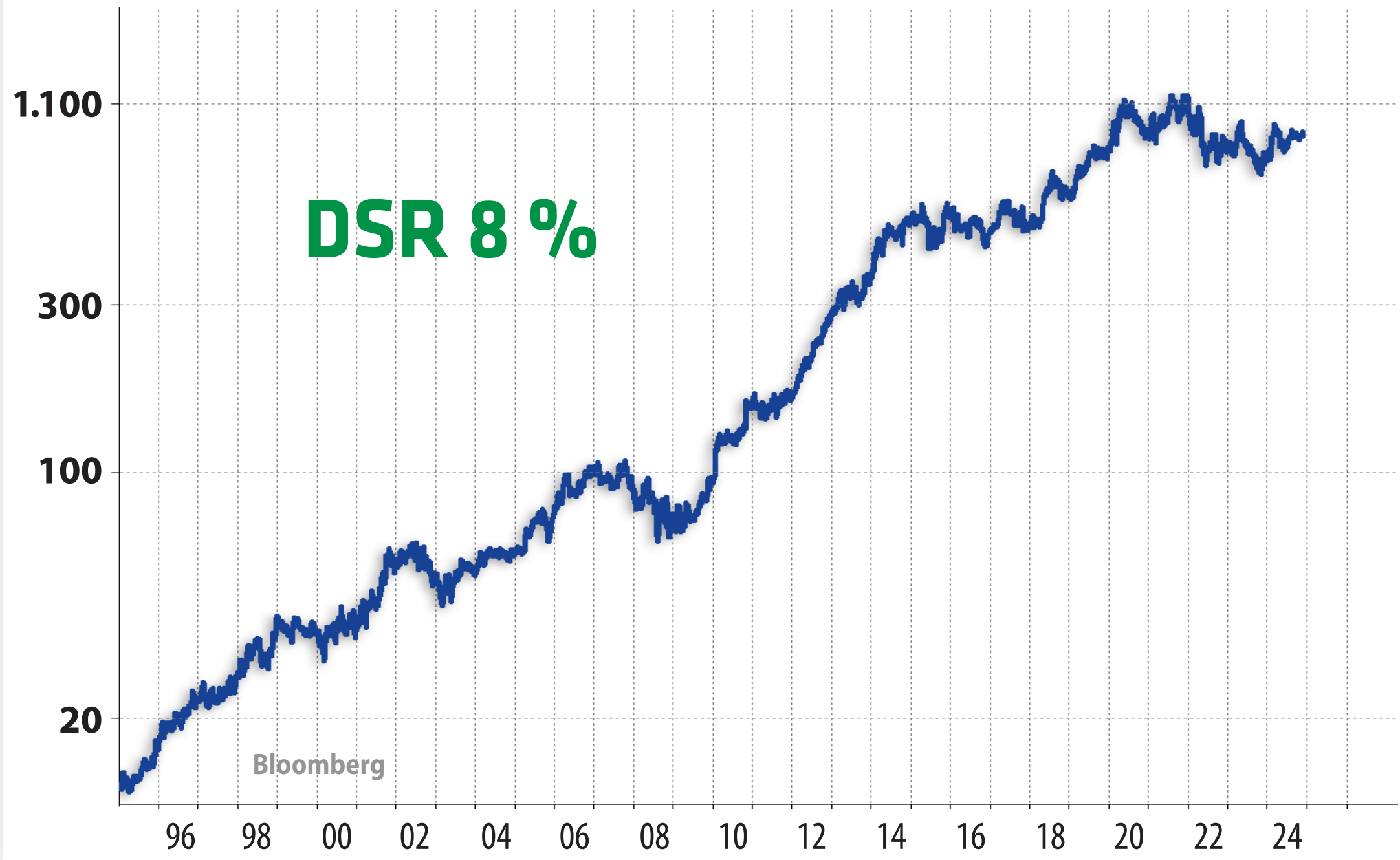

DSR 8 %

Bloomberg

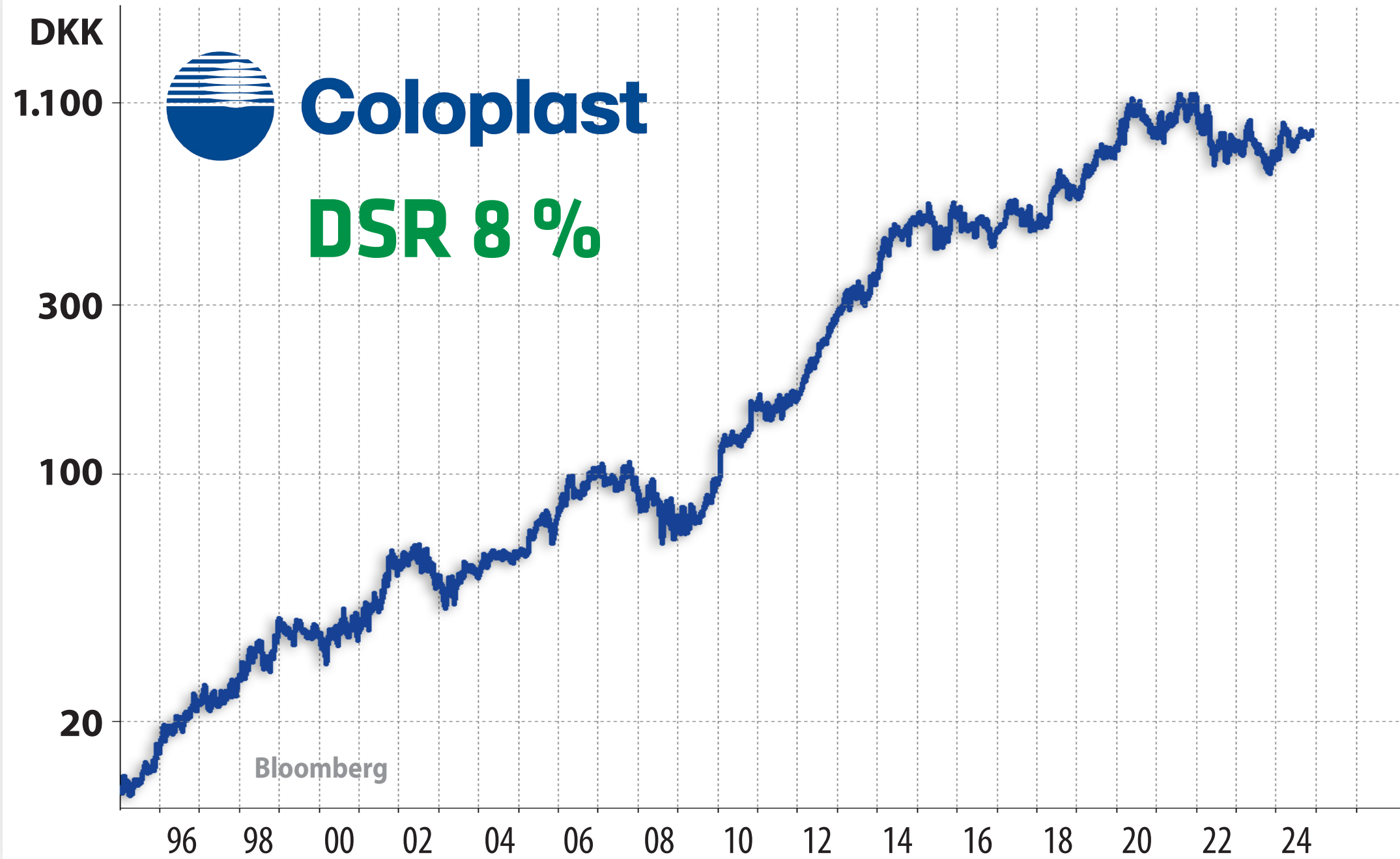

Was bei der Dividende wichtig ist:

- **Die Höhe**
- **Die Kontinuität**
- **Die Steigerung**
- **Die DSR (Dividenden Steigerungs Rate)**

Was bei der Dividende wichtig ist:

- Die Höhe
- Die Kontinuität
- Die Steigerung
- Die DSR (Dividenden Steigerungs Rate)
- Die PDR

Was bei der Dividende wichtig ist:

- **Die Höhe**
- **Die Kontinuität**
- **Die Steigerung**
- **Die DSR (Dividenden Steigerungs Rate)**
- **Die PDR (Persönliche Dividenden Rendite)**

ORACLE

USD

140

70

30

10

04

06

08

10

12

14

16

18

20

22

24

Bloomberg



ORACLE

**Dividendenrendite
1,1 Prozent**

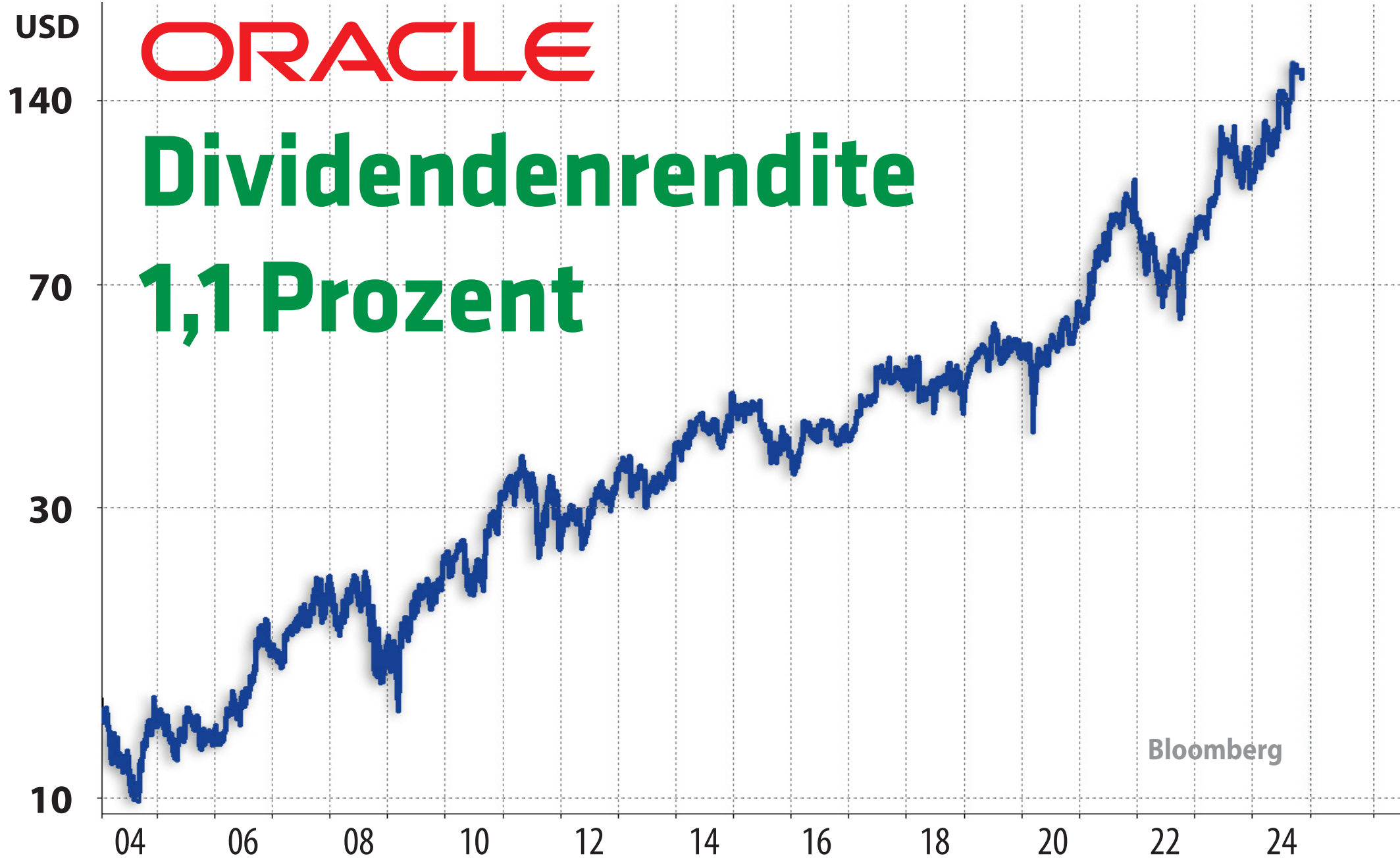

ORACLE

2009: Investition 10.000 Dollar

USD

140

70

30

10

04

06

08

10

12

14

16

18

20

22

24

Bloomberg



ORACLE

2009: Investition 10.000 Dollar
2009: Dividende 110 Dollar
Dividendenrendite 1,1 %

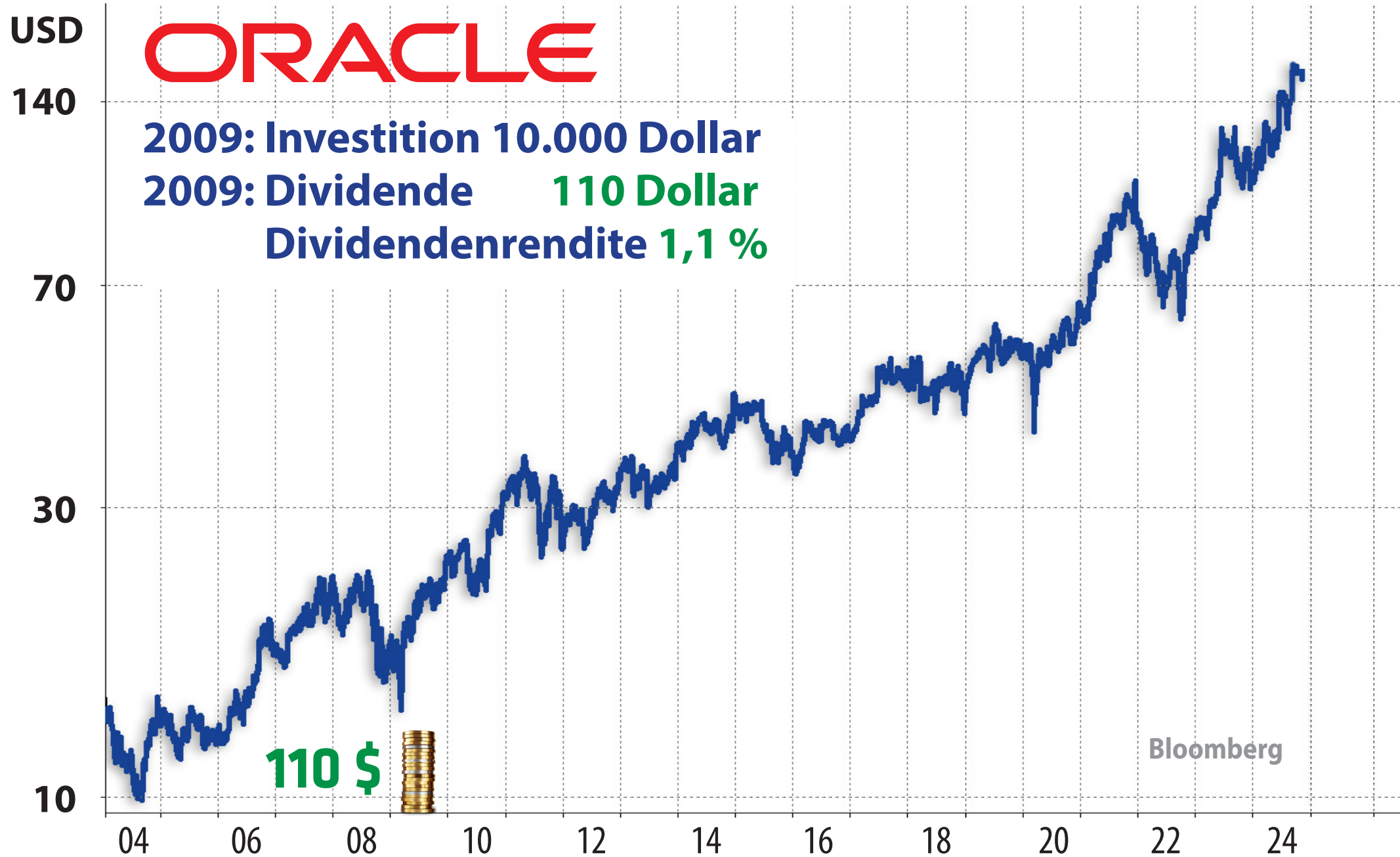

ORACLE

2009: Investition 10.000 Dollar

2014: Dividende 260 Dollar

pers. Dividendenrendite 2,6 %

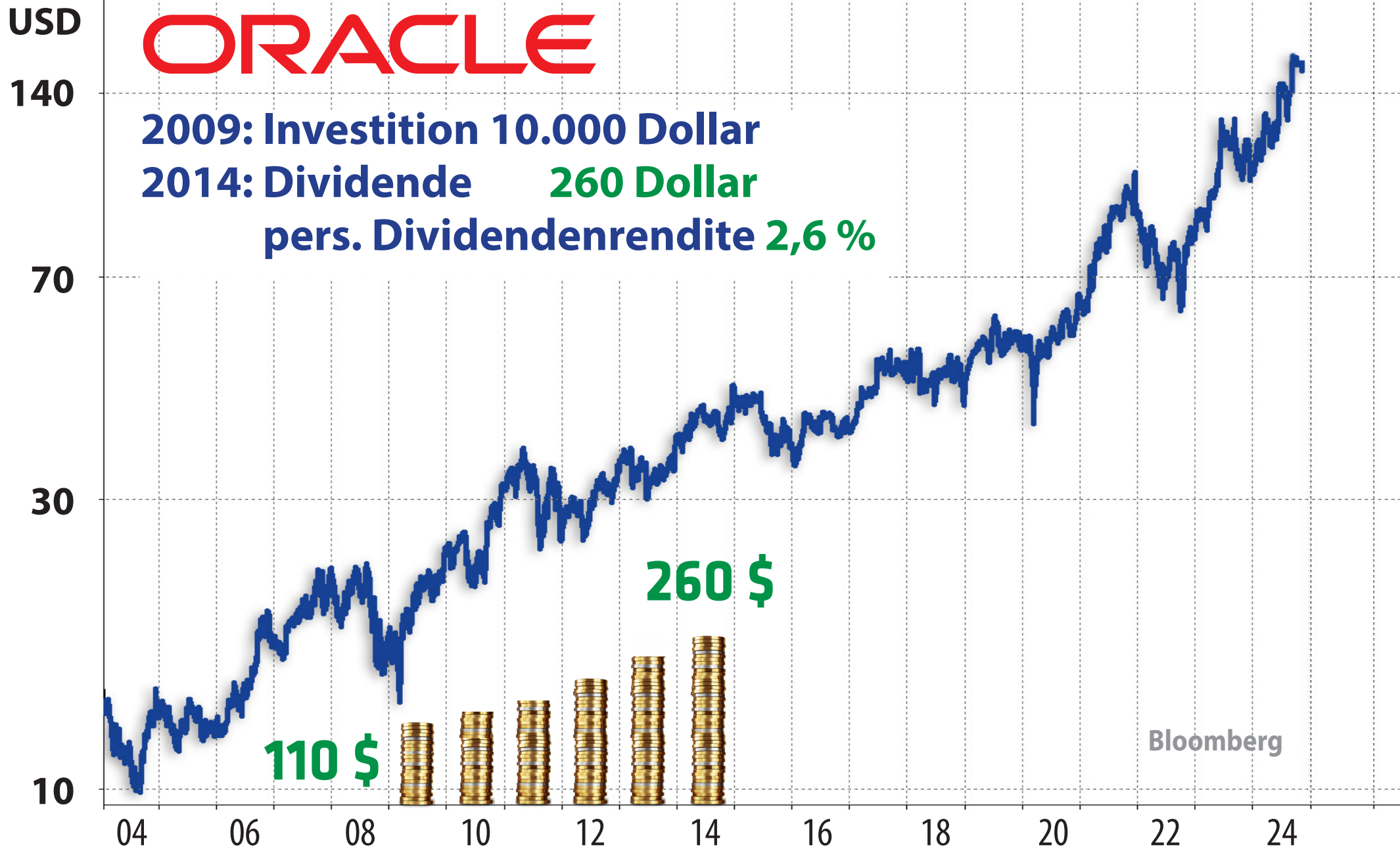

ORACLE

2009: Investition 10.000 Dollar

2019: Dividende **510 Dollar**

pers. Dividendenrendite **5,1 %**

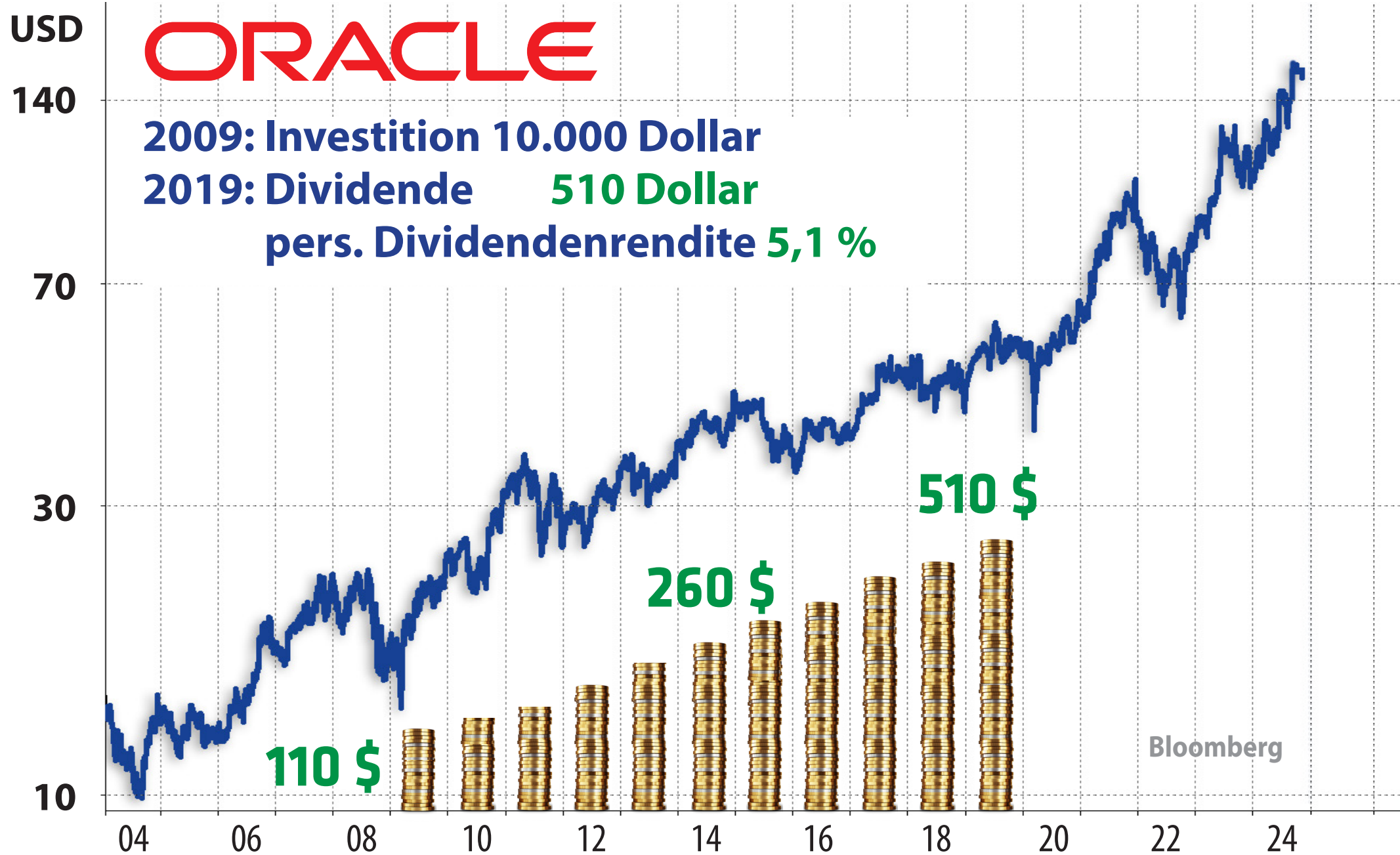

Bloomberg

ORACLE

2009: Investition 10.000 Dollar

2024: Dividende 900 Dollar

pers. Dividendenrendite 9,0 %

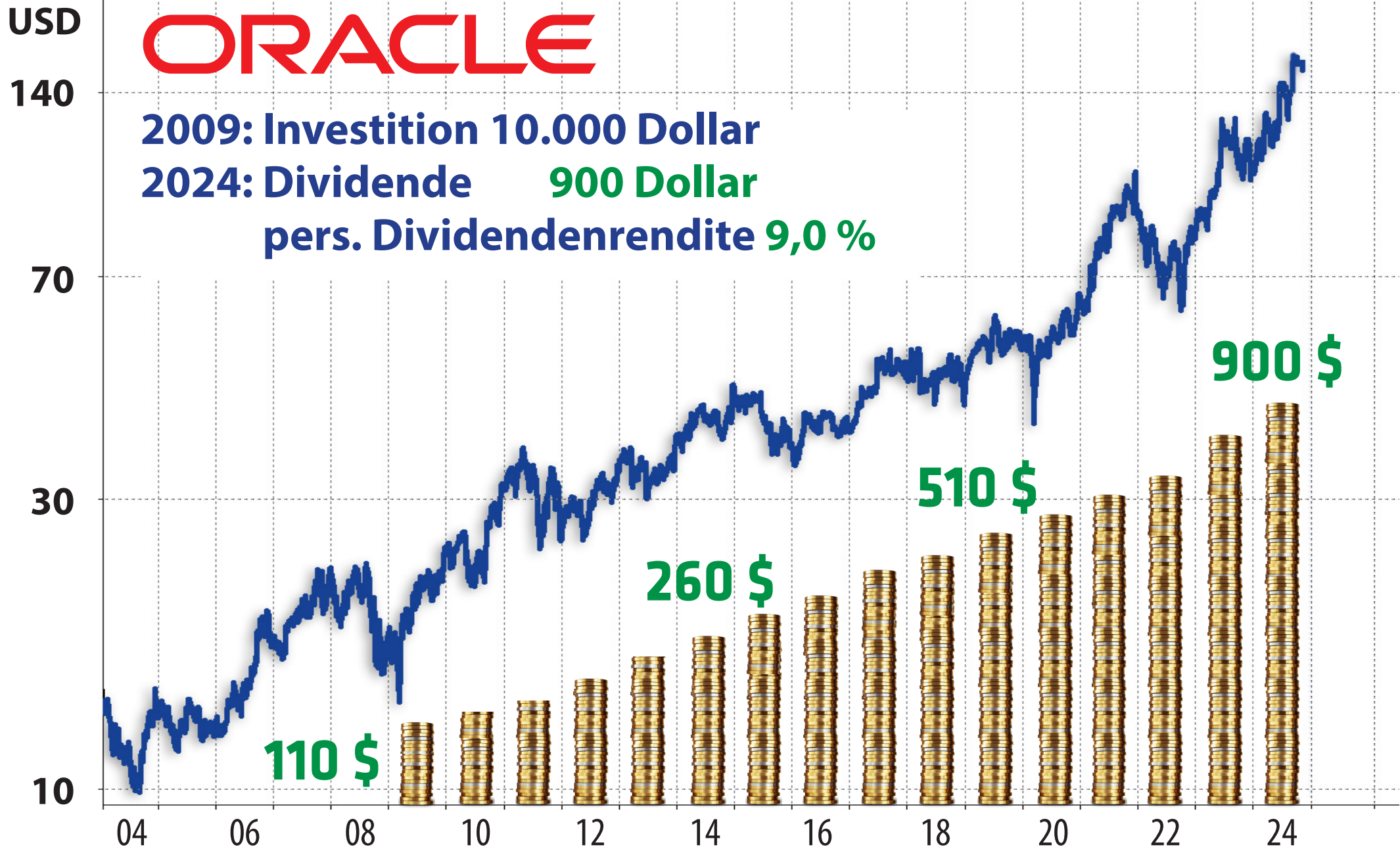

Heimliche Dividendenstars

aktuelle Dividende

PDR nach 15 Jahren

ORACLE

1,1 %



9 %

Heimliche Dividendenstars

aktuelle Dividende

PDR nach 15 Jahren

 mastercard

0,5 %

ORACLE

1,1 %



9 %

Heimliche Dividendenstars

aktuelle Dividende

PDR nach 15 Jahren

 mastercard

0,5 %

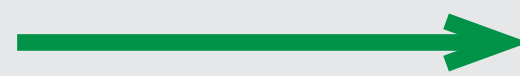

13 %

ORACLE

1,1 %



9 %

Heimliche Dividendenstars

aktuelle Dividende

PDR nach 15 Jahren

LVMH

2,2 %



20 %

 mastercard

0,5 %



13 %

ORACLE

1,1 %



9 %

Heimliche Dividendenstars

aktuelle Dividende

PDR nach 15 Jahren

STARBUCKS

2,4 %

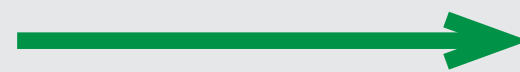

24 %

LVMH

2,2 %



20 %

 mastercard

0,5 %

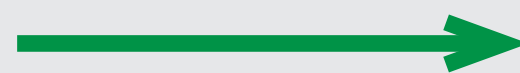

13 %

ORACLE

1,1 %



9 %

Heimliche Dividendenstars

aktuelle Dividende

PDR nach 15 Jahren

BECHTLE

1,9 %



26 %

STARBUCKS

2,4 %



24 %

LVMH

2,2 %



20 %

 mastercard

0,5 %

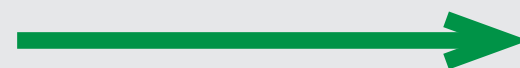

13 %

ORACLE

1,1 %



9 %

Heimliche Dividendenstars

aktuelle Dividende

PDR nach 15 Jahren

 novo nordisk

1,2 %

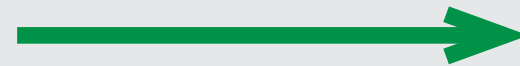

31 %

BECHTLE

1,9 %



26 %

STARBUCKS

2,4 %



24 %

LVMH

2,2 %



20 %

 mastercard

0,5 %



13 %

ORACLE

1,1 %



9 %

Heimliche Dividendenstars

aktuelle Dividende

PDR nach 15 Jahren

HOME DEPOT

2,3 %



32 %

novo nordisk

1,2 %



31 %

BECHTLE

1,9 %



26 %

STARBUCKS

2,4 %



24 %

LVMH

2,2 %



20 %

 mastercard

0,5 %

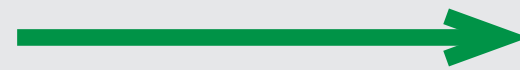

13 %

ORACLE

1,1 %



9 %

Nächster Referent:

**Joachim Brandmaier (62), Herausgeber
des Stuttgarter Aktienbriefs „Börse Aktuell“:**

„Jeder Tag ist Kauftag!“



Stuttgarter AktienBrief
WIR LEBEN BÖRSE – SEIT 1984



**November 1989
Börsen-Veranstaltung
in Stuttgart**



Stuttgarter AktienBrief
WIR LEBEN BÖRSE – SEIT 1984

Damals vor 35 Jahren:

**Preis für den am
weitesten angereisten
Besucher -**

- ein Original-Trabbi ...



Joachim Brandmaier, 26

1988

Optionsscheine im Brennpunkt



JOACHIM BRANDMAIER

Guten Tag, liebe Börsianer
und Options-Spekulanten.....

Börsenbrief Nr. 62

vom 23.01.1988

Der FAZ-Index hat es doch noch geschafft. Unser heimisches Börsenbarometer hat die psychologisch wichtige Marke von 500 Index-Punkten nachhaltig durchbrochen. Angesichts des wieder neu aufkeimenden Optimismus stürzen sich wieder viele Anleger auf die großen Gewinn versprechenden Optionsscheine.

Doch leider versäumen doch viele Anleger die Optionsscheine auf Aufgeld, Bezugspreis und der Laufzeit ausreichend zu prüfen. Denn nicht mit allen an der deutschen Börse gehandelten Optionsscheine kann man bei einem weiteren Kursanstieg enorm verdienen.

Auf die Kennzahlen kommt es an.

Denken Sie nur einmal an die spektakuläre Kursentwicklung des Philips-Optionsscheins seit Anfang dieses Jahres. Während die zugrundeliegende Aktie des Eindhovener Elektrokonzerns im selben Zeitraum 35 % im Kurs zulegen konnte, verlor der Schein mit seiner angeblich fünffachen Hebelwirkung die Hälfte seines Wertes. Eine solche Spekulation mit tragischem Ausgang hätte durch ein kurzes Studieren der Kennzahlen - natürlich vor der Kaufentscheidung - vermieden werden können.

Ein Optionsschein sollte zunächst einmal ein sehr geringes oder gar kein Aufgeld aufweisen. Nur dann hat ein Schein gute Chancen, parallel mit einem Anstieg der Aktie kräftig zuzulegen.

Hat ein Optionsschein extrem hohes Aufgeld und gleichzeitig einen sehr hohen Hebel (Philips-Optionsschein), dann gilt er als sehr spekulativ. Ein solcher Schein kann bei einem Kursanstieg der zugrundeliegenden Aktie sehr stark anziehen, muß aber nicht. Es gibt bei solchen Scheinen keine Garantie, die große Hebelwirkung bleibt oft nur ein theoretischer Wert.



Joachim Brandmaier, 26

1988



**Joachim Brandmaier (62), Herausgeber
des Stuttgarter Aktienbriefs „Börse Aktuell“:**

„Jeder Tag ist Kauftag!“



Stuttgarter AktienBrief
WIR LEBEN BÖRSE – SEIT 1984



Handelsblatt

Der Dow Jones steigt auf ein neues Rekordhoch

Mit dem Anstieg auf über 44.000 Punkte hat der Dow Jones und der marktbreitere S&P-Index Anfang ein neues All-Time-High erreicht.

manager magazin

Historisches Hoch beim DAX

Die Rekordjagd an der Börse geht weiter: An der Frankfurter Börse erreichte der DAX mit 19.657 Punkten am vergangenen Freitag ein historisches Hoch.

Wirtschafts Woche

Allzeithoch an den Börsen

Im späten Handel am Donnerstag überschritt der MSCI World Index die Marke von 3.790 Punkten und markierte damit eine neue Rekordmarke.



Dow-Jones-Index



Dow-Jones-Index

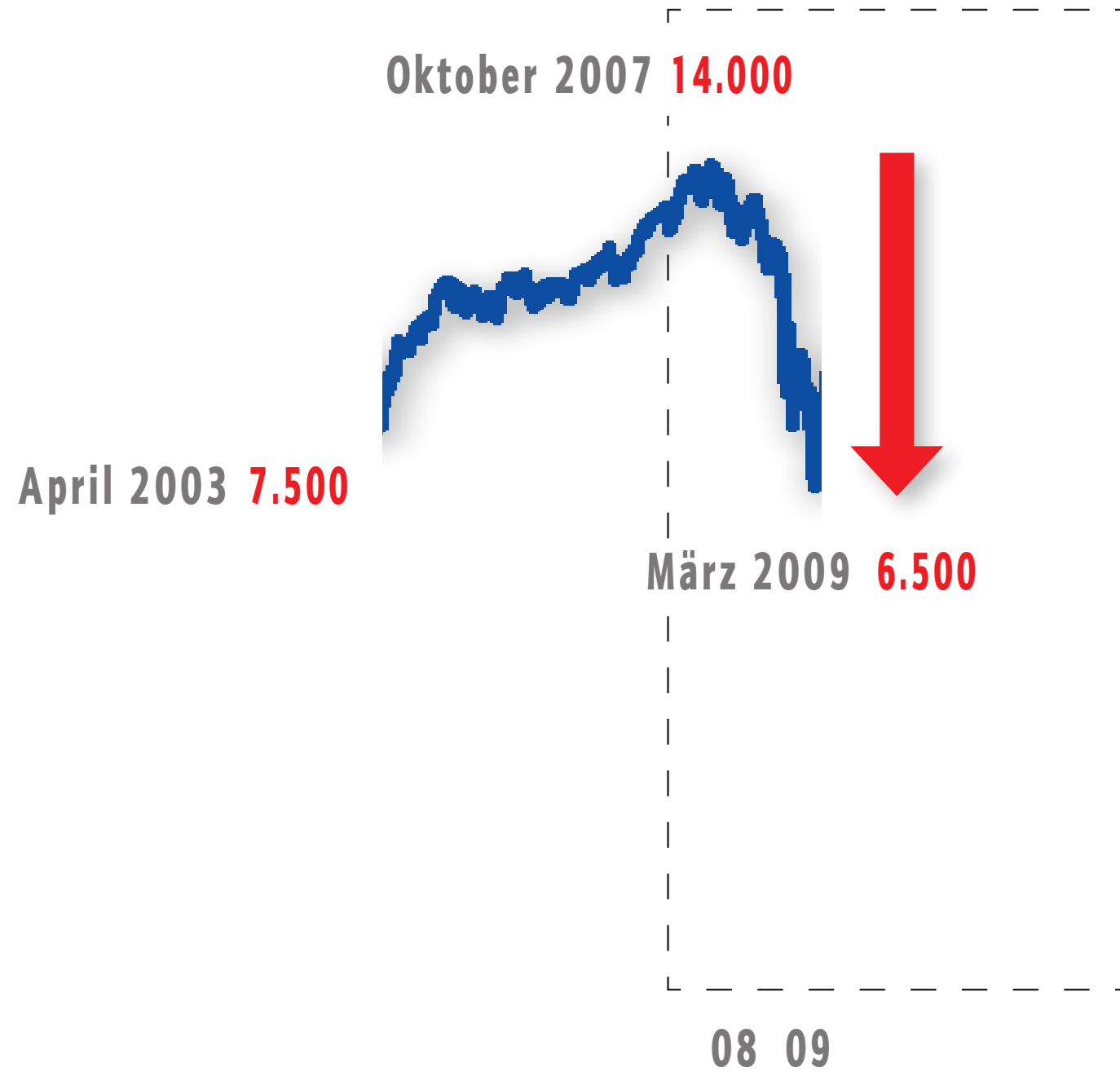

Dow-Jones-Index



April 2003 7.500

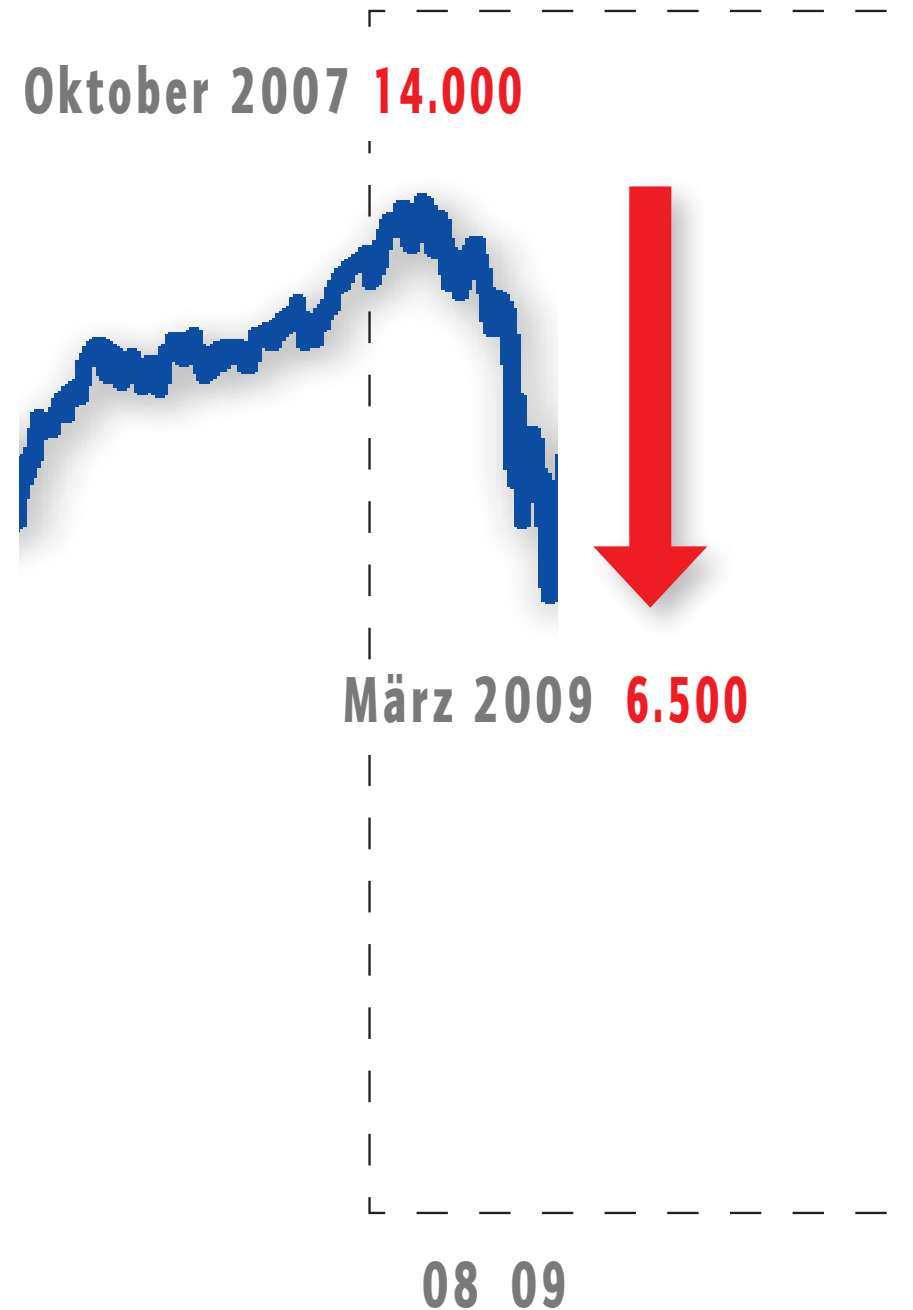

Dow-Jones-Index



Dow-Jones-Index



Dow-Jones-Index

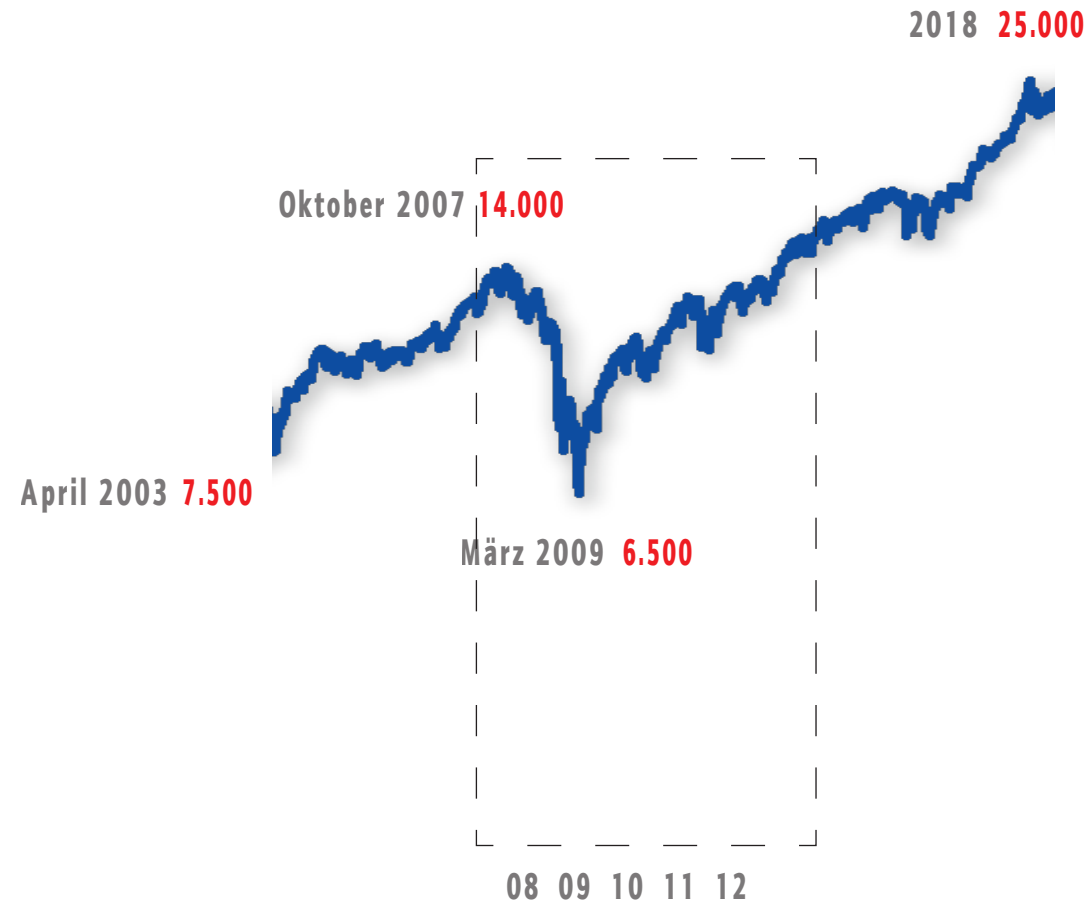

Dow-Jones-Index

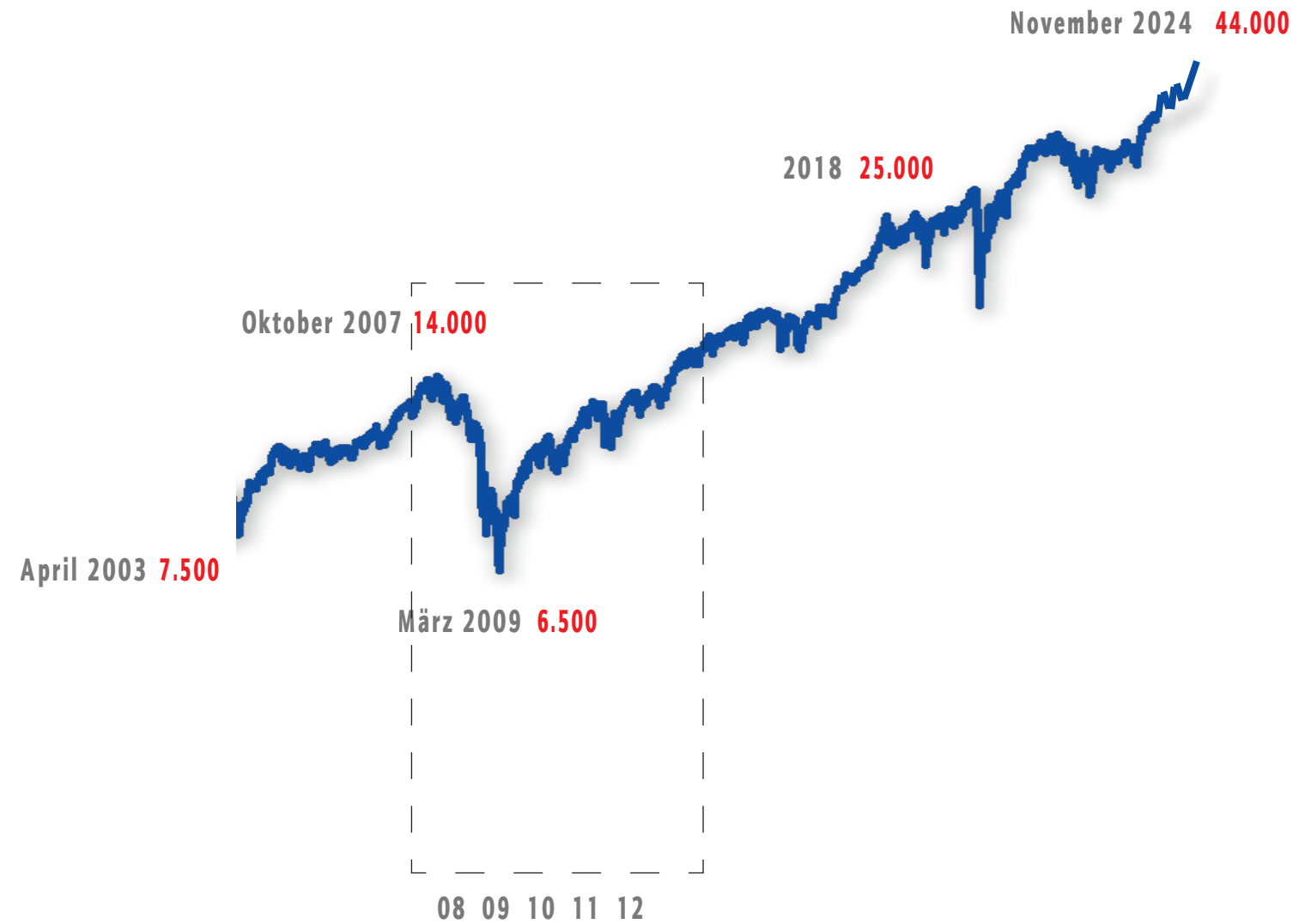

Dow-Jones-Index



Dow-Jones-Index

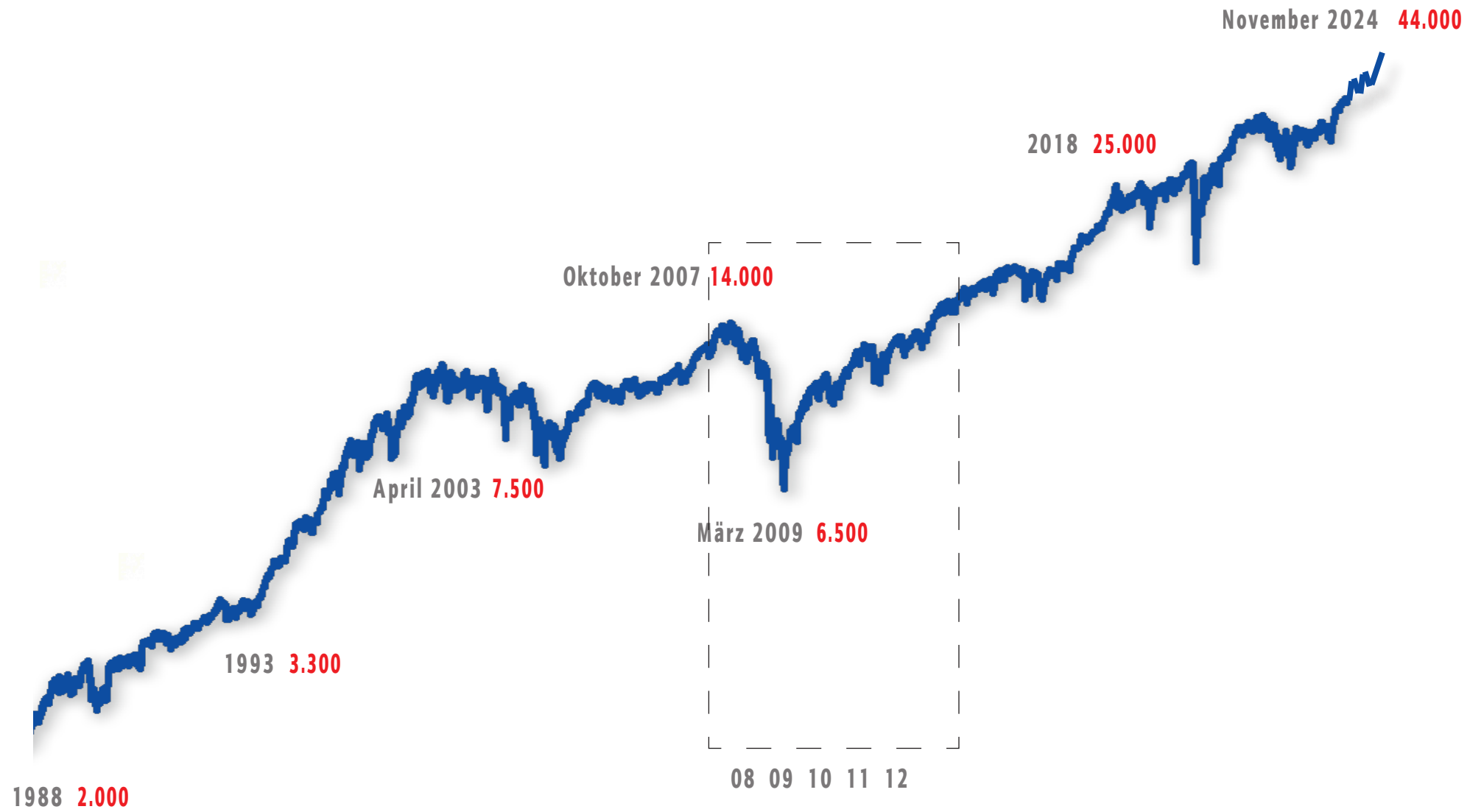

Dow-Jones-Index

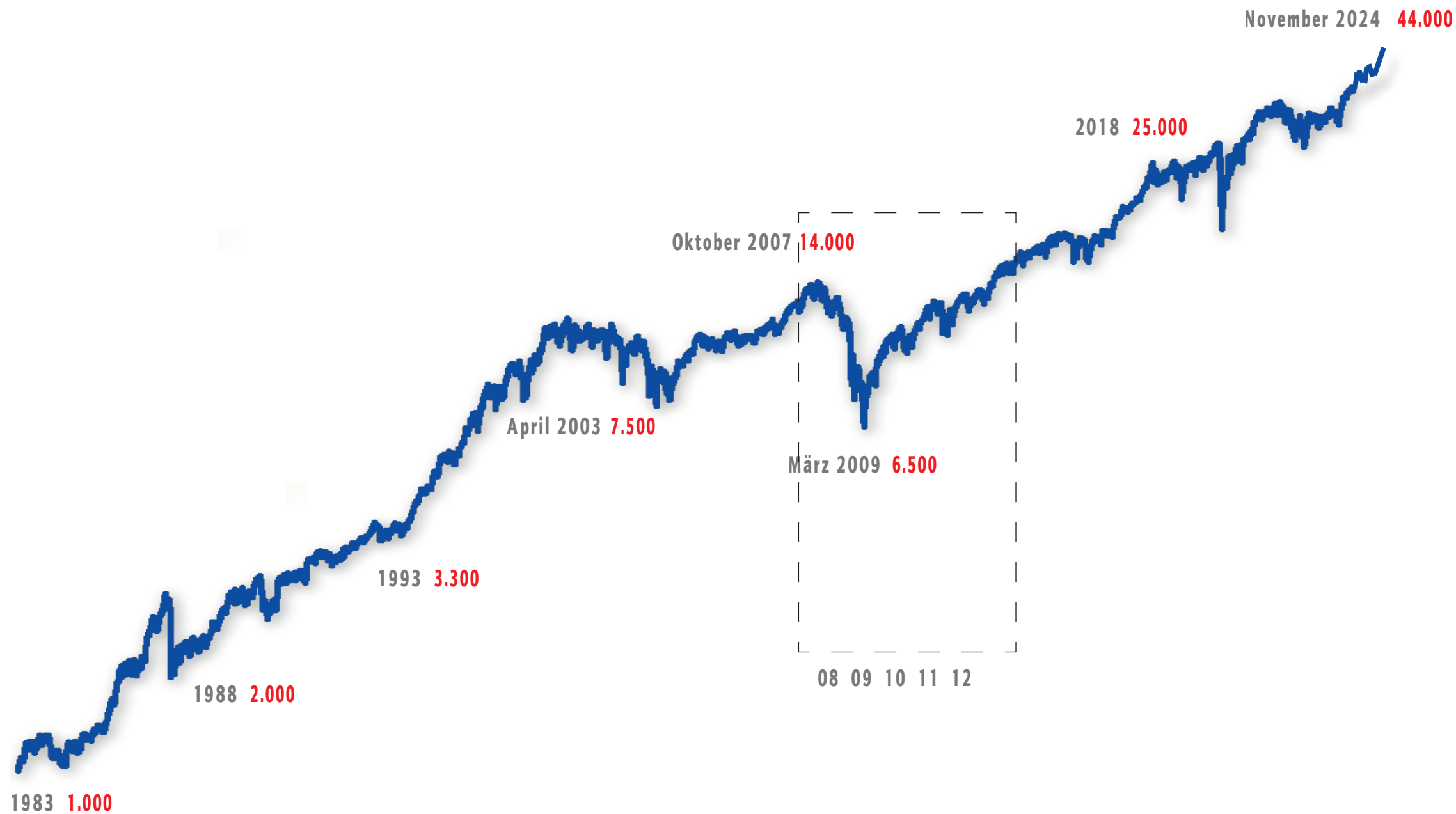

Dow-Jones-Index

Über 40 Jahre aufwärts: 1983 - 2024



Dow-Jones-Index

Allen Krisen zum Trotz: langfristig nach oben ...



Dow-Jones-Index

Allen Krisen zum Trotz: langfristig nach oben ...



Dow-Jones-Index

Allen Krisen zum Trotz: langfristig nach oben ...

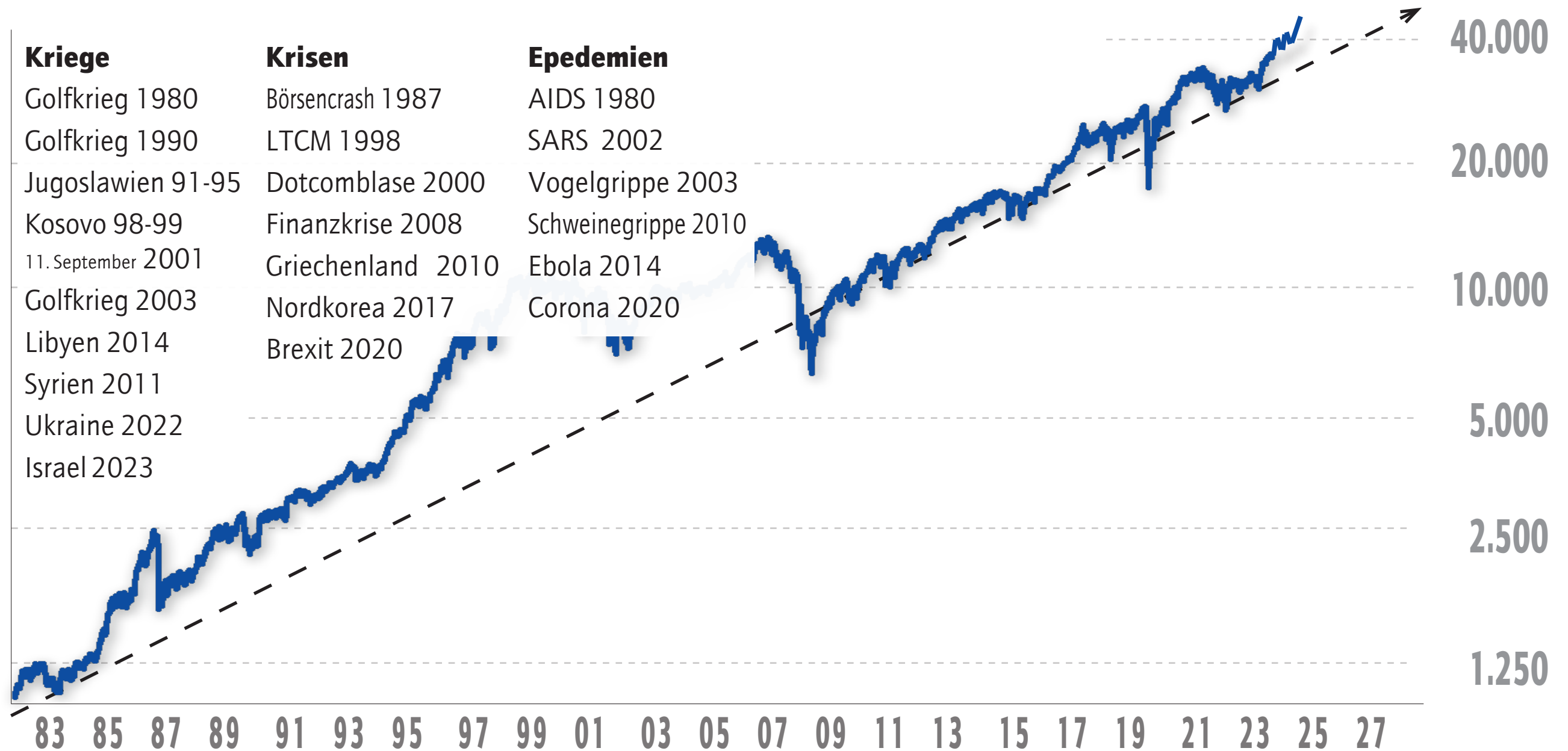

Dow-Jones-Index

Allen Krisen zum Trotz: langfristig nach oben ...

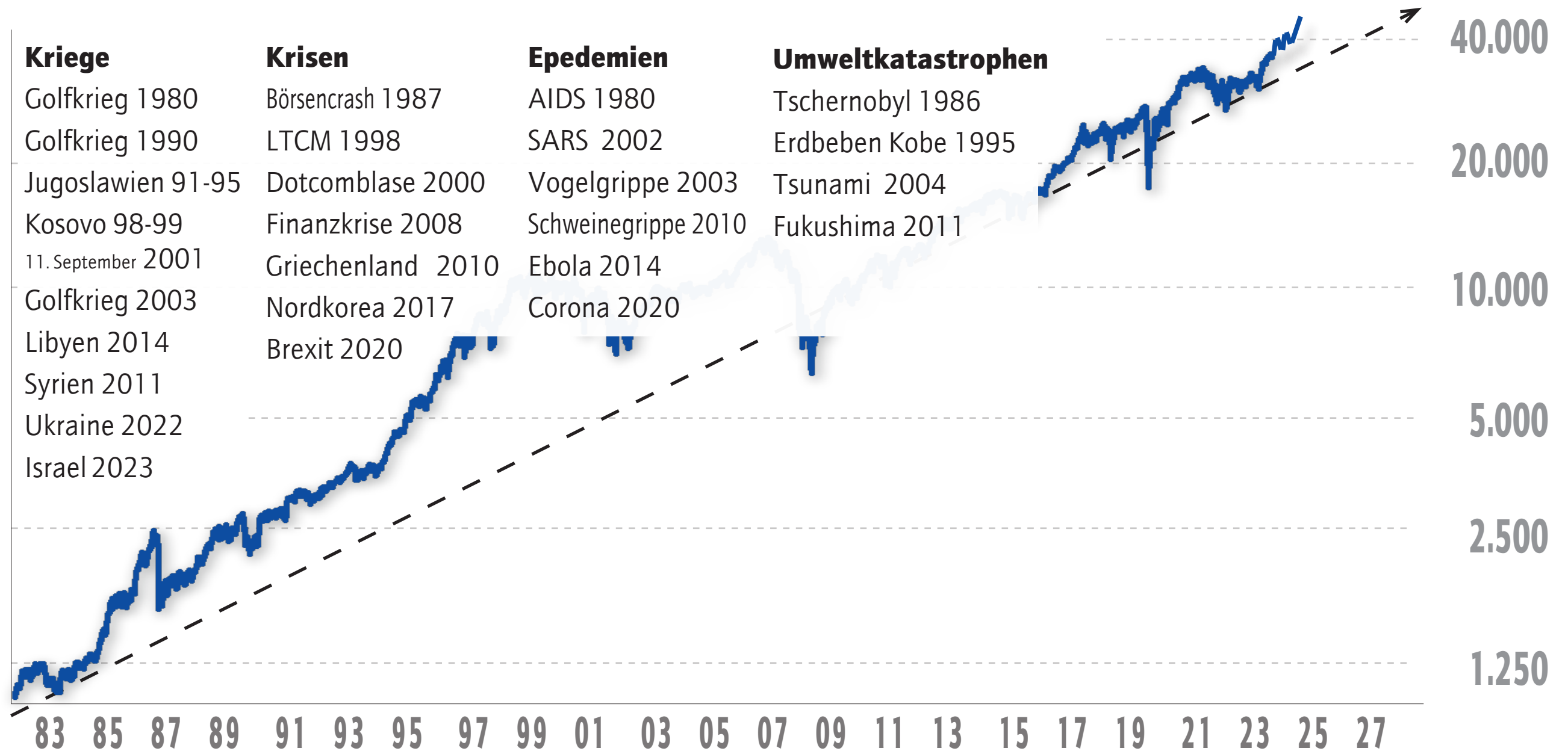

Dow-Jones-Index

Über 40 Jahre aufwärts: 1983 - 2024



Dow-Jones-Index

Allen Präsidenten zum Trotz: langfristig nach oben ...

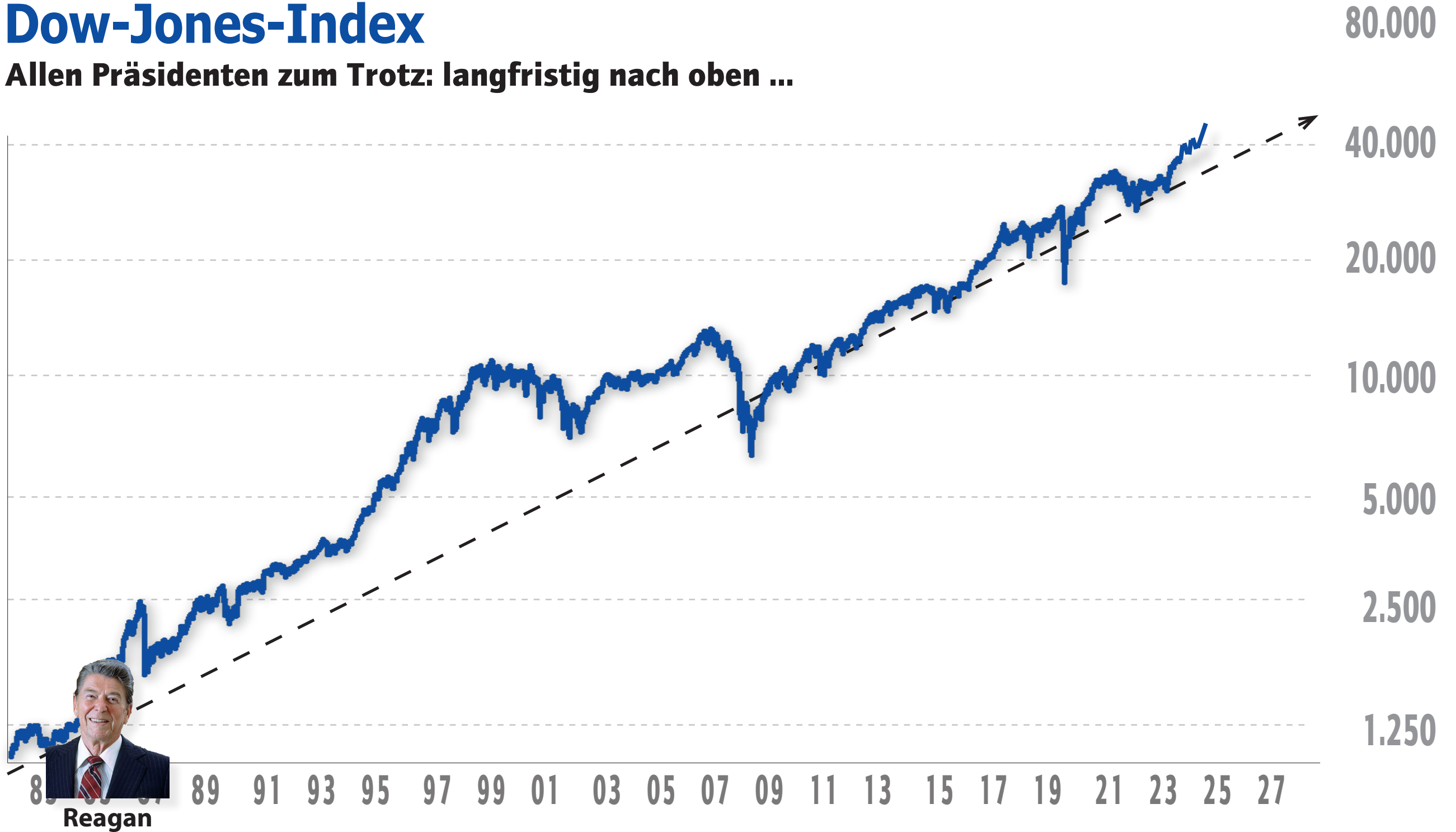

Dow-Jones-Index

Allen Präsidenten zum Trotz: langfristig nach oben ...

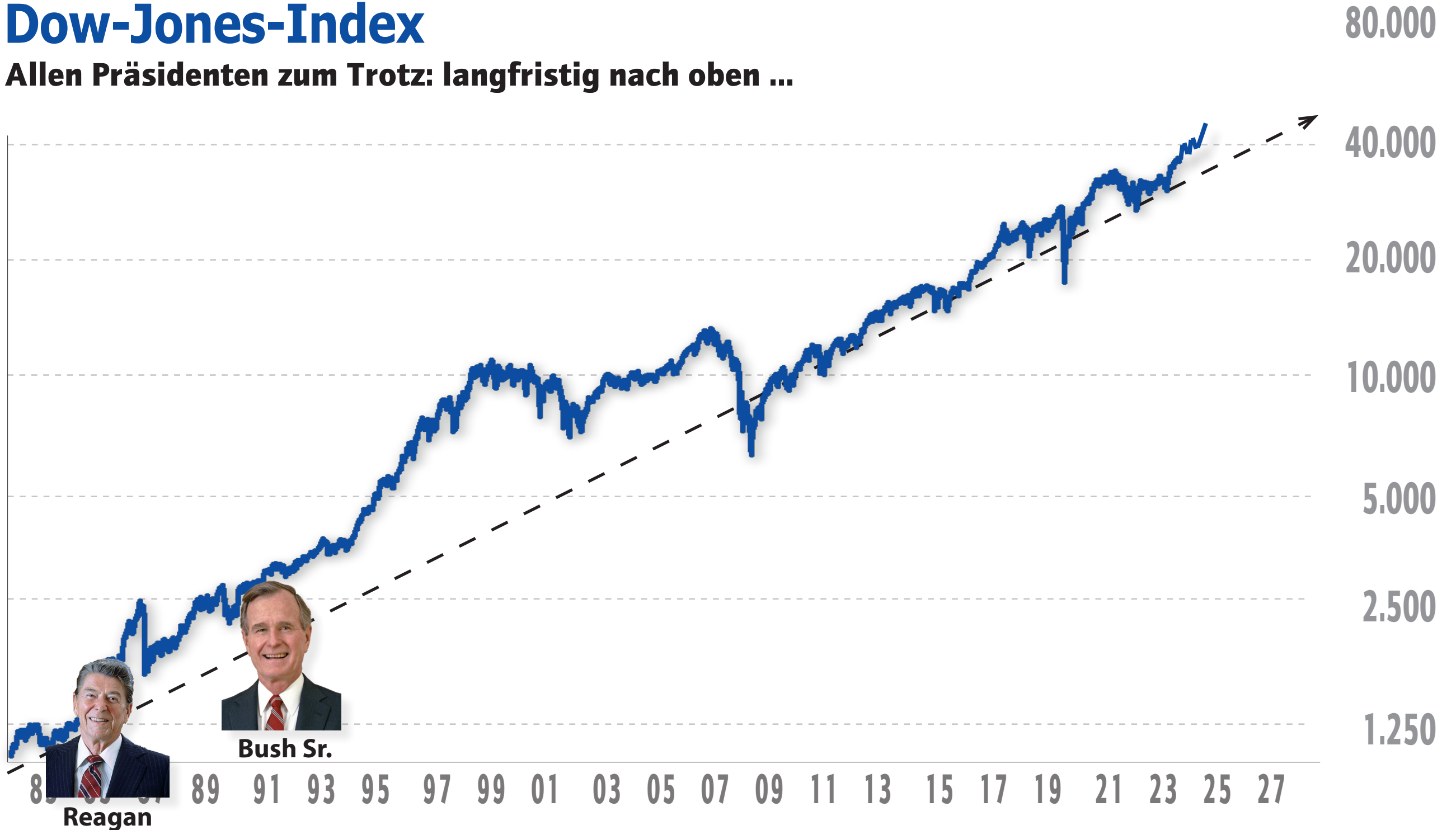

Dow-Jones-Index

Allen Präsidenten zum Trotz: langfristig nach oben ...

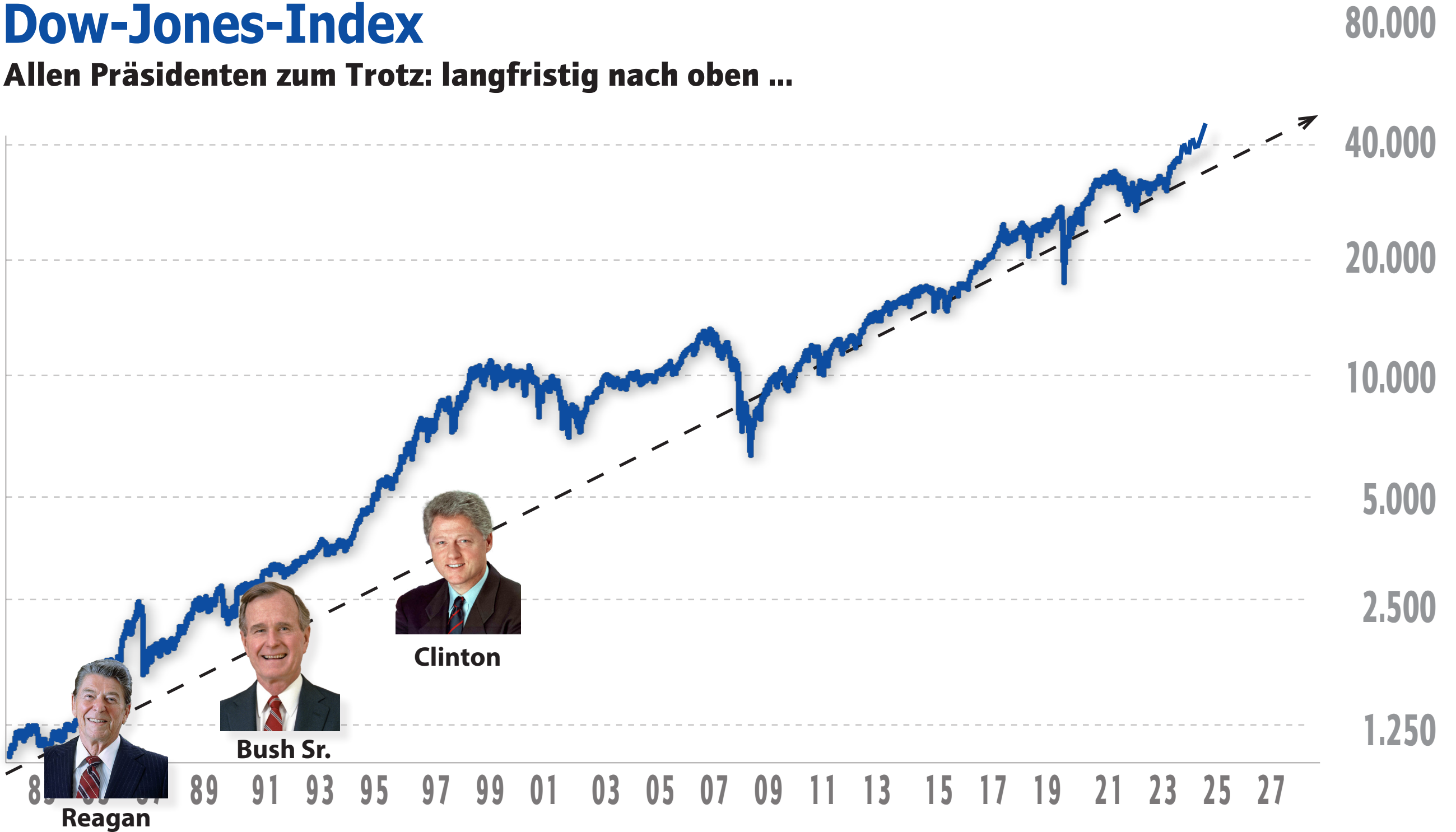

Dow-Jones-Index

Allen Präsidenten zum Trotz: langfristig nach oben ...

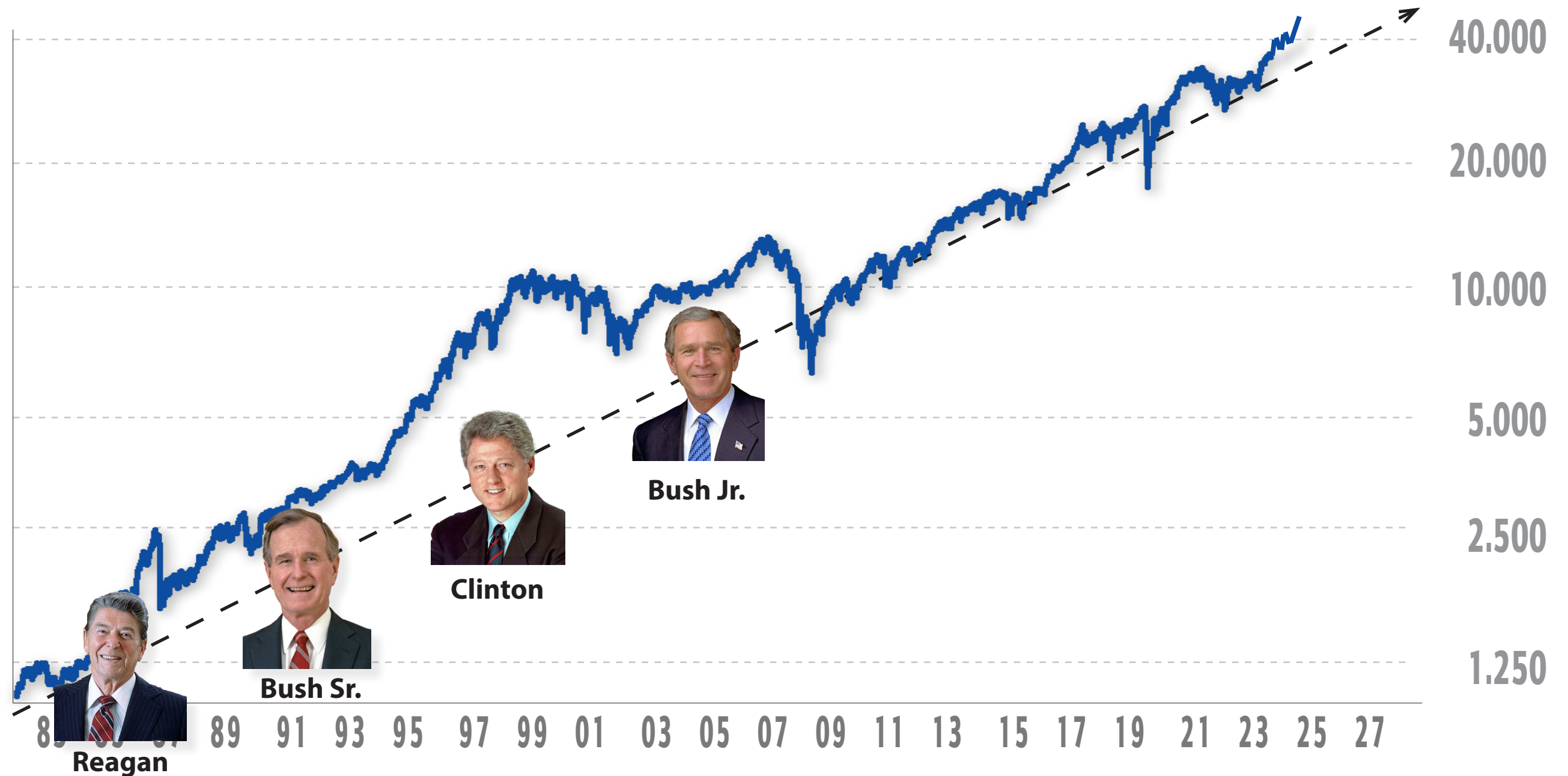

Dow-Jones-Index

Allen Präsidenten zum Trotz: langfristig nach oben ...



Dow-Jones-Index

Allen Präsidenten zum Trotz: langfristig nach oben ...

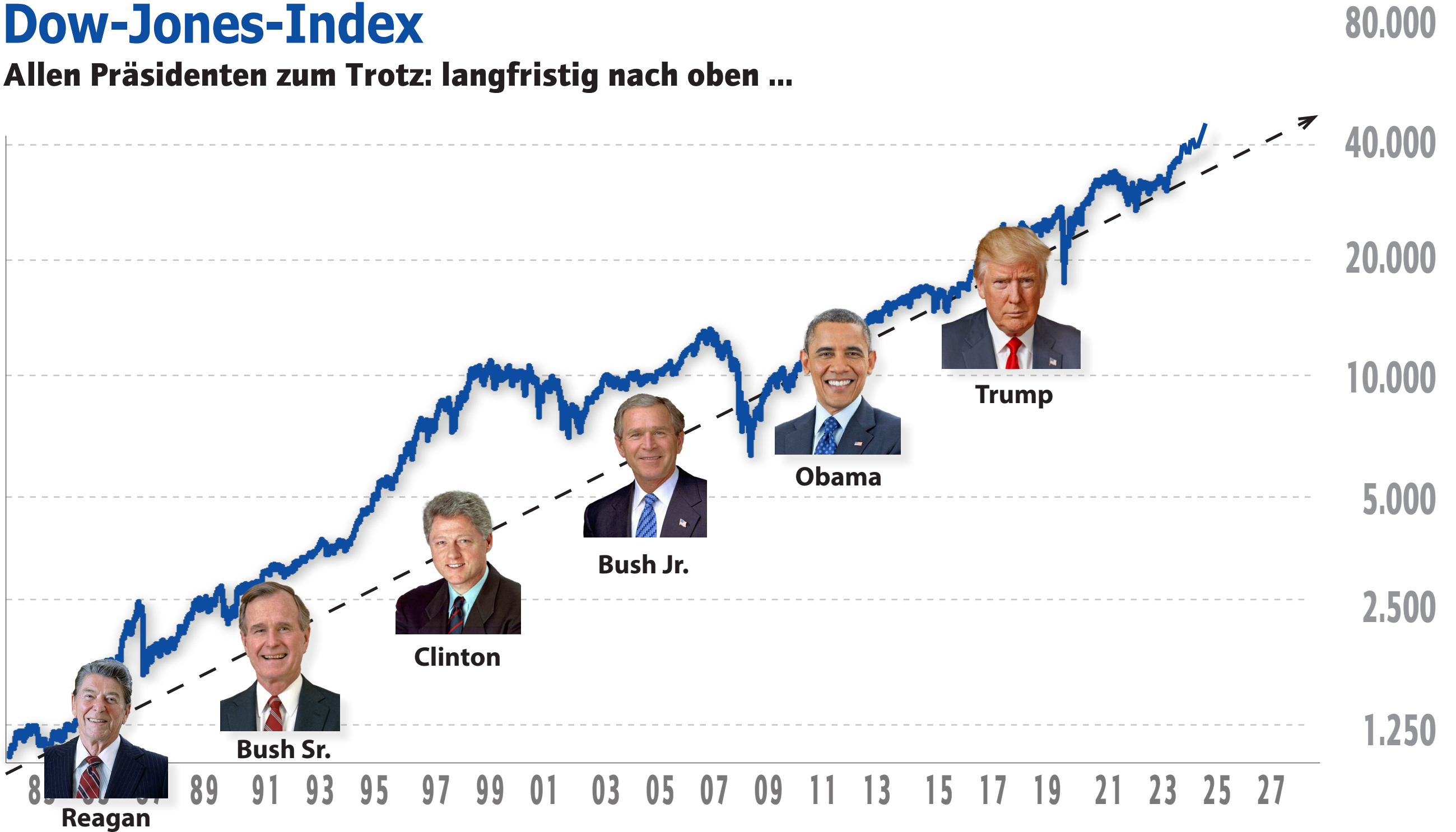

Dow-Jones-Index

Allen Präsidenten zum Trotz: langfristig nach oben ...



Dow-Jones-Index

Über 40 Jahre aufwärts: 1983 - 2024

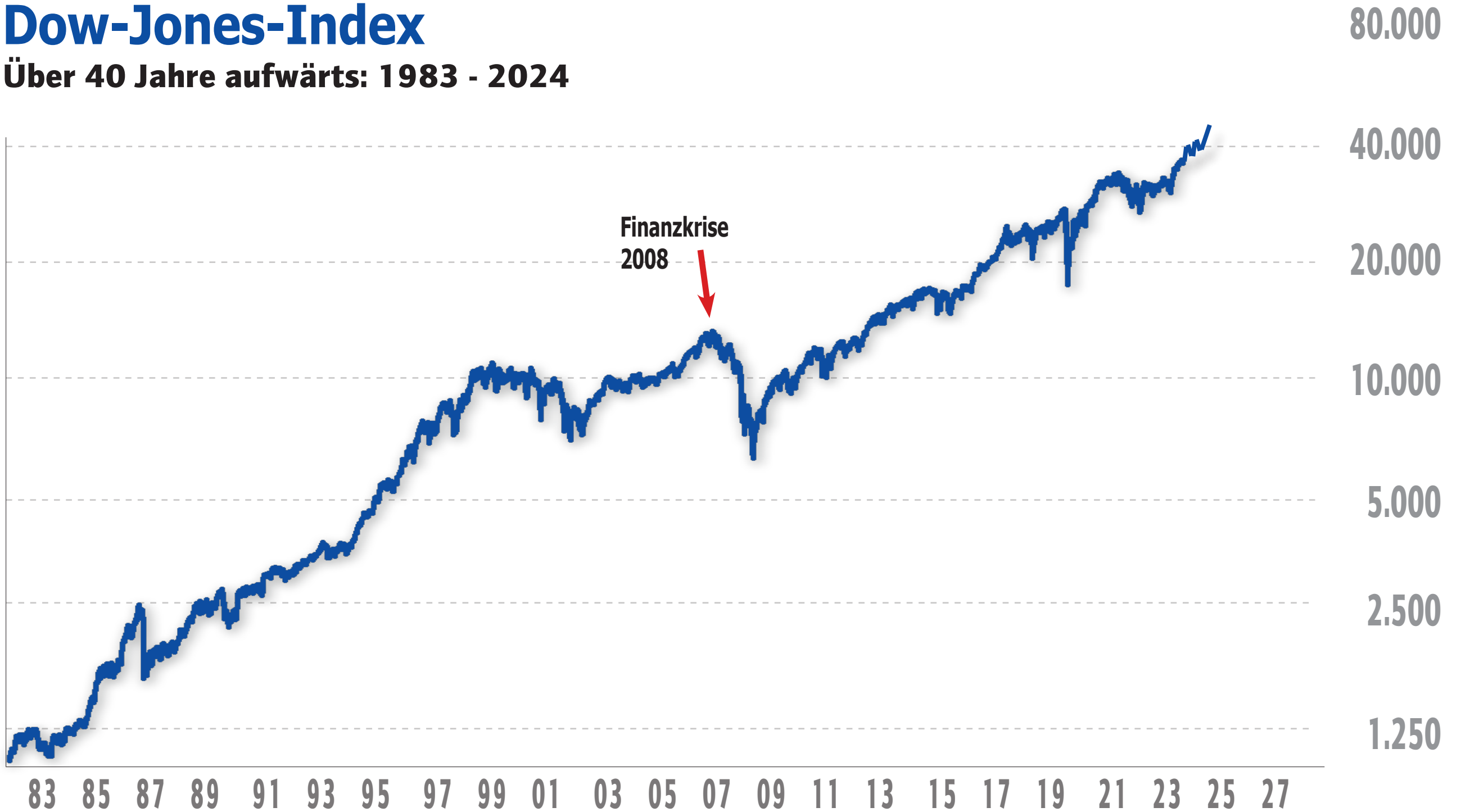

Dow-Jones-Index

Über 40 Jahre aufwärts: 1983 - 2024

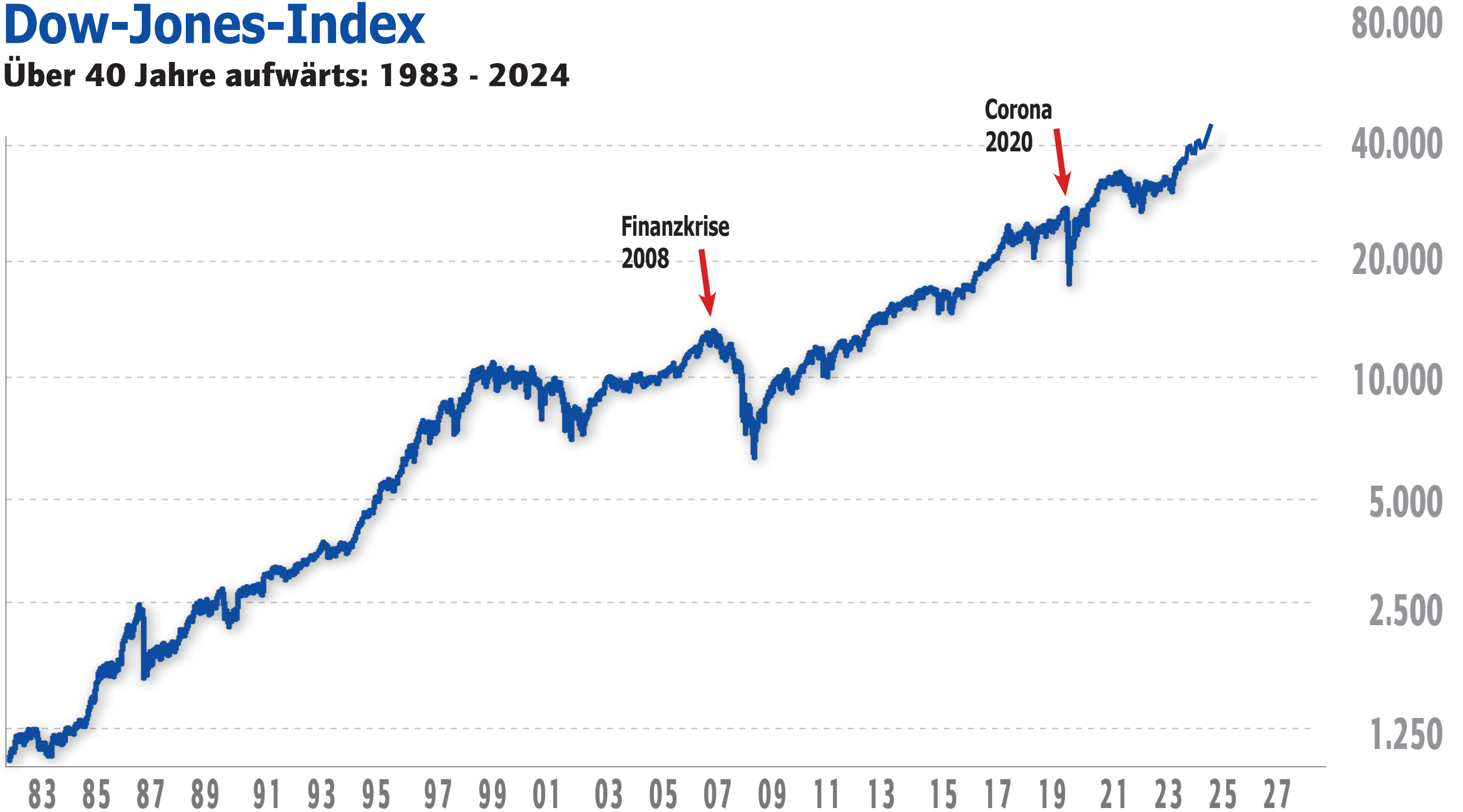

Dow-Jones-Index

Über 40 Jahre aufwärts: 1983 - 2024

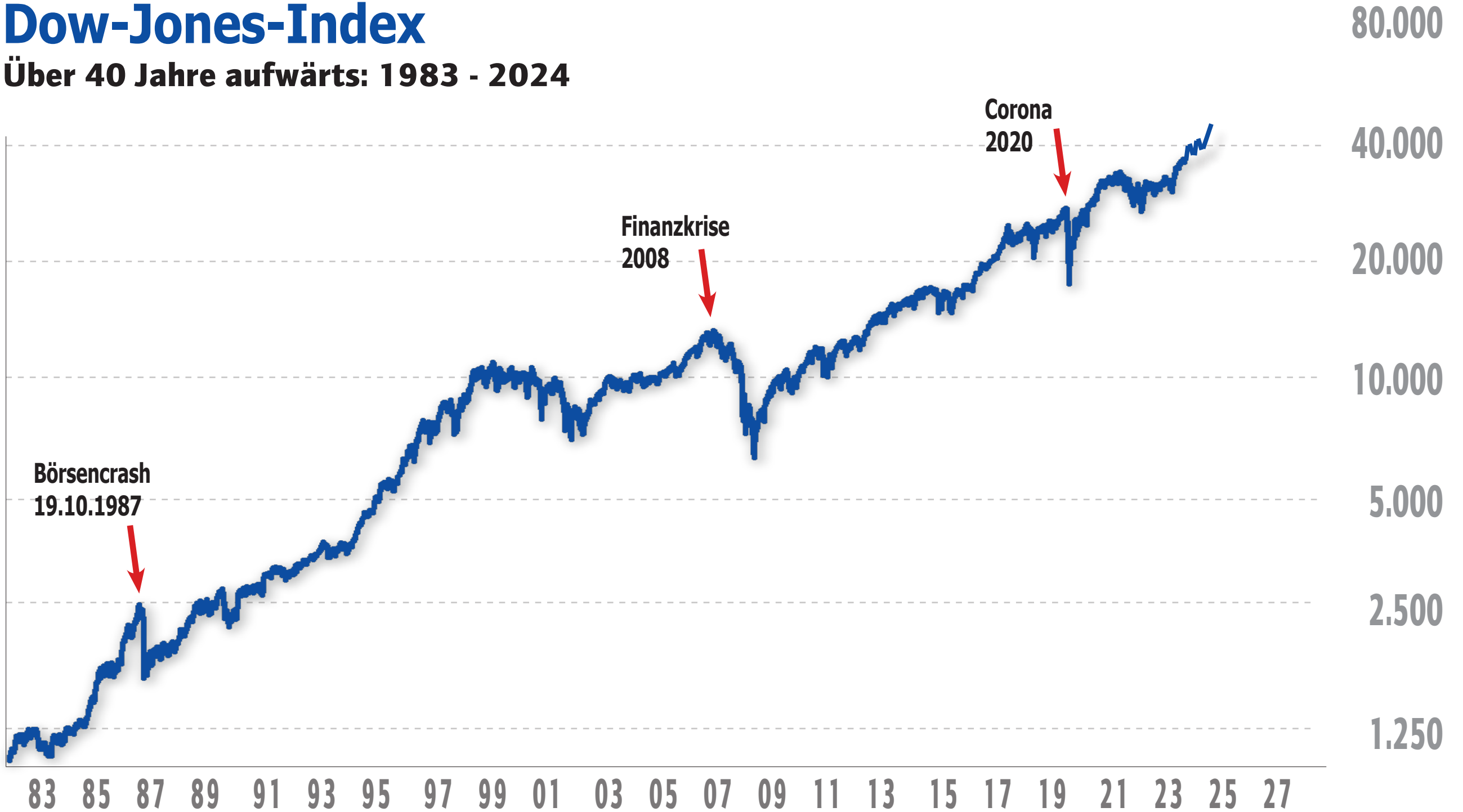

Dow-Jones-Index

Über 40 Jahre aufwärts: 1983 - 2024



Dow-Jones-Index

Über 40 Jahre aufwärts: 1983 - 2024

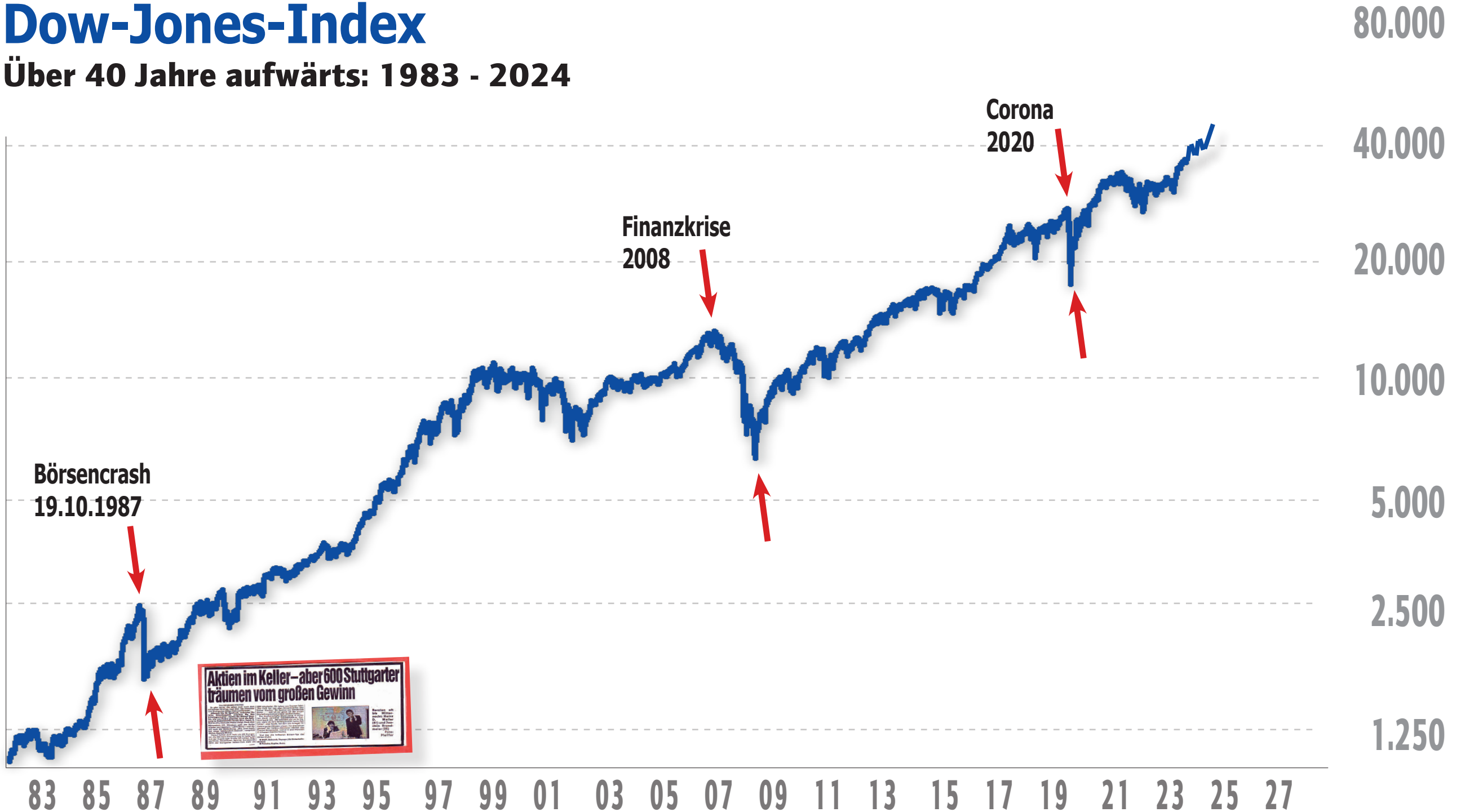

Hoffnungslose Narren

Aktien im Keller – aber 600 Stuttgarter träumen vom großen Gewinn

Von REINHARD PFEIFFER

Es gibt Leute, die sehen auch nach dem schwarzen Montag noch klar: Die Börsianer vom Stuttgarter Aktien Club zum Beispiel...

„Räumen Sie Ihr Sparbuch, verkaufen Sie Ihren Orientteppich, enterben Sie Ihre Schwiegermutter – kaufen Sie Aktien!“ Rastlos, wie von Fieber gepackt, rennt die Spürnase im Nadelstreifen durchs Büro: Heinz D. Weiler (41). Und sein Fieber steigt. Nach dem Börsensturz (19. Oktober) geht der Dollar wieder rauf (gestern: 1,6475 Mark) – und damit auch die Aktienkurse. „Wer jetzt kauft, hat einen Jahrhundert-Chance“, verspricht Aktien-Experte Weiler.

Darauf hoffen auch mehr als 600 Stuttgarter, die 288 Mark Jahresbeitrag für heiße Tips aus der Augsburger Straße 562 zahlen. Baggerführer, Hausfrauen, Rentner. Bundesweit zählt der Stuttgarter Aktien-Club mehr als

2000 Mitglieder. Ein Lehrer aus Bremen lobt: „Der Club hat von allen Börsenbriefen den besten. Riecher.“ Ein Rentner aus Osnabrück dankt: „... daß ich mir gleich mit der ersten Empfehlung meinen Urlaub verdient habe.“

Das Gemeinschafts-Depot (rund 15 Millionen Mark) verwaltet Geschäftsführer Gerhard Epple (50). „Wir kümmern uns um ihr Depot, wenn sie für's Aktiengeschäft keine Zeit haben“, sagt Epple, bei dem die Anleger ihr Geld in guten Händen wissen. Vor drei Jahren gewann der Vollblut-Börsianer nämlich das Capital-Börsenspiel, weil er in drei Monaten 27,4 Prozent Gewinn machte.



Beraten oft bis Mitternacht: Heinz D. Weiler (41) und Joachim Brandmaier (25)

Foto: Pfeiffer

Die Bild-Zeitung am 20. Oktober 1987, einen Tag nach dem großen Crash:

Es gibt Leute, die sehen auch nach dem schwarzen Montag klar: „Räumen Sie Ihr Sparbuch, kaufen Sie jetzt Aktien. Wer jetzt Aktien kauft, hat eine Jahrhundertchance!“, verspricht Joachim Brandmaier, 25, vom Stuttgarter Aktien-Club ...

Dow-Jones-Index

Über 40 Jahre aufwärts: 1983 - 2024

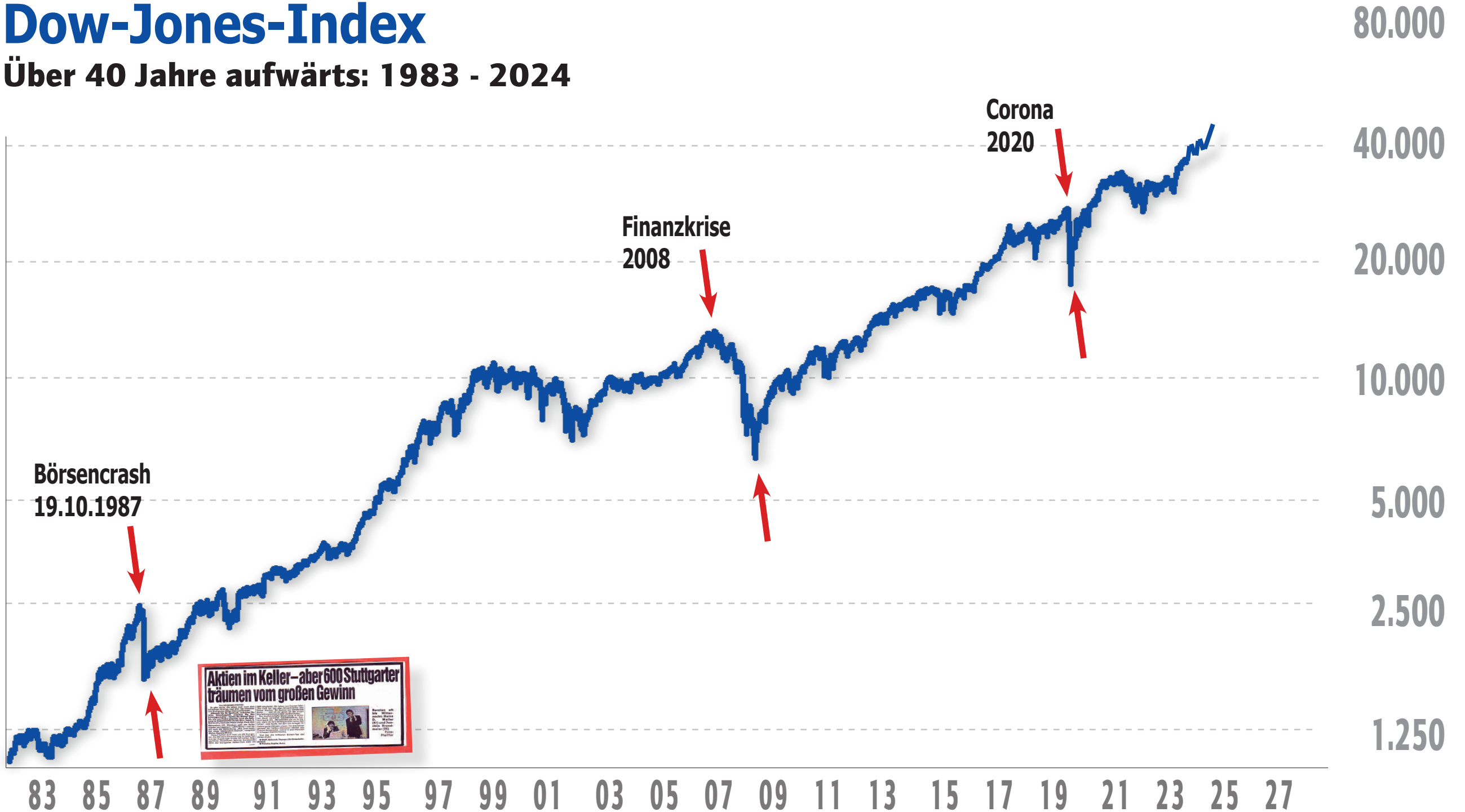

Dow-Jones-Index

Über 40 Jahre aufwärts: 1983 - 2024

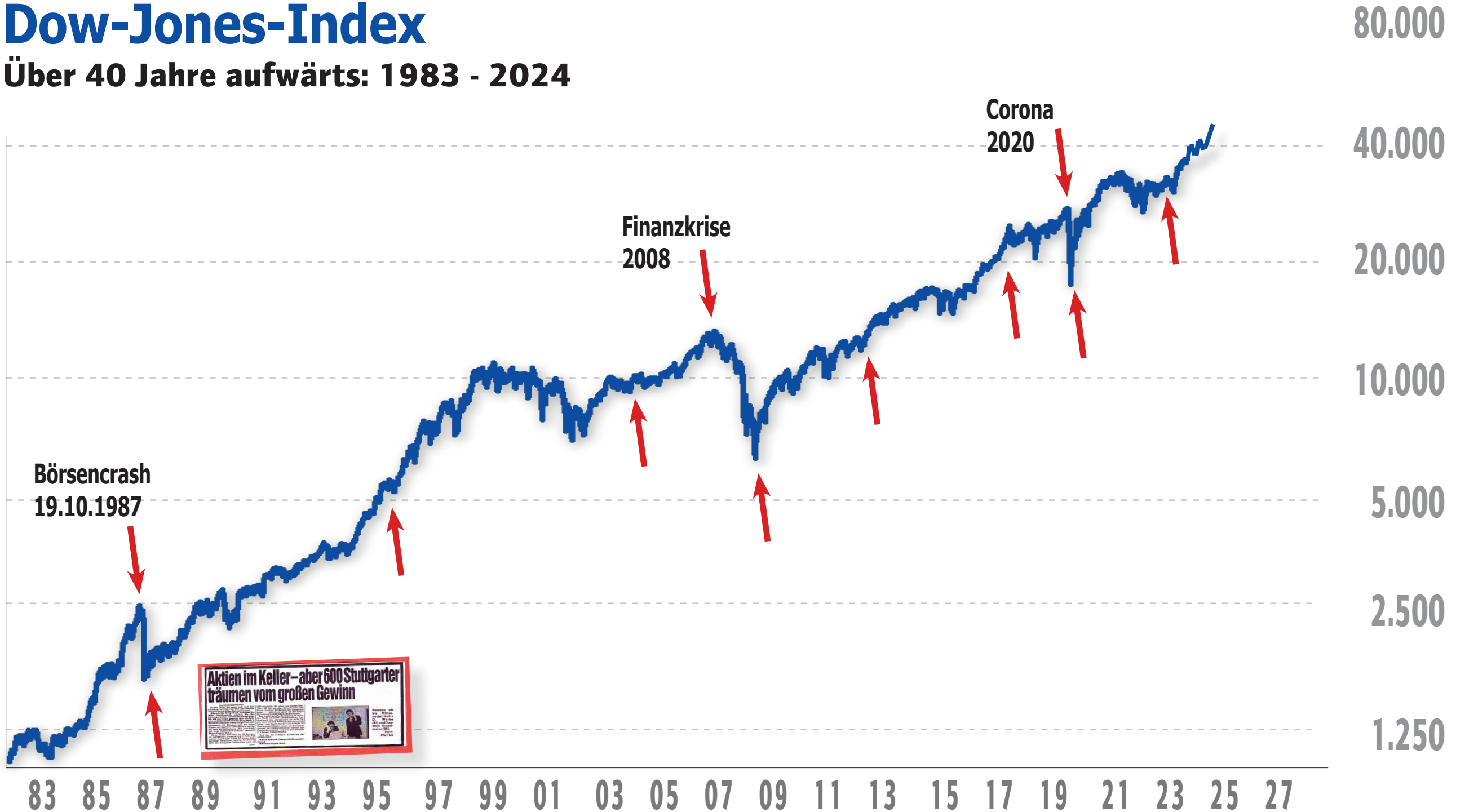

Dow-Jones-Index

Über 40 Jahre aufwärts: 1983 - 2024

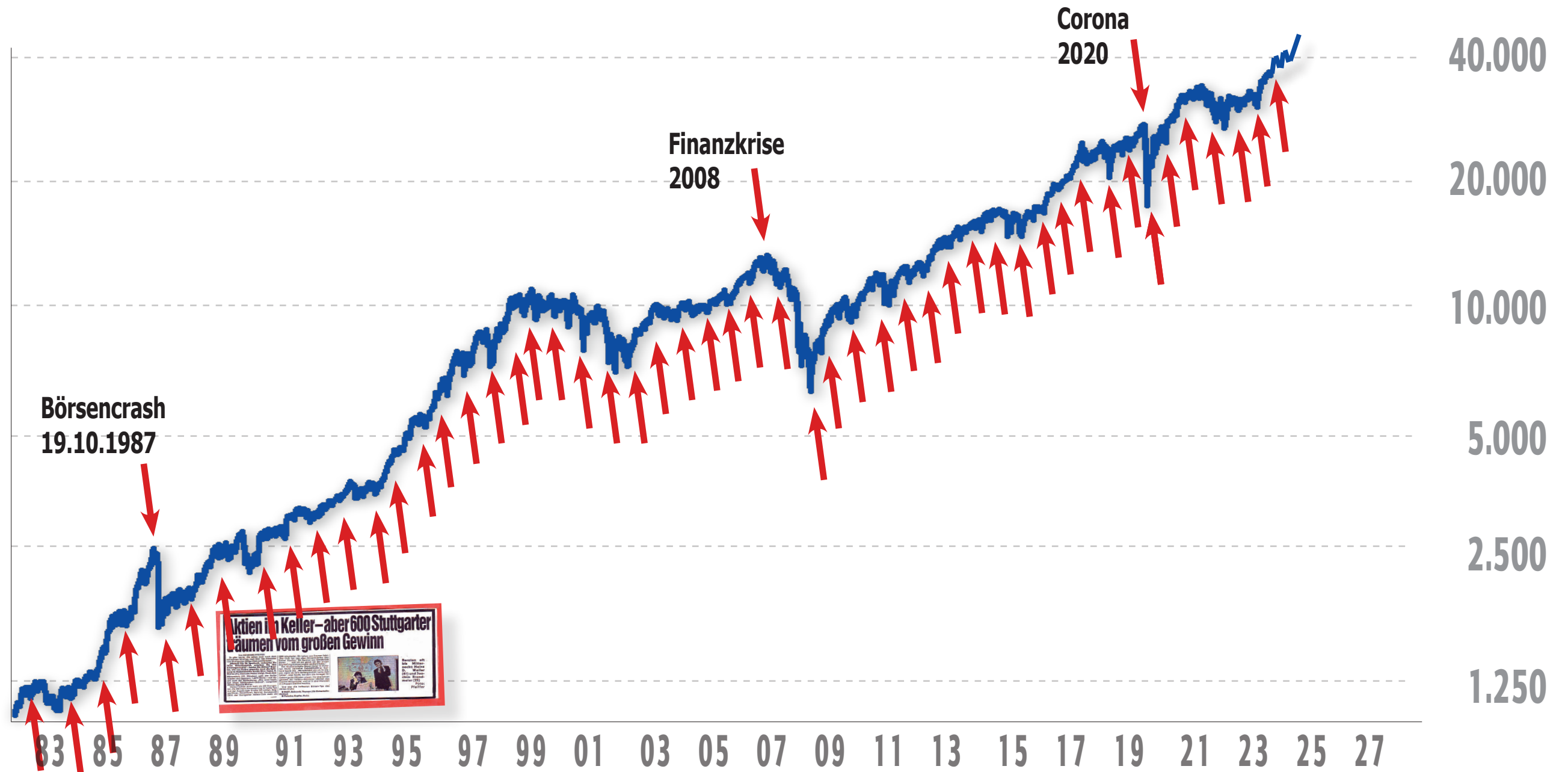

Dow-Jones-Index

Über 40 Jahre aufwärts: 1983 - 2024

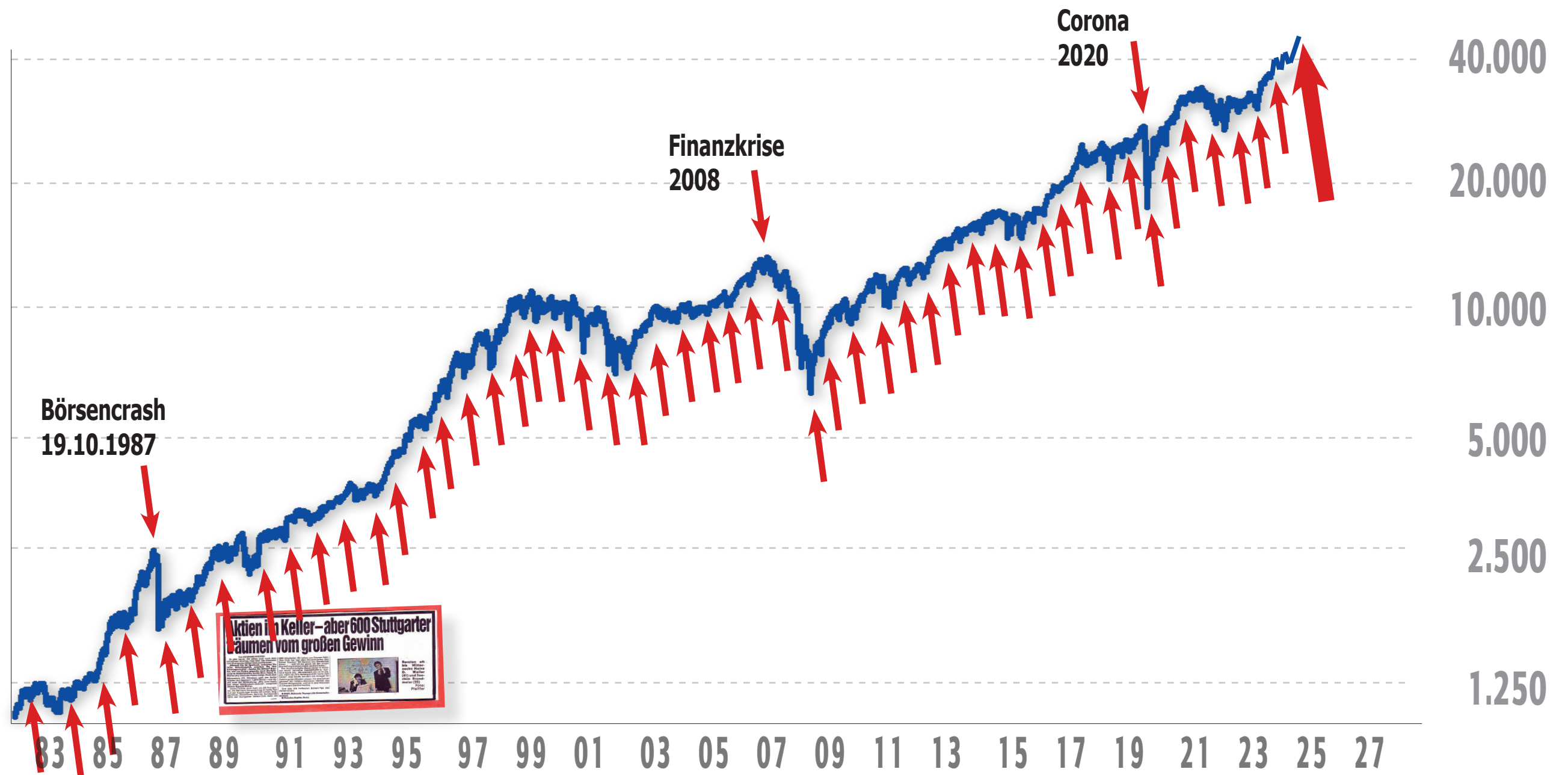

Das richtige Werkzeug für den Börsenerfolg?

Das richtige Werkzeug für den Börsenerfolg?

$$C = S_0 N(d_1) - X e^{-rT} N(d_2)$$

$$\text{mit } d_1 = \frac{\ln\left(\frac{S_0}{X}\right) + rT}{\sigma\sqrt{T}} + \frac{1}{2}\sigma\sqrt{T}$$

$$\text{und } d_2 = \frac{\ln\left(\frac{S_0}{X}\right) + rT}{\sigma\sqrt{T}} - \frac{1}{2}\sigma\sqrt{T} = d_1 - \sigma\sqrt{T}$$

Myron Samuel Scholes bekam für diese Formel 1997 den Nobelpreis für Wirtschaftswissenschaften. Er war danach der Manager vom Long Term Capital Management (LTCM) Hedgefonds mit 4,6 Mrd. US-Dollar. Bereits im September 1998 war der Hedge-Fonds pleite. Der Verlust löste damals eine große Krise an den Finanzmärkten aus.

Brandmaier's Lieblingswerkzeug:

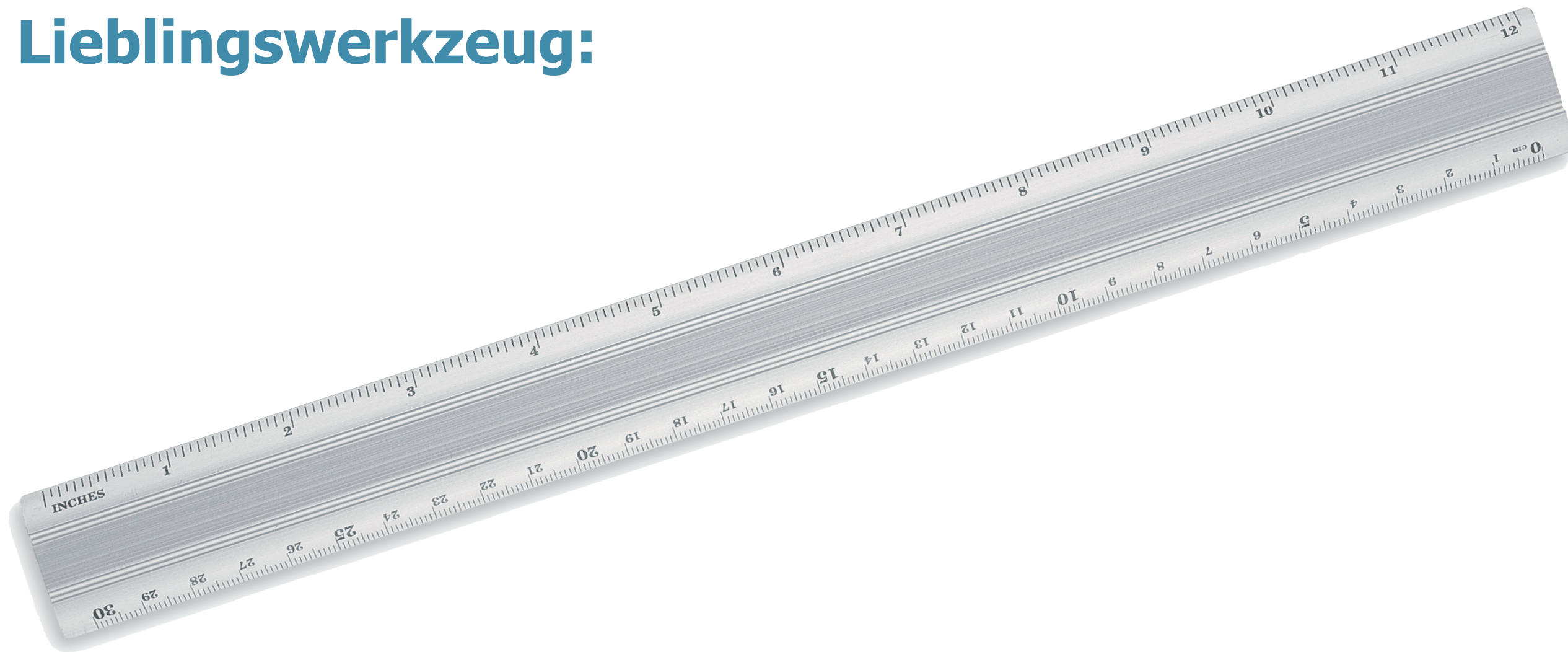

SINGULUS



300 % in 12 Monaten

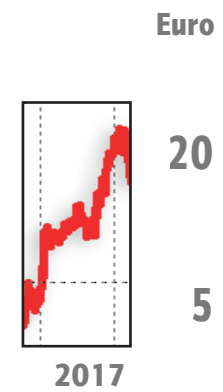

SINGULUS



SINGULUS



SINGULUS



Euro

Mercedes-Benz

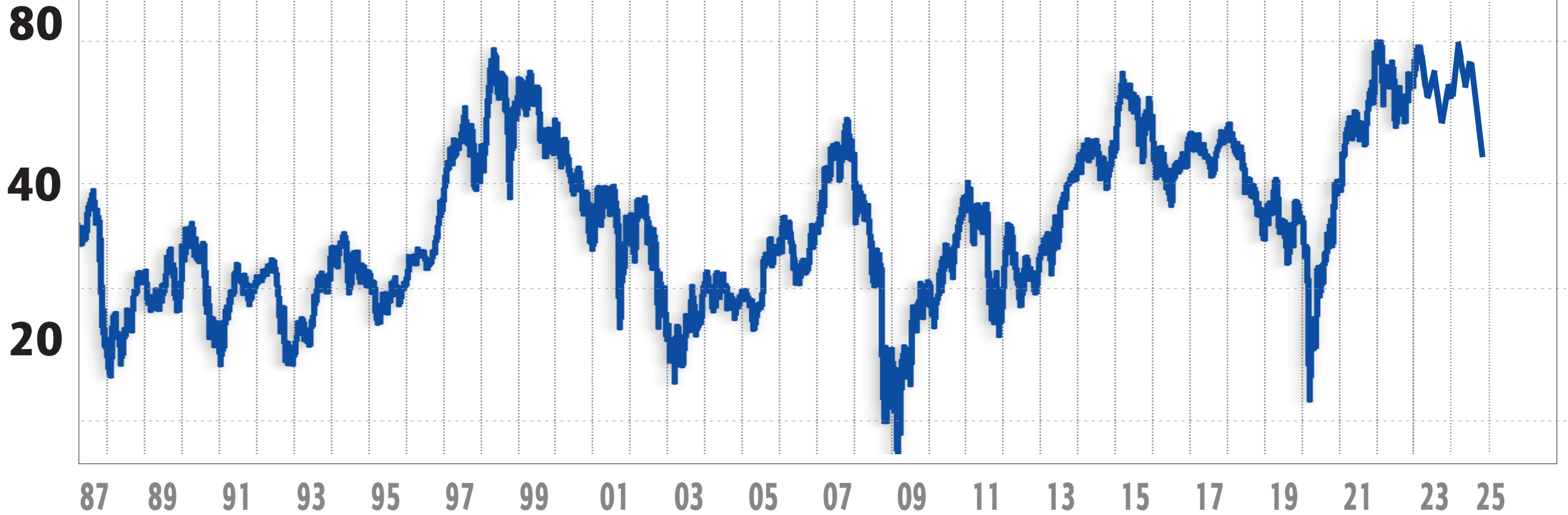

aktueller Kurs 53 Euro

Euro

Mercedes-Benz



aktueller Kurs 53 Euro

Euro

Mercedes-Benz



aktueller Kurs 53 Euro





Beiersdorf



aktueller Kurs 125 Euro



Beiersdorf

Mercedes-Benz

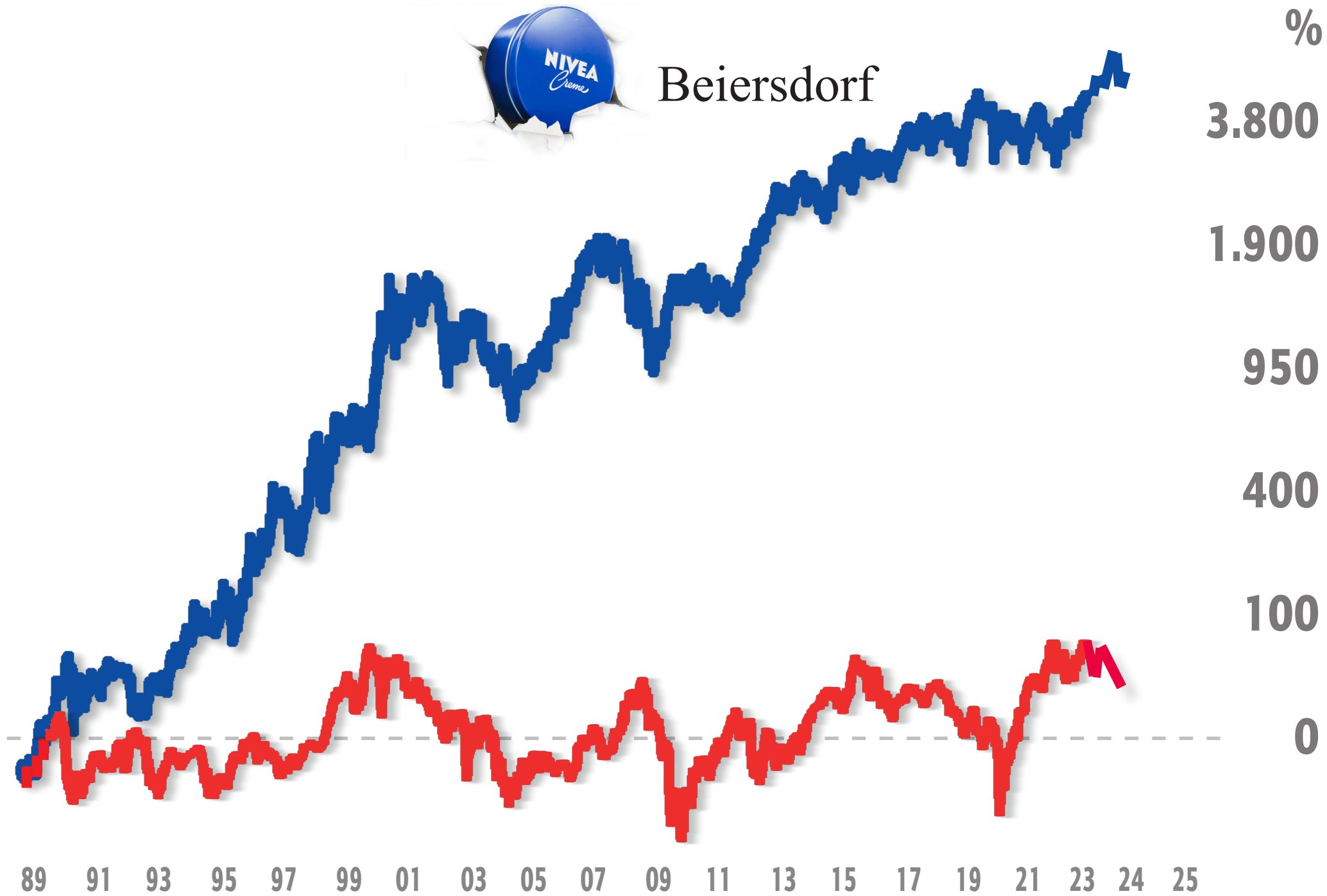

**Jedes Jahr Gewinn,
unabhängig von
der Konjunktur ...**

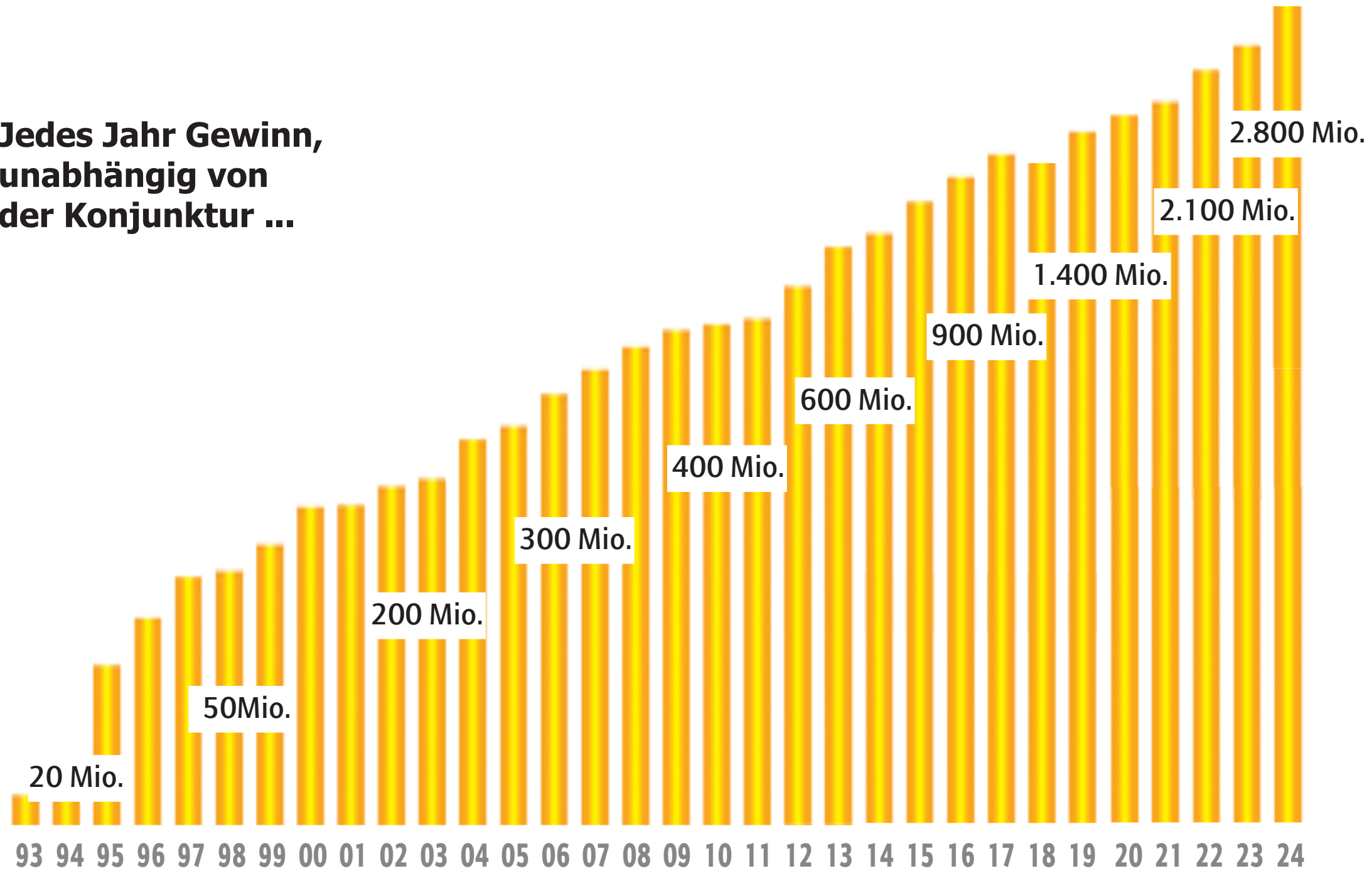

**Jedes Jahr Gewinn,
unabhängig von
der Konjunktur ...**

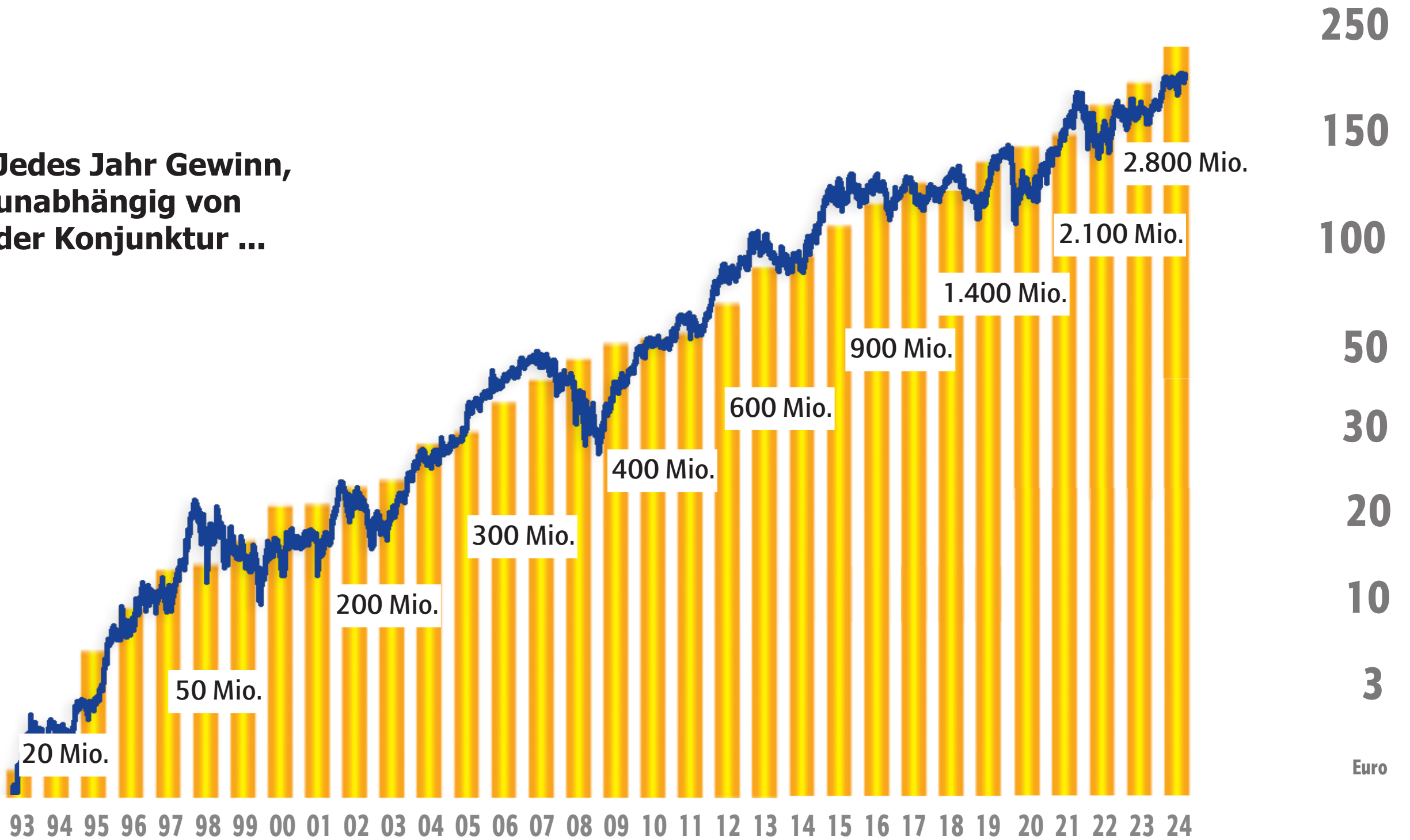

**Jedes Jahr Gewinn,
unabhängig von
der Konjunktur ...**

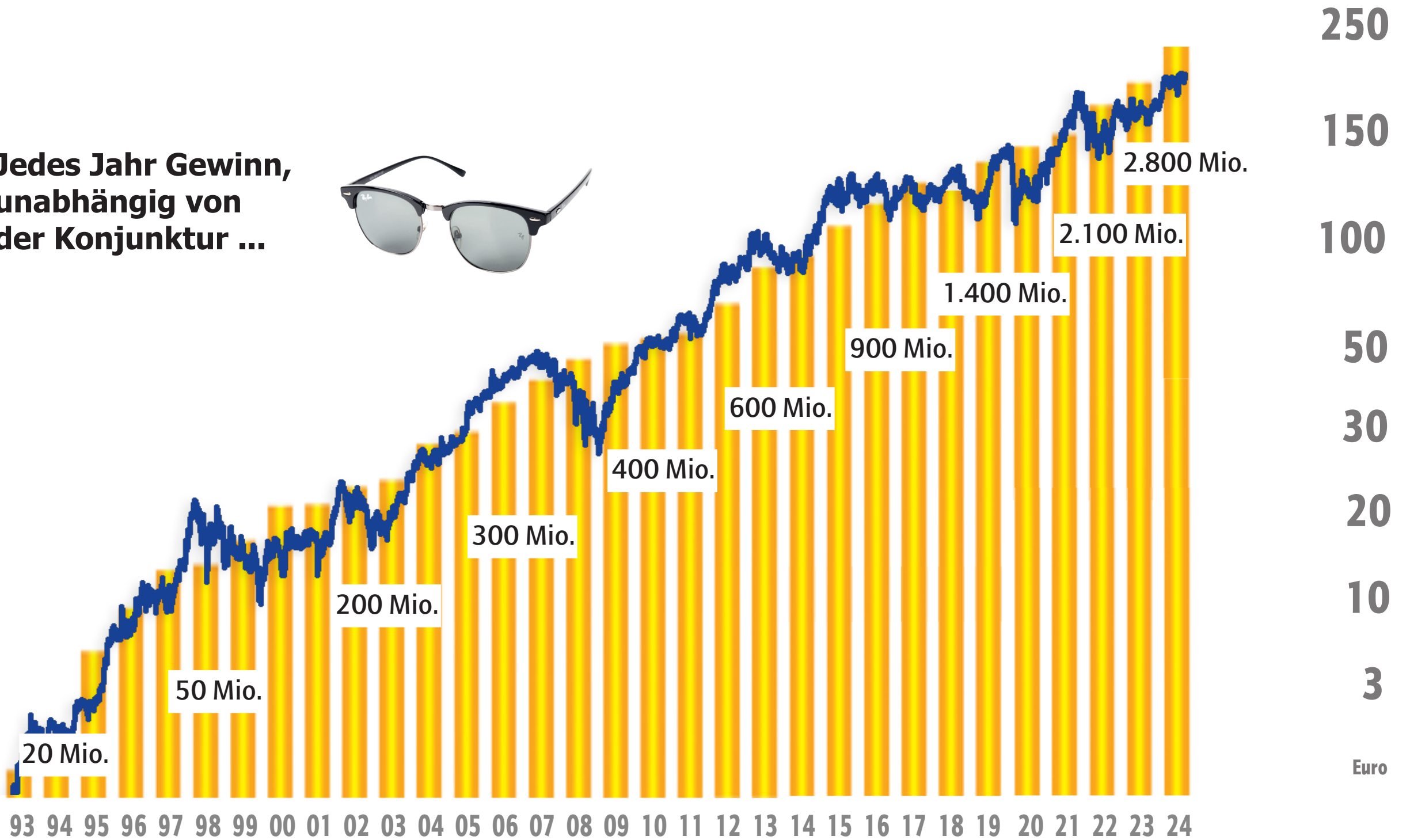

Euro

Essilor-Luxottica

Jedes Jahr Gewinn,
unabhängig von
der Konjunktur ...

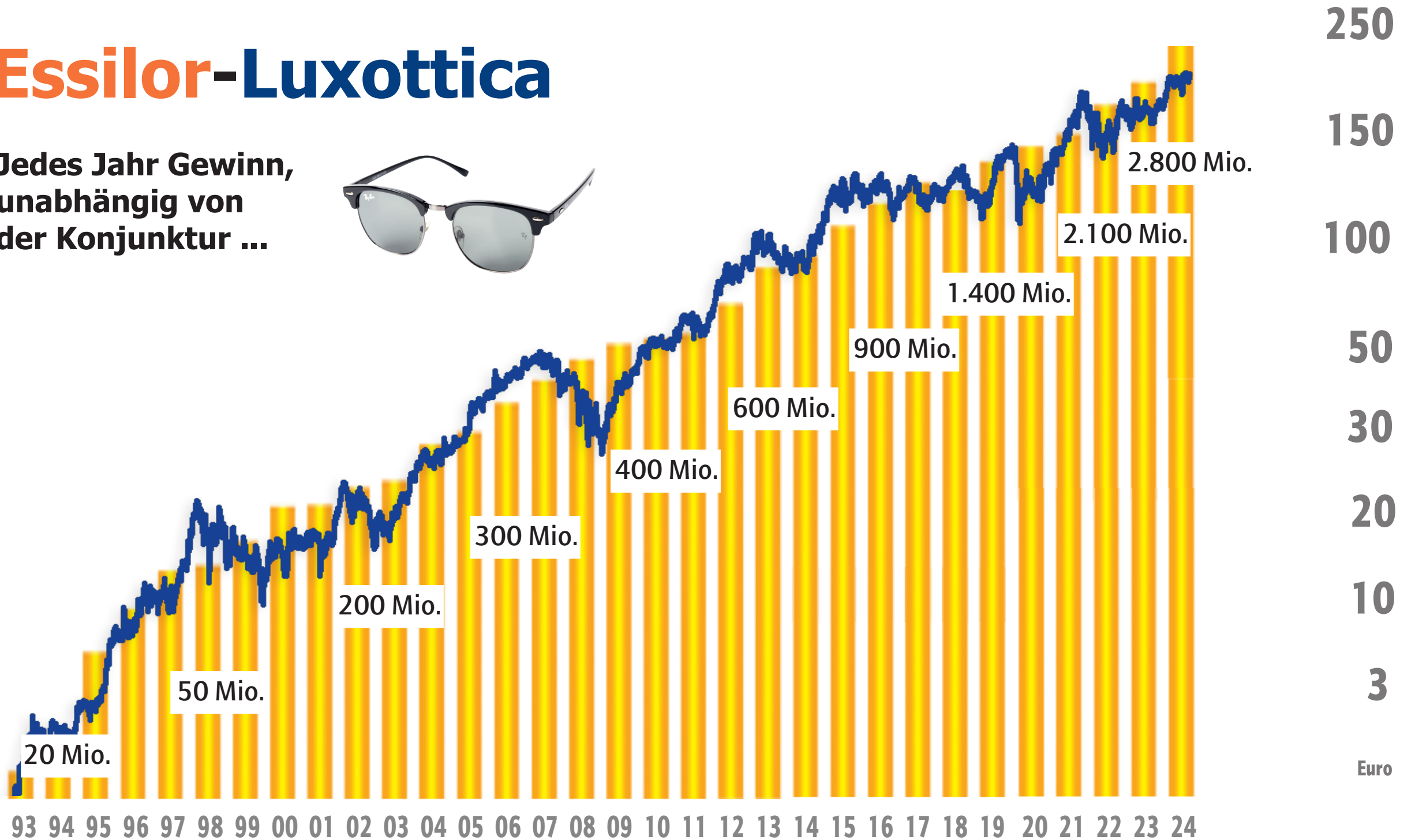

Essilor-Luxottica

Weltmarktführer
Brillengläser































Hauptzentrale in Mailand

VARILUX-
Gleitsichtglas
Für sofortige Sehschärfe
auch in Bewegung.



Essilor-Luxottica

 	 BURBERRY <i>London, England</i>	 BVLGARI
 CHANEL	  COACH NEW YORK	 DKNY
 DOLCE & GABBANA	 EMPORIO ARMANI	 GIORGIO ARMANI
 MICHAEL KORS	 MIU MIU EYEWEAR	  OAKLEY
 OLIVER PEOPLES OOVVOO	 <i>Paul Smith</i> SPECTACLES	 
 POLO RALPH LAUREN	 PRADA EYEWEAR	 RALPH LAUREN
 	 STARCK® EYES	 TIFFANY & CO.
 TORY BURCH	 VALENTINO	 VERSACE

Weltmarktführer
Brillengestelle

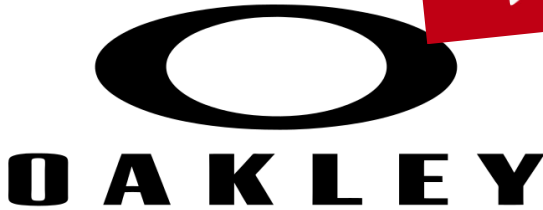

Essilor-Luxottica

Neu: Brille mit integriertem Hörgerät



Essilor-Luxottica

Jedes Jahr Gewinn,
unabhängig von
der Konjunktur ...

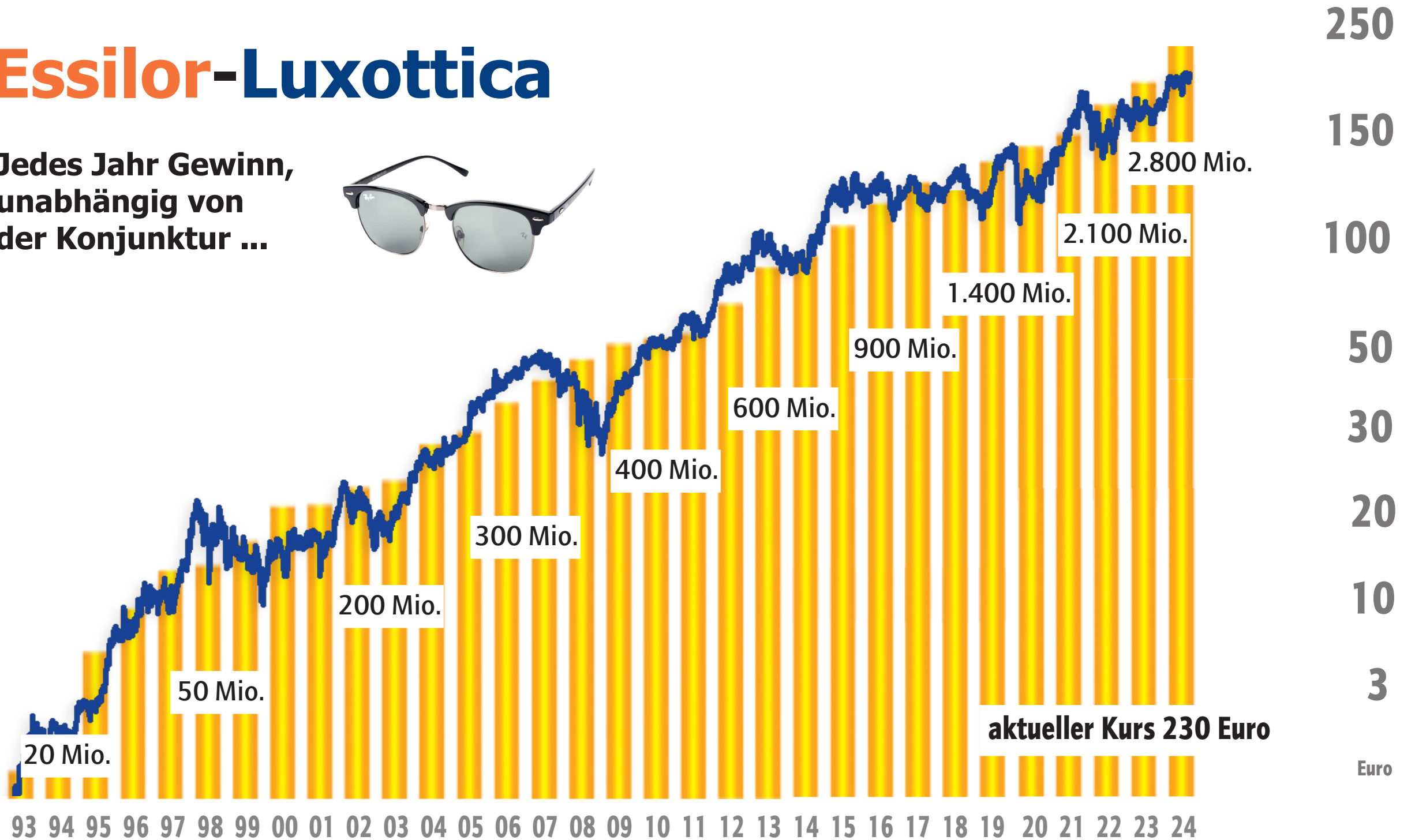

Essilor-Luxottica

Jedes Jahr Gewinn,
unabhängig von
der Konjunktur ...

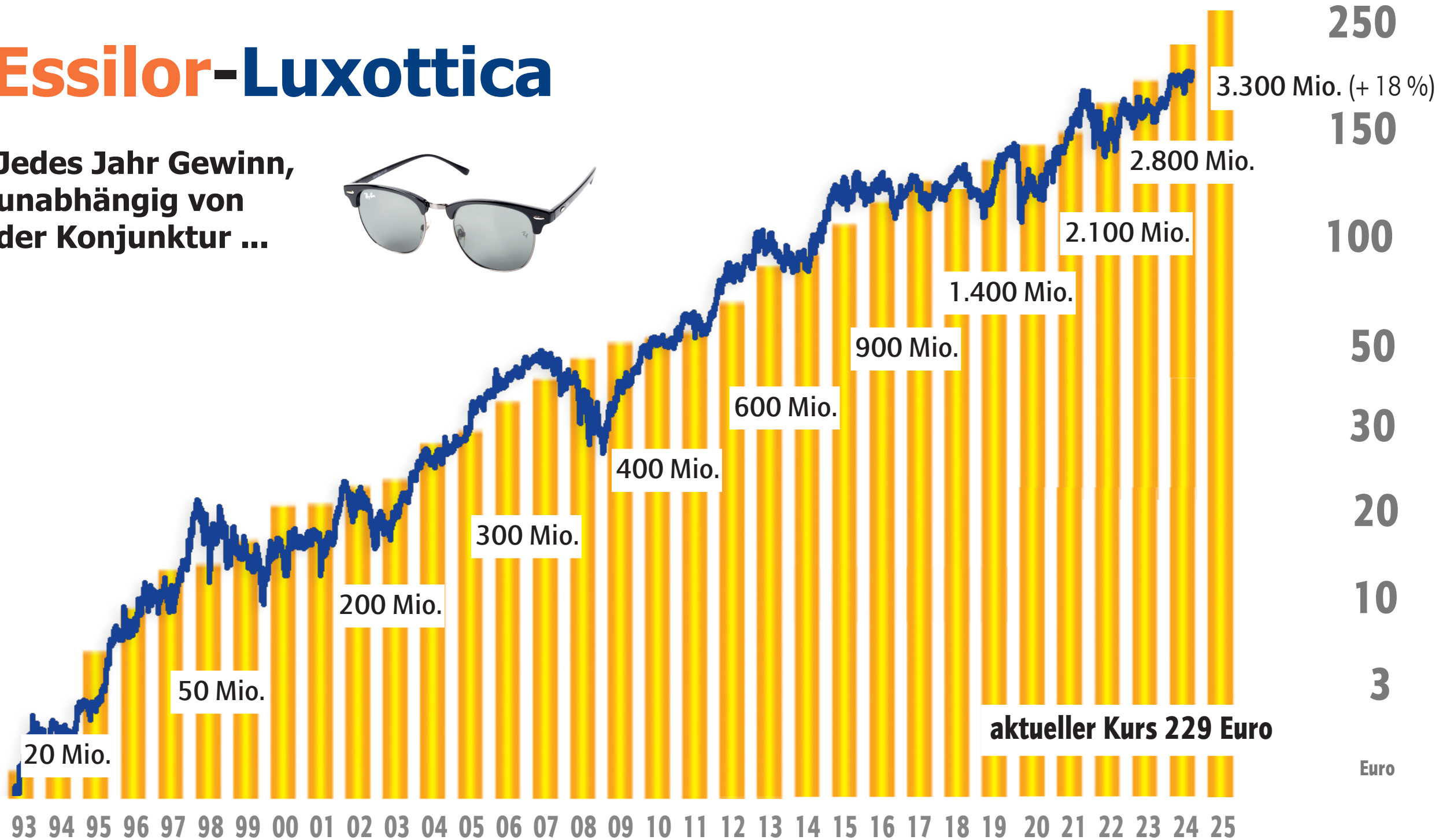

Hüftgelenke



Bandscheiben

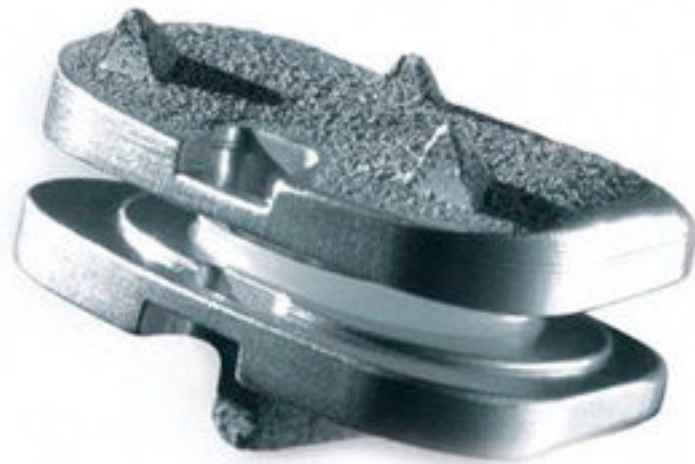

Ellenbogen



Kniegelenke

USD

stryker[®]

800

400

200

100

50

15

5

3

1

0,5

85

87

89

91

93

95

97

99

01

03

05

07

09

11

13

15

17

19

21

23

25

27



USD

stryker®

800

400

200

100

50

15

5

3

1

0,5

85

87

89

91

93

95

97

99

01

03

05

07

09

11

13

15

17

19

21

23

25

27

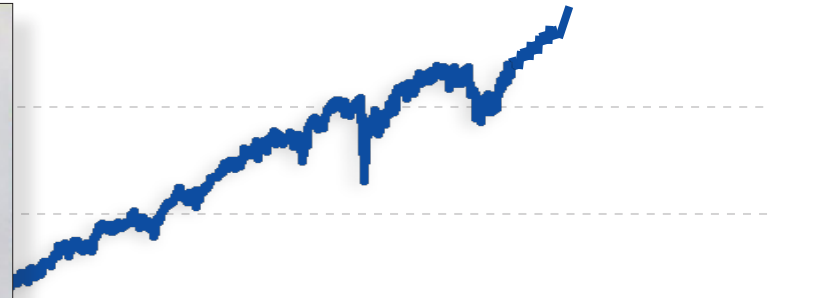





USD

stryker®

800

400

200

100

50

15

5

3

1

0,5

85

87

89

91

93

95

97

99

01

03

05

07

09

11

13

15

17

19

21

23

25

27



aktueller Kurs 390 USD / 370 Euro



2x  = JUMBO
PACK • PAQUET • PAK



*Optimal protection
- day & night!
Protection optimale de jour
comme de nuit*

Pampers
Baby-Dry

4+ MAXI PLUS
9-20 kg
20-44 lbs

2x40=80 



Procter & Gamble



Procter & Gamble



BRAUN





Procter & Gamble

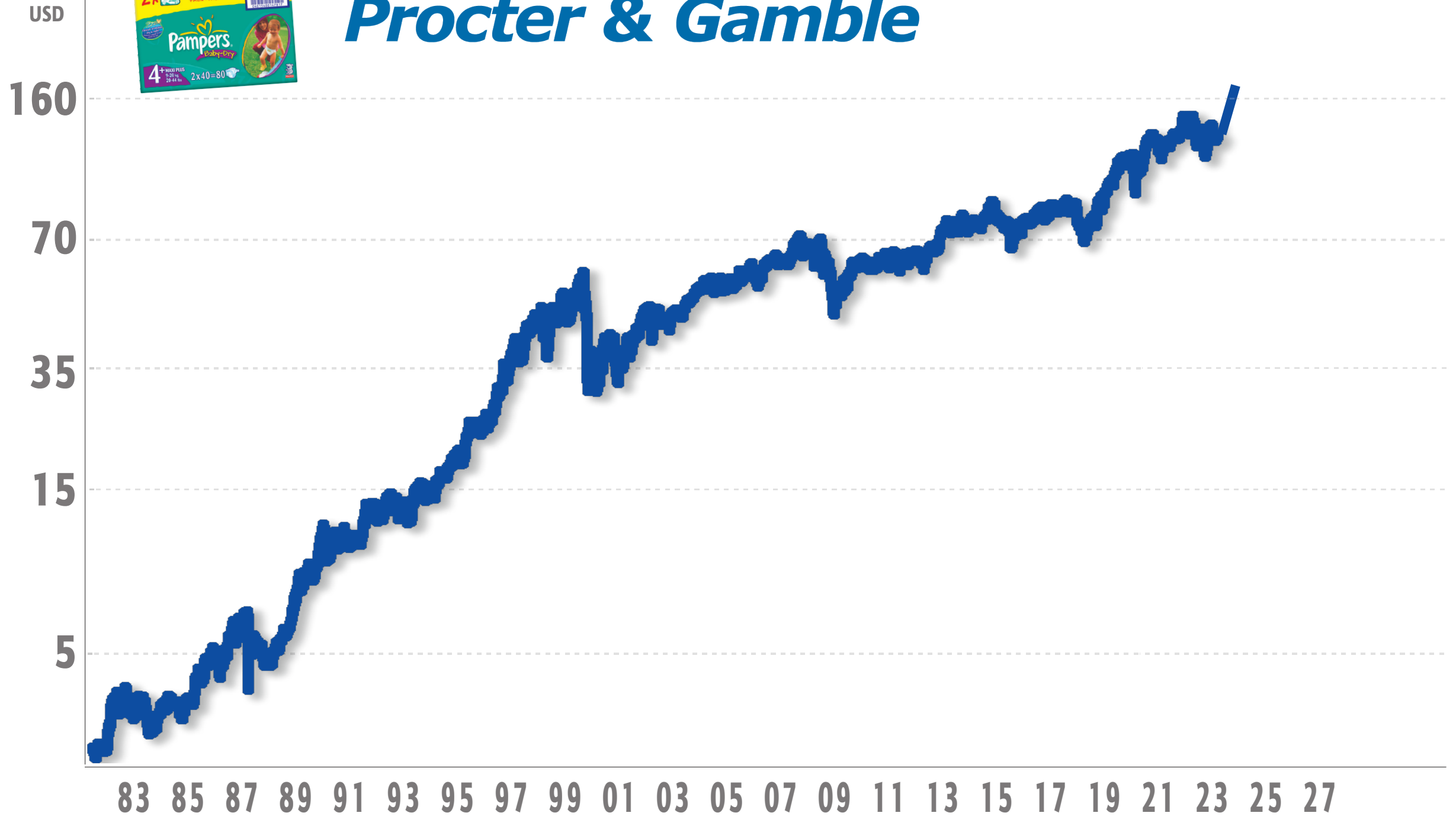



Procter & Gamble

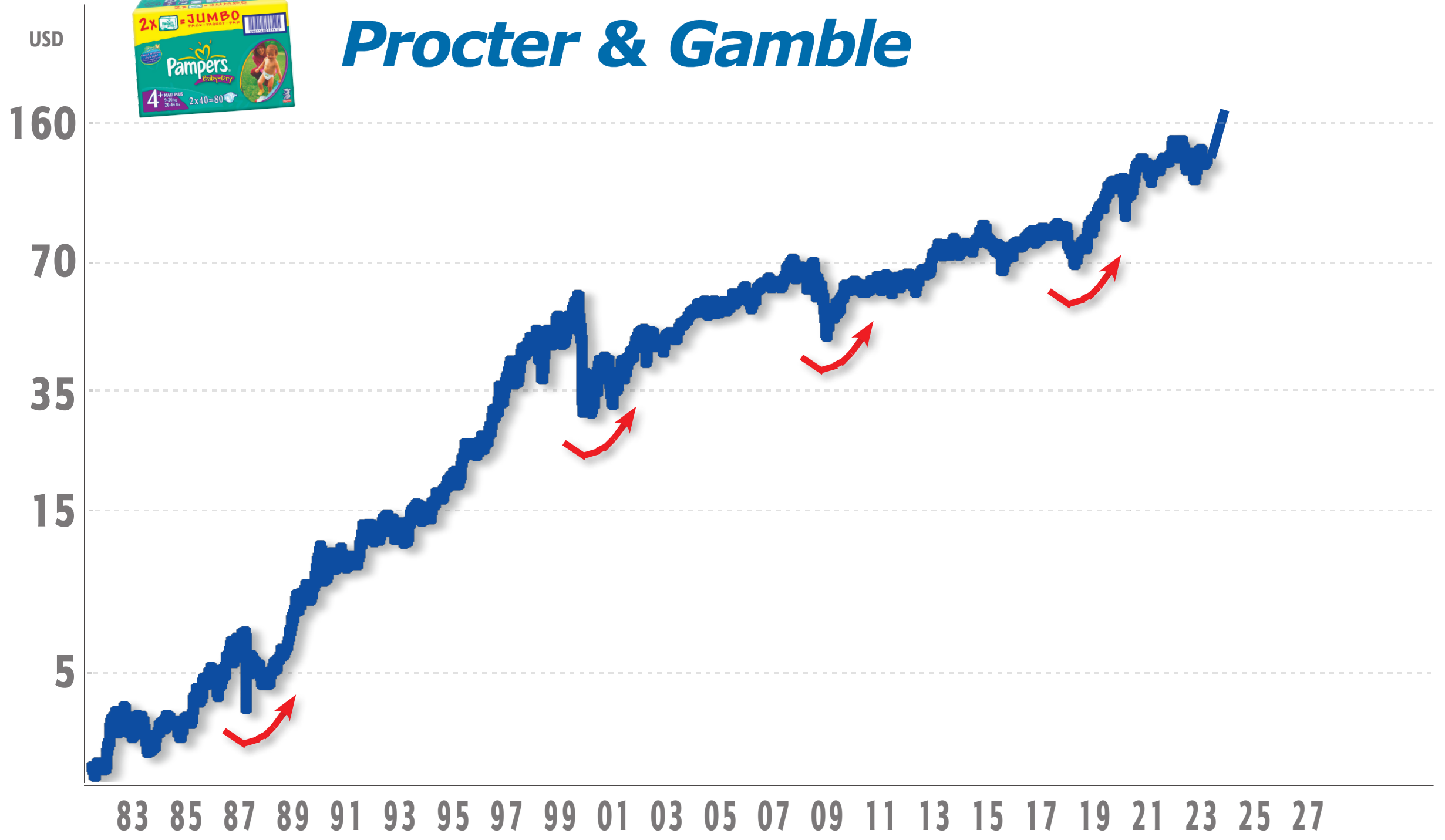

Maximilian Brandmaier, im Jahr 1998





Procter & Gamble

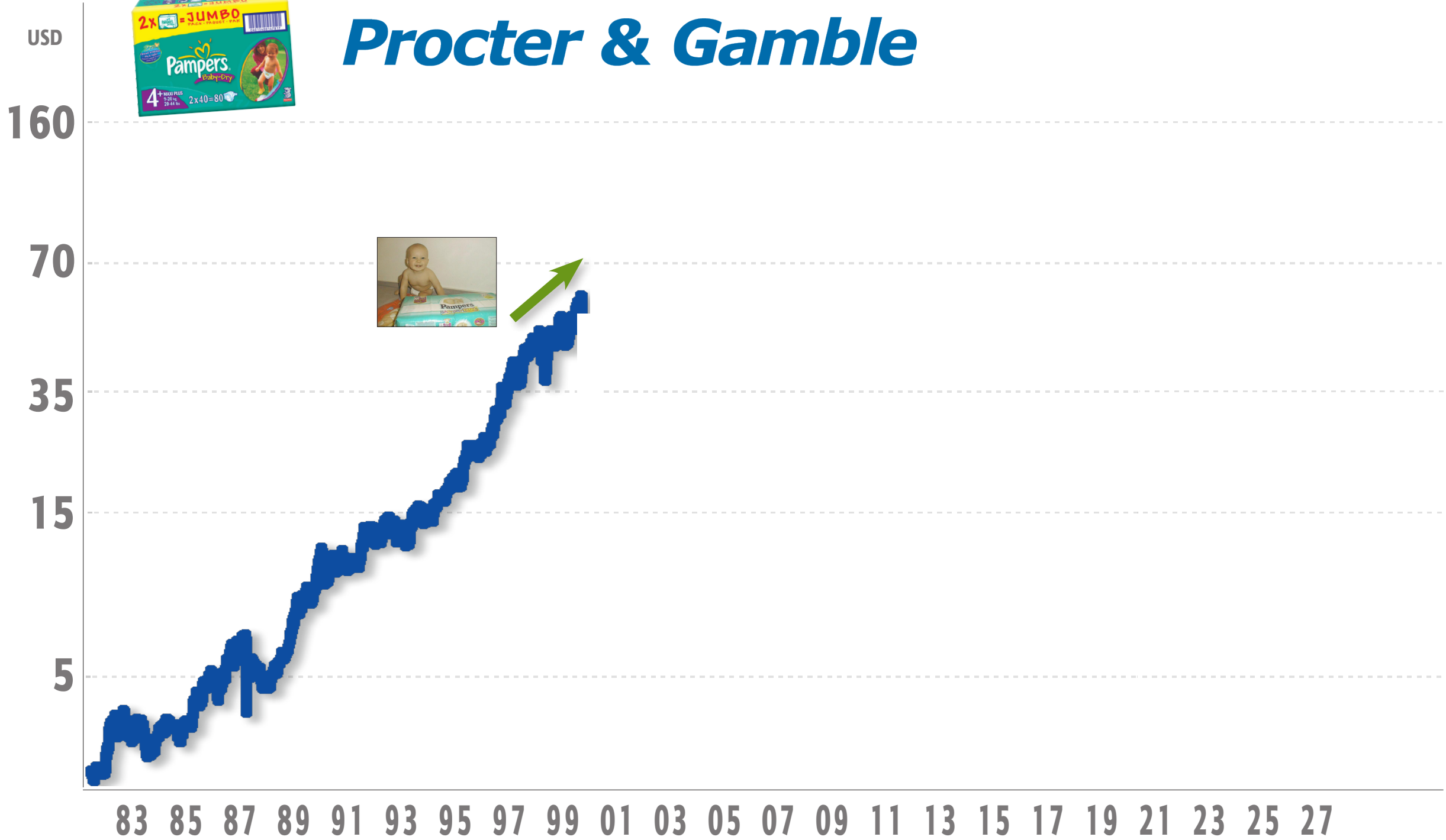



Procter & Gamble

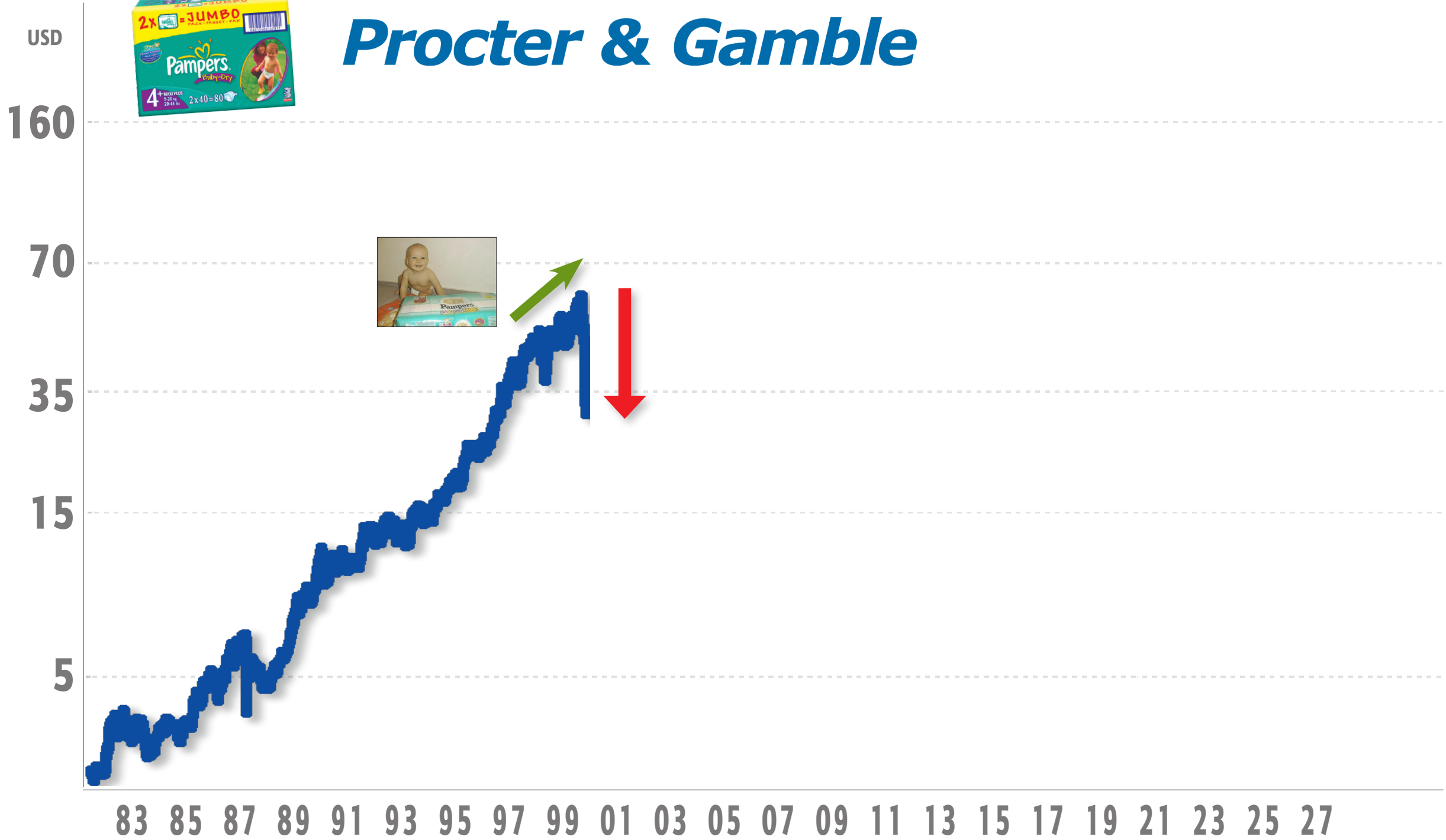

Maximilian & Janina Brandmaier im Jahr 2000





Procter & Gamble

USD

160

70

35

15

5

83 85 87 89 91 93 95 97 99 01 03 05 07 09 11 13 15 17 19 21 23 25 27

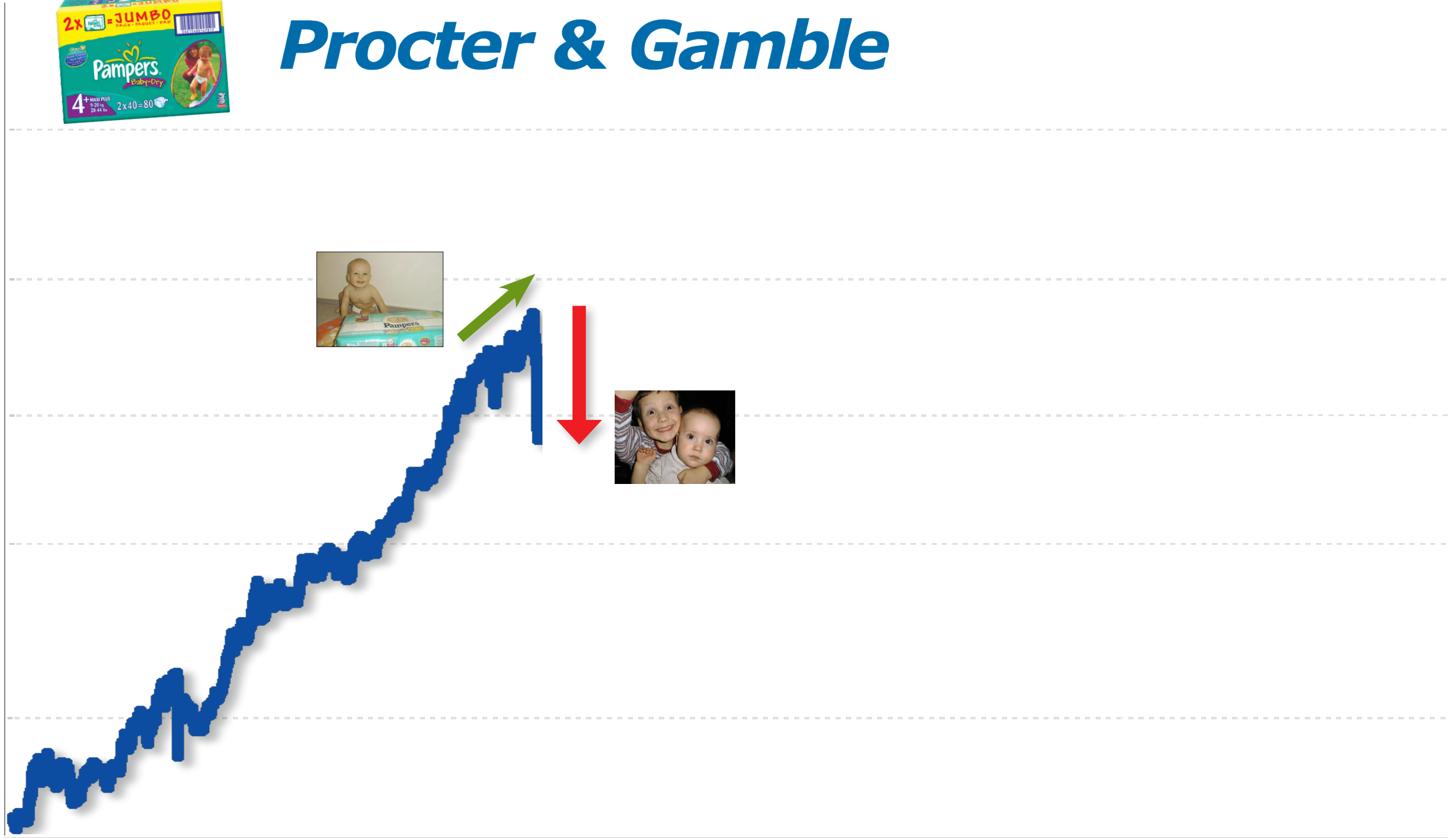



Procter & Gamble

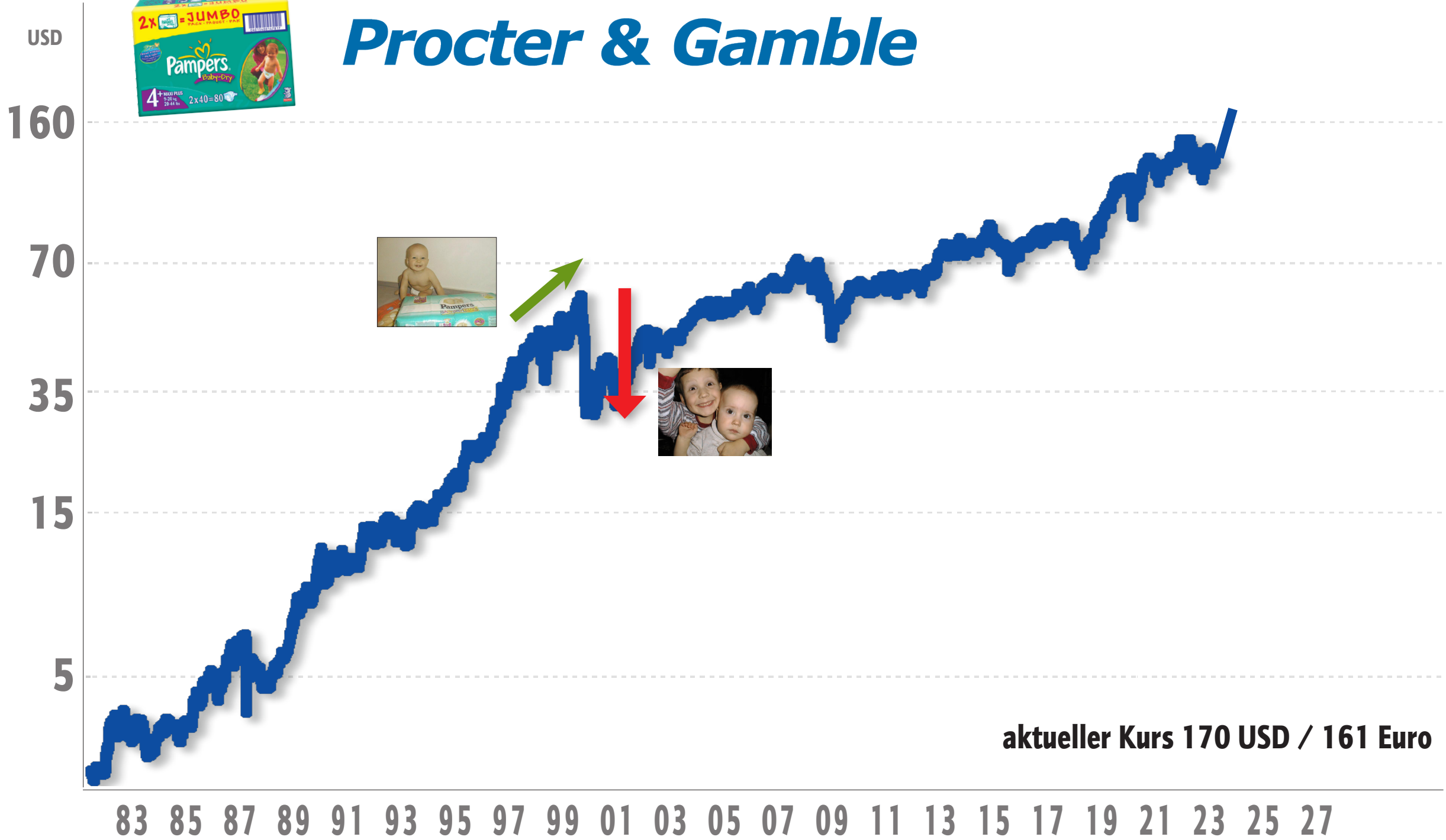

Wo essen 70 Millionen Menschen täglich?



Mc Donald's

Entwicklung der weltweiten Anzahl von McDonald's-Restaurants von 2000 bis 2023



2027: Über 50.000 Restaurants

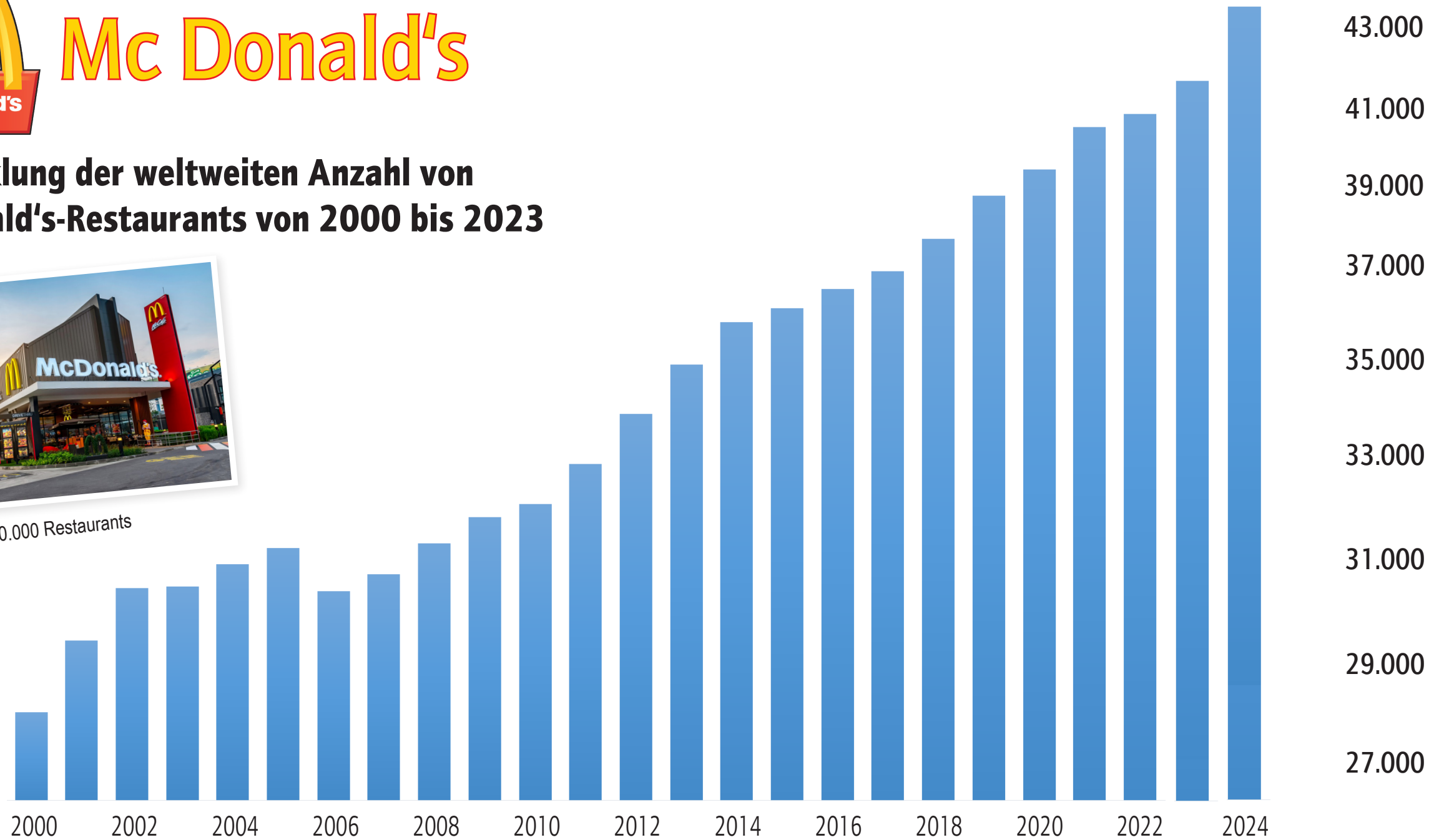

**Das größte McDonalds:
10.000 qm Fläche – 700 Sitzplätze**



**Peking
China**

**Das kleinste McDonalds:
9 qm Fläche – 0 Sitzplätze**

Shanghai



**McBoat in Hamburg:
Anlegen und bestellen!**

Paddel-Through



USD



Mc Donald's

400

200

100

50

25

10

5

84 86 88 90 92 94 96 98 00 02 04 06 08 10 12 14 16 18 20 22 24 26 28

aktueller Kurs 292 USD / 278 Euro

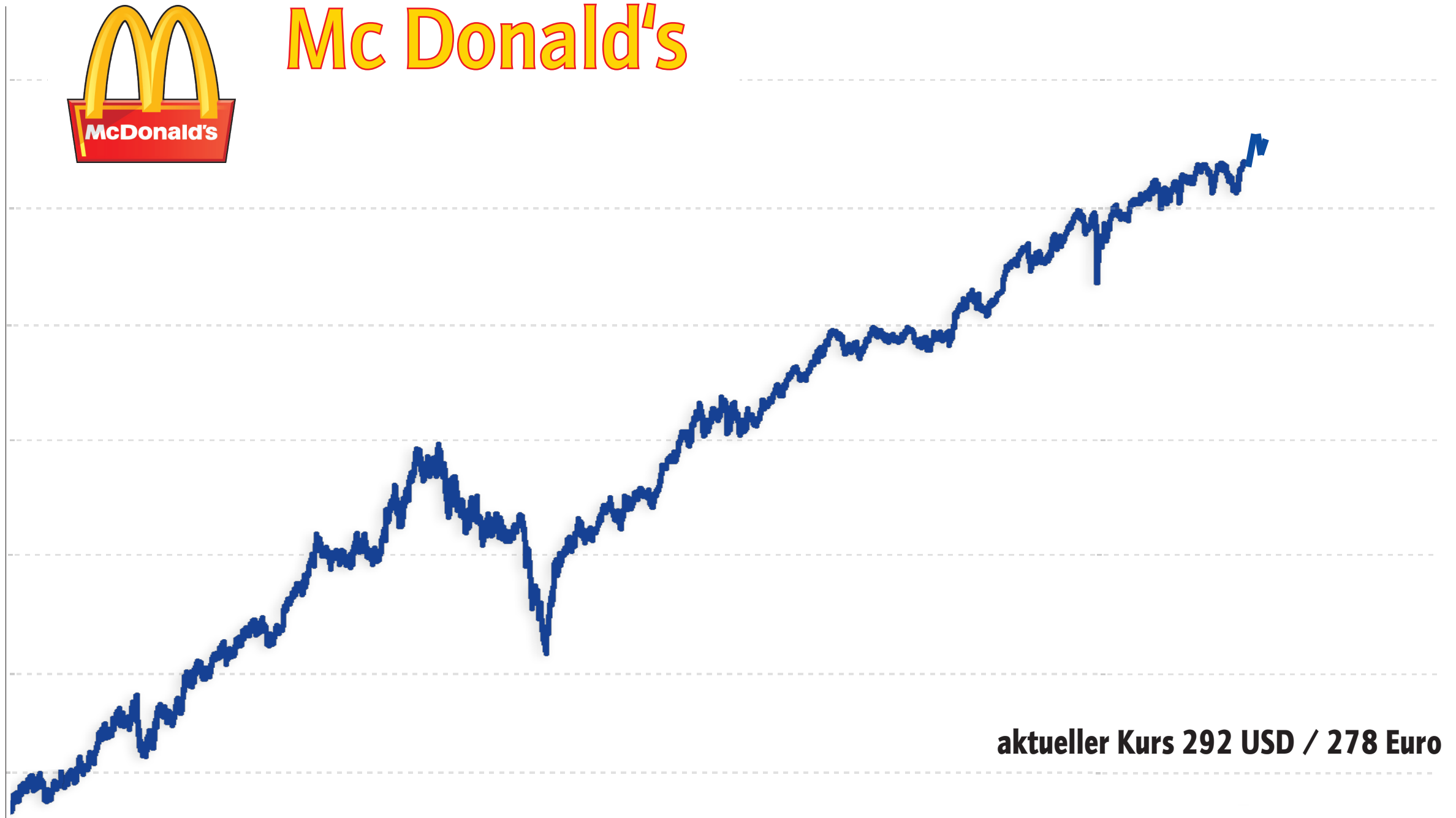



USD



800

500

200

100

50

25

10

07

08

09

10

11

12

13

14

15

16

17

18

19

20

21

22

23

24

25

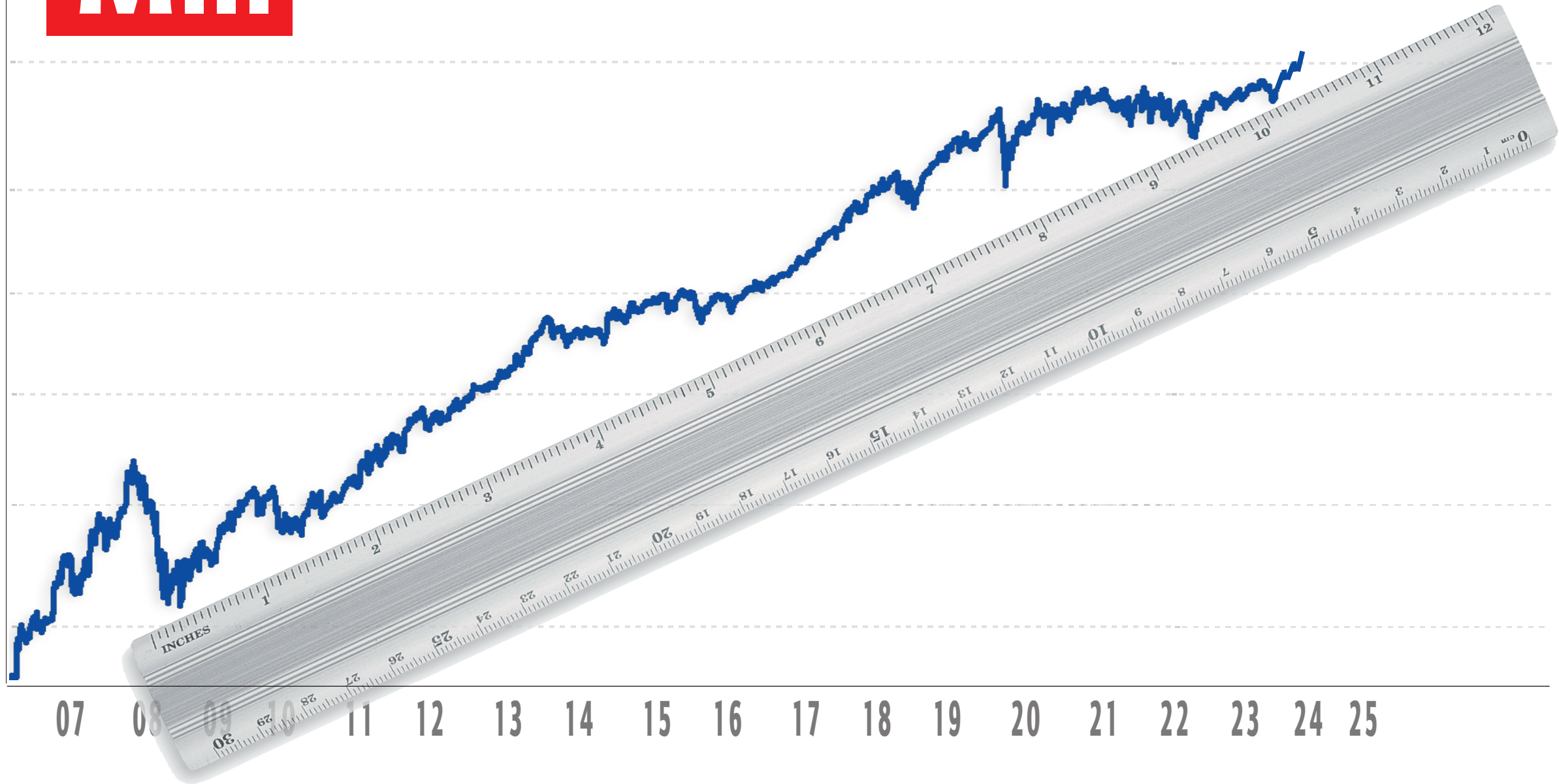



aktueller Kurs 522 USD / 495 Euro

Jetzt für Sie im Foyer

- Für alle Besucher heute kostenlos:
Brandmaier´s Börsenbuch
„Alles über Aktien“ – auf
Wunsch auch handsigniert!

- Das Börse Aktuell-Team steht
Ihnen jetzt im Foyer für alle
Ihre Fragen zur Verfügung.

Vielen Dank für Ihren Besuch!

**Mein
Börsenbuch**

